

ELITE SERIES

# Automated Consolidation



# ELITE SERIES Automated Consolidation

## ConMatic IPC, Automated Consolidation System

ASTM: D2435, AASHTO: T216, BS: 1377:5

The HM-5470.3F ConMatic IPC is a fully-automated, incremental pressure controller for performing incremental consolidation tests.

The ConMatic IPC allows consolidation, constant load tests to be run automatically, freeing up technicians for other tasks and reducing the duration of the testing procedures by more than half—effectively saving time and manpower and increasing lab profitability. One ConMatic IPC automated system can replace the production of several manual machines—running incremental consolidation tests according to ASTM D2435 Method B, where successive load increments are applied after 100% primary consolidation.

Once a sample has been placed onto the test platform and the test conditions set, the ConMatic IPC performs all consolidation tests, including moving to the next stress level, without operator

assistance. The system automatically moves through the different test parameters specified by the user with incremental consolidation tests typically being completed in 24 to 48 hours. The Humboldt NEXT software with the HM-5100SW Consolidation module uses sample deformation readings taken from the displacement transducer and load readings from the load cell to maintain a constant applied stress or strain to the sample through the use of a digital pressure regulator. Test results are recorded and rendered in real-time on the computer screen while test data is stored and calculations are performed automatically. Humboldt's NEXT software with the HM-5100SW Consolidation module provides:

- Live test data tabulation and live graphing capabilities (real-time)
- Complete test reporting including all calculations and graphs required for testing
- Review and exporting of tests using Microsoft Excel
- Smart Test Function: automatically picks up where it left off if the test was not finished due to unexpected events within your computer

The unique design of the ConMatic IPC system enables the user to connect multiple ConMatic IPC units to a single computer and run them independently and simultaneously when connected via a LAN-network.



### NOTES

Includes Humboldt NEXT Software HM-5100SW Consolidation-Specific Module



HM-5470.3F



### Controller Specifications:

Display (Resistive Touch)	7" (178mm) VGA (480 x 800)
Real-time test data	Graphic and tabulation
Processor	Dual 32-bit ARM
RAM	64MB
Memory, non-volatile	4GB
Analog to digital converter	24 bit
Data acquisition	2 Channels
Logging Rate	effective rate of 320 readings per second
Multi-test storage	1000
Points per test	3000
USB port (front)	export data, import/export calibration data
USB port (back)	provides external power for wireless access point
Ethernet connection	for network connectivity
24-bit differential analog to digital converter	2
Ambient temperature sensor	1
Firmware Update	Ethernet or flash drive





## UPGRADE

Convert your existing Humboldt HM-2470.3F to the new HM-5470.3F, order HM-5470U.



HM-5470.3F

Specifications:	
Sample size	up to 4" (100mm)
Maximum load	2200lbf (10kN)
Clearance, vertical	8.25" (210mm)
Clearance, horizontal	7.75" (197mm)
Maximum piston travel	0.5" (12.7mm)
Dimensions (L x W x H)	12" x 12" x 30" (305 x 305 x 762mm)
ConMatic IPC System Requirements	
AC Supply	110/220 VAC 50/60Hz 5 Amp
Air Supply	Clean and dry (air filter, water trap), min.: 100psig (689kpa) max.: 300psig (2068kpa) continuous air supply 4.2CFM (0.12m <sup>3</sup> /min)*

\* Larger compressor may be required if used with additional equipment or larger-sized labs.

### Computer Control

NEXT software and the enhanced Consolidation module, HM-5100SW, is included with the ConMatic IPC automated consolidation machine. This software provides robust machine control, calibration, data acquisition and report generation for those using a computer to control consolidation testing operations.

In addition, operators have the ability to view and control testing operations from a PC in the lab, in the next room or at a different location,

while also providing report generating capabilities using the consolidation test-specific software module. So, whether you are controlling a single consolidation machine, controlling multiple machines, or even a complete geotechnical lab, Humboldt's NEXT software, in conjunction with Humboldt's ConMatic IPC, provides a complete solution for the acquisition, recording and presentation of consolidation testing data in data tabulation and graphic chart formats.

- Machine control, and data acquisition via networked computer
- Provides the ability to use Humboldt's Next Software's, advanced test-specific modules
- Real-time graphical chart and numerical display of tests via computer display
- Effective sampling rate of 320 readings per second
- Stores 1000 tests with up to 3000 points per test.
- Up to 255 individual tests can be run simultaneously from a single PC
- Provides advanced graphing capabilities
- Provides full-unit customization
- Reports can also be exported to Excel or a CSV file, if desired, and, we can provide custom integration/export solutions for LIMS, EQUIS, gINT, etc.

ConMatic IPC, 120/220V 50/60Hz **HM-5470.3F**



Shipping wt. 52 lbs (23.85kg)

### The HM-5470.3F ConMatic IPC Includes:

(1) Pancake load cell 2,000 lbs (10kN) with 0.75" adapter	HM-2300.020CP
(1) Linear strain transducer, 1.0" (25mm)	HM-2310.10
Controller Filter Kit	HM-200926
(1) NEXT consolidation software module	HM-5100SW

### Typical HM-5470.3F Consolidation Setup:

Description	Part #
ConMatic IPC	HM-5470.3F
Required Components, Order Separately	
Fixed ring consolidation cell	HM-1220.XX*

\* XX Requires a sample size designation, see page 122-123 for choices

### Additional Items Required

PC computer	not supplied
Refrigeration Dryer	HM-4221
Desiccant Dryer, Silica Gel	HM-4222
Filter/Regulator	HM-4223
Consolidation Installation Kit	HM-4168
25' of 0.25" Tubing	HM-4196.25 (sold by the foot)
Controller Filter Kit replacement	HM-200926

# Pneumatic Consolidation

## ConMatic Pneumatic Consolidation Machine

ASTM: D2435, D4546, D5333; AASHTO: T216, BS:1377:5

Compact and easy-to-use, the HM-5432.3F pneumatic consolidation load frame is used to estimate the rate and amount of settlement anticipated for a proposed structure. The unit applies loads instantly without impact for stress-controlled consolidation testing; and, maintains the load regardless of sample compression. Its small footprint saves valuable lab counter space while maintaining its versatility by supporting fixed ring, floating ring, or permeability cells.

### Features Include:

- Highly-sensitive accuracy in lower load ranges
- Integral digital readout simplifies checking applied load and setup of predetermined load
- Adjustable upper cross beam
- Instantaneous loading without impact
- Flexible load choice
- Not sensitive to shock
- Choice of English or Metric models

The HM-5432's digital readout displays applied loads with the help of precision pressure regulators and pressure transducers with a linearity of  $\pm 0.1\%$ . The 1" (25.4mm) thick aluminum platforms have centering pads and accept any consolidation ring up to 4.0" (100.0mm) in diameter. Stainless steel vertical rods support the cross-head and dial gauge. One HM-001076- Pressure Ball is included with the unit. Air supply tubing (25') to hook up the compressed air line is also included. The unit features a durable enamel, powder-coated steel cabinet which protects the internal components.

Specifications:	
Sample size	up to 4" (100mm)
Maximum load	2200lbf (10kN)
Clearance, vertical	8.25" (210mm)
Clearance, horizontal	7.75" (197mm)
Maximum piston travel	0.5" (12.7mm)
Dimensions (L x W x H)	12" x 12" x 30" (305 x 305 x 762mm)
ConMatic System Requirements	
AC Supply	110/220 VAC 50/60 Hz 5 Amp
Air Supply	Clean and dry (air filter, water trap), minimum: 100psi (700kps) continuous air supply 4.2CFM (0.12m <sup>3</sup> /min)*

\* Larger compressor may be required if used with additional equipment or larger-sized labs.



HM-5432.3F



### UPGRADE

Convert your Humboldt HM-2432A.3F to the NEW HM-5432.3F, order HM-5432U.

The HM-5432 can be used with a standard mechanical dial gauge setup or, for data acquisition applications, it can be teamed with digital indicators or strain transducers (LSCT) and coupled to one of the Humboldt's data loggers. For additional data acquisition capabilities add Humboldt's NEXT HM-5100SW Consolidation-specific module and a computer for enhanced data acquisition and report capabilities. **The HM-5432.3F only includes the basic unit, order gauges and cells separately.**

ConMatic TSF, 120/220V 50/60Hz HM-5432.3F

ConMatic kgf/cm<sup>2</sup>, 120/220V 50/60Hz HM-5432M.3F

Shipping wt. 48 lbs (21.7kg)

### Typical HM-5432.3F Consolidation Setup:

Description	Part #
ConMatic 32 TSF	HM-5432.3F
ConMatic 32 Kgf/cm <sup>2</sup>	HM-5432M.3F
Required Components, Order Separately	
Fixed ring consolidation cell	HM-1220.XX
Dial gauge, 0.5" X .0001" CC	H-4471CC
Dial gauge, 12 X 0.002mm CC	H-4465.12CC

\* XX Requires a sample size designation, see page 122-123 for choices

# Dead-Weight Consolidation

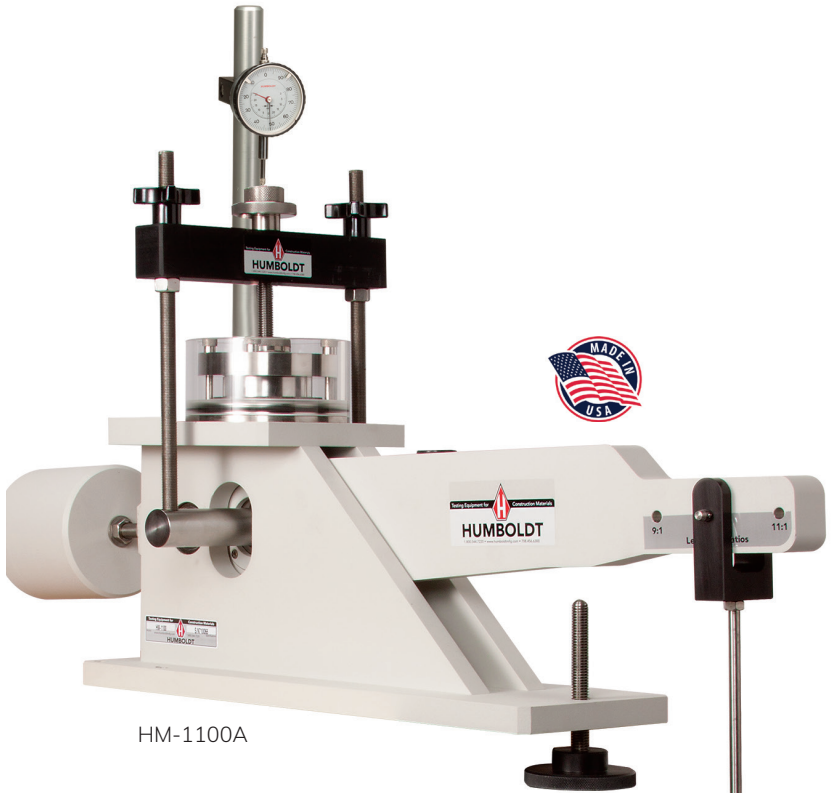

HM-1100A

## Dead-Weight Consolidation Frame

ASTM: D2435, D4546, AASHTO: T216, BS:1377:5

Able to survive in even the harshest laboratory environments, the HM-1100A will provide you with reliable service day-in and day-out. The design features a rugged frame manufactured from aluminum with stainless steel vertical rods, horizontal cross arms and beam support rods. The load arm incorporates 9:1, 10:1, and 11:1 beam ratios for greater flexibility and loading weight requirements. Using the 10:1 ratio on 2.5" (63 mm) diameter samples, the system is capable of producing loads up to 48 tsf (4,597 kPa).

- Triple beam ratios minimize loading weight requirements
- 48 tsf (5,148 kPa) maximum load capacity
- Aluminum and stainless steel construction for corrosion resistance and long life
- Wide range of consolidation cells available in fixed ring, floating ring, permeability and back-pressure designs
- Loading weights available in both, tsf and kg versions
- Basic unit does not include a dial indicator, order separately, see page 152.
- The HM-1100A can also be paired with our Data Loggers with digital indicators or strain transducers (LSCT). See next page.

Dead-Weight Consolidation Frame HM-1100A

Shipping wt. 75 lb (34kg)

Specifications	
Load Capacity	48 tsf (4,597 kPa)
Beam Ratios	9:1, 10:1 and 11:1
Frame Construction	Heavy-duty aluminum frame with stainless steel vertical, horizontal and beam support rods
Cell Platform	Anodized aluminum with locating pins for centering cells.
Dimension (W x D x H)	7.75" x 32" x 19.5" (197 x 812 x 495 mm)
Weight	47 lbs. (21kg)

## Consolidation (Dead-Weight) Typical Setups:

Description	Part #
Dead weight consolidation	
Dead weight consolidation frame-front load	HM-1100A
Weight set, 16 TSF or Weight set, 64kg	HM-1120 † or HM-1123 †
Fixed ring consolidation cell	HM-1220.XX*
Dial gauge, 0.5" X .0001" CC or (12 x 0.002mm) CC	H-4471CC or H-4465.12CC

† More weight choices can be found on page 123.

\* XX Requires a sample size designation, see page 122-123 for choices



HM-1100.1

HM-1100.3

## Consolidation Frame Stands

Butcher block table-top with heavy-duty, steel frame designed to provide stable mounting platform for HM-1100A consolidation frames. Consolidation frames can also be bolted to the table and the table can be bolted to floor for increased stability.

Single-Station Frame Stand HM-1100.1

Triple-Station Frame Stand HM-1100.3

Shipping wt. HM-1100.1: 50 lb (23kg),  
HM-1100.3: 115 lb (52.1kg)



# DATA ACQUISITION SETUPS

## FOR SEMI-AUTOMATIC AND DEAD-WEIGHT CONSOLIDATION

Data Acquisition and Control for both the HM-5432 semi-automatic consolidation machine and the HM-1100A dead-weight consolidation frame can be achieved with the use of one of Humboldt's 4-channel data loggers. The touch-screen monitor of the data logger provides test control and live test monitoring in either a stand-alone or computer-controlled configuration.

In the case of the HM-5432, pneumatic loads are controlled by manual valve controls located on the front panel of the consolidation machine. With the HM-1100A dead-weight loads are controlled by physically adding weights to the consolidation frame. With both machines, the data logger provides four (4) integral and independent data acquisition channels, which can be utilized in stand-alone configurations or accessed through a LAN-networked computer using Humboldt's NEXT Basic software.

### Stand-Alone Test Monitoring

The touch-screen controller provides you with full, graphical monitoring of testing functions in a stand-alone application. The seven-inch, waterproof screen on the Humboldt Data Loggers provides at-a-glance monitoring of testing functions, in a real-time graphical display, without the use of a computer, building upon Humboldt's dedication to modular, stand-alone data acquisition.

Now, in a stand-alone application, you will be able to run tests and display results while viewing tabulation, basic x-y graphs and instrument readings in real-time during the test, using user-defined, basic data acquisition. Test data is stored in the device and can be downloaded to a USB drive via the machine's FRONT USB port or the data can be transferred to a computer via the LAN port.

- 4-channel data acquisition
- Hi-res, 7", waterproof, touch-screen provides total control and real-time graphical display of tests
- Machine/Test control and data acquisition via touch-screen

### Computer Test Monitoring

Humboldt's NEXT Basic software can be downloaded from: <https://www.humboldtmg.com/support/software.php> for use with a Humboldt data logger and computer. This software provides basic data acquisition and report generation for those using a computer for this purpose.

In addition, you can purchase Humboldt's HM-5100SW Consolidation module for consolidation test-specific set up and monitoring of the testing function.

- Data acquisition via a networked computer
- Provides the ability to use Humboldt's NEXT Software's HM-5100SW consolidation module
- Real-time graphical chart and numerical display of tests via computer display
- Effective sampling rate of 50 readings/sec.
- Stores 1000 tests with up to 3000 points per test.

### ConMatic Semi-Automatic Consolidation Machine



### Humboldt Dead-weight Consolidation Frame



#### Analog Data Acquisition Setup

Data acquisition setup for Pneumatic consolidation using analog transducer and Logger

ConMatic 32 TSF or ConMatic 32 Kgf/cm <sup>2</sup>	HM-5432.3F or HM-5432M.3F
Fixed ring consolidation cell	HM-1220.XX*
Strain transducer 0.4" (10mm)	HM-2310.04
Strain transducer bracket	HM-2310BR
Humboldt Logger 4 channel analog data acquisition	HM-5320.3F
NEXT consolidation module	HM-5100SW

#### Digital Data Acquisition Setup

Data acquisition setup for Pneumatic consolidation using digital indicator and Logger

ConMatic 32 TSF or 32 Kgf/cm <sup>2</sup>	HM-5432.3F or HM-5432M.3F
Fixed ring consolidation cell	HM-1220.XX*
Digital indicator 1" x .0001" (25 x 0.002 mm)	HM-4471.10
Digital Indicator Cable, 6 ft.	HM-4470C
Humboldt Logger 4 channel digital data acquisition	HM-5330.3F
NEXT consolidation module	HM-5100SW

\* XX Requires a sample size designation, see page 122-123 for choices

#### Analog Data Acquisition Setup

Data acquisition setup for Dead-weight consolidation using analog transducer and Logger

HM-1100A	Dead weight consolidation frame
HM-1120 † or HM-1123 †	Weight set, 16 TSF Weight set, 64 kg
HM-1220.XX*	Fixed ring consolidation cell
HM-2310.04	Strain transducer 0.4" (10mm)
HM-2310BR	Strain transducer bracket
HM-5320.3F	Humboldt Logger 4 channel analog data acquisition
HM-5100SW	NEXT consolidation module

#### Digital Data Acquisition Setup

Data acquisition setup for Dead-weight consolidation using digital indicator and Logger

Dead weight consolidation frame	HM-1100A
Weight set, 16 TSF Weight set, 64 kg	HM-1120 or HM-1123
Fixed ring consolidation cell	HM-1220.XX*
Digital indicator 1" x .0001" (25 x 0.002 mm)	HM-4471.10
Digital Indicator Cable, 6 ft.	HM-4470C
Humboldt Logger 4 channel digital data acquisition	HM-5330.3F
NEXT consolidation module	HM-5100SW

† More weight choices can be found on page 123.

### Fixed Ring Consolidation Cell

ASTM: D2435, D4546, AASHTO: T216, BS:1377:5

Complete cell assembly features stainless steel construction and self-trimming cutter ring. Cutter ring rests inside clamping ring on lower porous stone, which is larger than the sample. The top porous stone and loading pad rest on the sample. The assembly is fixed on the cell base and enclosed within an acrylic cylinder open to the atmosphere, which permits saturation of the sample. The cell comes complete with all the parts illustrated in the drawing below.

**Fixed Ring Consolidation Cell**  
See Chart

Shipping wt. 7.5 lb (3kg)



Fixed Ring Consolidation Cell	
2.0"	HM-1220.20
2.42"	HM-1220.242
2.5"	HM-1220.25
3.0"	HM-1220.30
4.0"	HM-1220.40
50mm	HM-1220.50
70mm	HM-1220.70
75mm	HM-1220.75
100mm	HM-1220.100

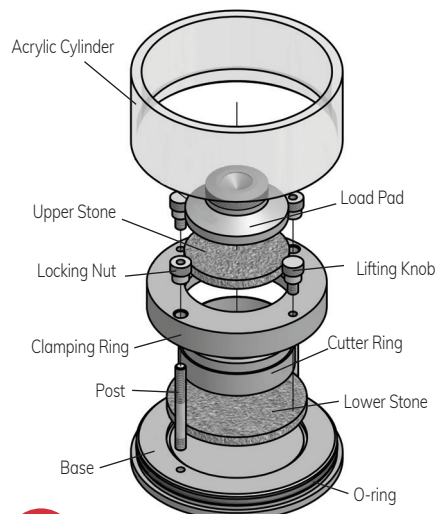

### Floating Ring Consolidation Cell

ASTM: D2435, D4546, AASHTO: T216, BS:1377:5

Complete cell assembly features stainless steel construction with self-trimming cutter ring. Similar in construction to a fixed ring cell with the exception that the lower porous stone fits inside the cutter ring and can move vertically within it. The sample ring is also free to move vertically. The cell comes complete with all the parts illustrated in the drawing below.

**Floating Ring Consolidation Cell**  
See Chart

Shipping wt. 6 lb (2.27kg)



Floating Ring Consolidation Cell	
2.0"	HM-1210.20
2.42"	HM-1210.242
2.5"	HM-1210.25
3.0"	HM-1210.30
4.0"	HM-1210.40
50mm	HM-1210.50
70mm	HM-1210.70
75mm	HM-1210.75
100mm	HM-1210.100

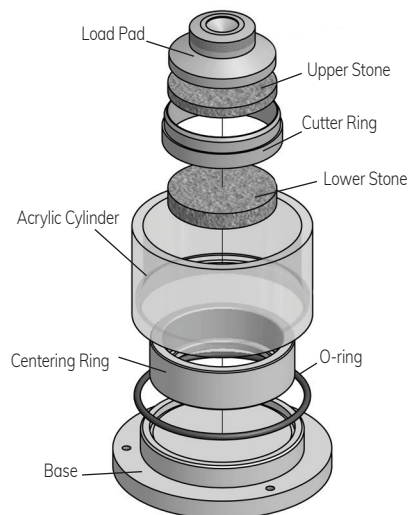

### Fixed Ring Permeability Cell

ASTM: D2435, D4546, AASHTO: T216, BS:1377:5

Similar in construction to a fixed ring cell with the exception that the saturated sample and water are sealed from the atmosphere. Complete cell assembly features stainless steel construction and self-trimming cutter ring. Base features outlet port and 10cc pipette for monitoring water level. The cell comes complete with all the parts illustrated in the drawing below, as well as a pipette.

**Fixed Ring Permeability Cell**  
See Chart

Shipping wt. 12 lb (5.4kg)



Fixed Ring Permeability Cell	
2.0"	HM-1230.20
2.42"	HM-1230.242
2.5"	HM-1230.25
3.0"	HM-1230.30
4.0"	HM-1230.40
50mm	HM-1230.50
70mm	HM-1230.70
75mm	HM-1230.75
100mm	HM-1230.100

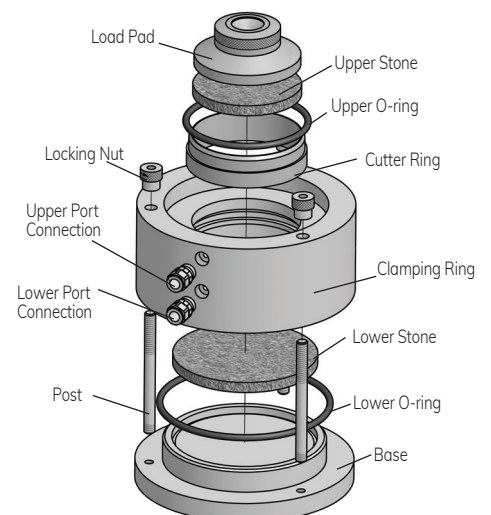

## NOTES

See next page for component details.



Load Pad	
2"	HM-1220.20.10
2.42"	HM-1220.24.10
2.5"	HM-1220.25.10
3.0"	HM-1220.30.10
4.0"	HM-1220.40.10
50mm	HM-1220.50.10
70mm	HM-1220.70.10
75mm	HM-1220.75.10
100mm	HM-1220.100.10

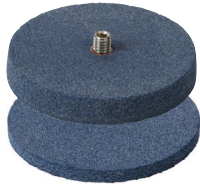

Upper Stone	
2"	HM-4184.1985
2.42"	HM-4184.240
2.5"	HM-1220.25.11 (stud)
2.5"	HM-4184.2485
3.0"	HM-4184.2985
4.0"	HM-4184.3985
50mm	HM-4184.1955
70mm	HM-4184.274
75mm	HM-4184.2940
100mm	HM-4184.3925



Lower Stone (floating)	
2"	HM-4184.1985T
2.42"	HM-4184.240T
2.5"	HM-4184.2485T
3.0"	HM-4184.2985T
4.0"	HM-4184.3985T
50mm	HM-4184.1955T
70mm	HM-4184.274T
75mm	HM-4184.2940T
100mm	HM-4184.3925T



Lower Stone (fixed, permeability)	
2"	HM-4184.331
2.42"	HM-4184.331
2.5"	HM-4184.331
3.0"	HM-4184.331
4.0"	HM-4184.4375T
50mm	HM-4184.331
70mm	HM-4184.331
75mm	HM-4184.331
100mm	HM-4184.4375T



Acrylic Cylinder (fixed-floating)	
2"	HM-1220.25.2
2.42"	HM-1220.25.2
2.5"	HM-1220.25.2
3.0"	HM-1220.25.2
4.0"	HM-1220.40.2
50mm	HM-1220.25.2
70mm	HM-1220.25.2
75mm	HM-1220.25.2
100mm	HM-1220.40.2



Centering Ring (floating)	
2"	HM-1210.20.12
2.42"	HM-1210.24.12
2.5"	HM-1210.25.12
3.0"	HM-1210.30.12
4.0"	HM-1210.40.12
50mm	HM-1210.50.12
70mm	HM-1210.70.12
75mm	HM-1210.75.12
100mm	HM-1210.100.12

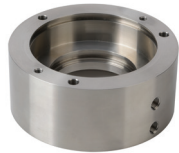

Clamping Ring (permeability)	
2"	HM-1230.20.9
2.42"	HM-1230.24.9
2.5"	HM-1230.25.9
3.0"	HM-1230.30.9
4.0"	HM-1230.40.9
50mm	HM-1230.50.9
70mm	HM-1230.70.9
75mm	HM-1230.75.9
100mm	HM-1230.100.9



Clamping Ring (fixed)	
2"	HM-1220.20.9
2.42"	HM-1220.24.9
2.5"	HM-1220.25.9
3.0"	HM-1220.30.9
4.0"	HM-1220.40.9
50mm	HM-1220.50.9
70mm	HM-1220.70.9
75mm	HM-1220.75.9
100mm	HM-1220.100.9



Base (floating/permeability)	
2"	HM-1230.25.1
2.42"	HM-1230.25.1
2.5"	HM-1230.25.1
3.0"	HM-1230.25.1
4.0"	HM-1230.40.1
50mm	HM-1230.25.1
70mm	HM-1230.25.1
75mm	HM-1230.25.1
100mm	HM-1230.40.1



Base (fixed)	
2"	HM-1220.25.1
2.42"	HM-1220.25.1
2.5"	HM-1220.25.1
3.0"	HM-1220.25.1
4.0"	HM-1220.40.1
50mm	HM-1220.25.1
70mm	HM-1220.25.1
75mm	HM-1220.25.1
100mm	HM-1220.40.1



Cutting Ring (all)	
2"	HM-1220.20.8
2.42"	HM-1220.24.8
2.5"	HM-1220.25.8
3.0"	HM-1220.30.8
4.0"	HM-1220.40.8
50mm	HM-1220.50.8
70mm	HM-1220.70.8
75mm	HM-1220.75.8
100mm	HM-1220.100.8



Calibration Disk	
2"	HM-1220.20.4
2.42"	HM-1220.24.4
2.5"	HM-1220.25.4
3.0"	HM-1220.30.4
4.0"	HM-1220.40.4
50mm	HM-1220.50.4
70mm	HM-1220.70.4
75mm	HM-1220.75.4
100mm	HM-1220.100.4

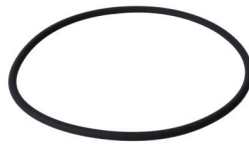

Lower o-ring (floating/permeability)	
2"	HM-003053
2.42"	HM-003053
2.5"	HM-003053
3.0"	HM-003053
4.0"	HM-003056
50mm	HM-003053
70mm	HM-003053
75mm	HM-003053
100mm	HM-003056

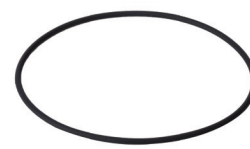

Lower o-ring (fixed)	
2"	HM-003052
2.42"	HM-003052
2.5"	HM-003052
3.0"	HM-003052
4.0"	HM-003024
50mm	HM-003052
70mm	HM-003052
75mm	HM-003052
100mm	HM-003024



Upper o-ring (permeability)	
2"	HM-003057
2.42"	HM-003058
2.5"	HM-003054
3.0"	HM-003059
4.0"	HM-003060
50mm	HM-003057
70mm	HM-003061
75mm	HM-003062
100mm	HM-003063





Filter Paper	
2"	HM-4189.20
2.42"	HM-4189.25
2.5"	HM-4189.25
3.0"	HM-4189.30
4.0"	HM-4189.40
50mm	HM-4189.20
70mm	HM-4189.28
75mm	HM-4189.30
100mm	HM-4189.40



Post	
ALL	HM-1220.25.3



Locking Nut	
ALL	HM-1220.25.5

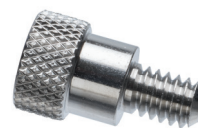

Lifting Knob	
ALL	HM-1220.25.6



5/8" Pressure Ball (Stainless)	
ALL	HM-001076



Port Connection Upper (Permeability)	
ALL	HM-003027



Port Connection Lower (Permeability)	
ALL	HM-003055



HM-1240.25

### Trimming Turntable for 2.5" Specimens

Trims samples down to correct sizing.

Trimming Turntable, 2.5" Specimens HM-1240.25

Shipping wt. .5lb (2.27kg)

### Shear & Consolidation Install Kit Components

.25" OD Tubing, 100ft.	HM-4196.25
.375" to .25" Reducer Bushing (3)	HM-4150.77
Cutter, Flexible Tubing (1)	HM-000058
Thread Tape, PTFE (1)	HM-000059
Wrench, Adjustable, 6" (1)	HM-000064
Union T Fitting, .25" (5)	HM-4150.45
Quick Valve Coupling, .25" (2)	HM-4150.72
Regulator Elbow, .25" (3)	HM-4150.44
Tube Fitting T, 6mm OD (5)	HM-003175
Push-to-Connect Tube Fitting Coupler, .25" OD (4)	HM-003176



HM-4168

### Shear & Consolidation Installation Kit

Kit designed to provide fittings, connectors, tubing and tools to complete an installation set up. Kit includes items in the table below. All items can be purchased individually as well, see chart to left.

Shear & Consolidation Installation Kit HM-4168

Shipping wt. 4.5 lbs (2.04kg)

### Weight Sets for Consolidation and Direct Shear Testing

Weight Set	Set Includes	Model No.	Ship. Wt.
16 TSF Set	(2) .125 TSF, (1) .25 TSF, (1) .50 TSF, (1) 1.0 TSF, (1) 2.0 TSF, (3) 4.0 TSF weights	HM-1120	140 lbs. (64kg)
32 TSF Set	(2) .125 TSF, (1) .25 TSF, (1) .50 TSF, (1) 1.0 TSF, (1) 2.0 TSF, (7) 4.0 TSF weights	HM-1121	275 lbs. (125kg)
32 kg Set	(4) 1 kg, (3) 4 kg, (2) 8 kg weights	HM-1122	73 lbs. (33.1kg)
50 kg Set	(3) 1 kg, (1) 2 kg, (1) 5 kg, (4) 10 kg weights	HM-1125	110 lbs. (50kg)
64 kg Set	(4) 1 kg, (5) 4 kg, (5) 8 kg weights	HM-1123	150 lbs. (68kg)
88 kg Set	includes: (4) 1 kg, (5) 4 kg, (8) 8 kg weights	HM-1124	130 lbs. (59kg)



HM-1120

### Individual Weights for Consolidation and Direct Shear Testing

Individual Weights: Kg		Individual Weights: TSF	
Weight	Model No.	Weight	Model No.
0.5kg	HM-1122.05	0.125 (1/8)	HM-1120.125
1.0kg	HM-1122.1	0.25 (1/4)	HM-1120.250
2.0kg	HM-1122.2	0.50 (1/2)	HM-1120.500
4.0kg	HM-1122.4	1.0	HM-1120.1
5.0kg	HM-1122.5	2.0	HM-1120.2
8.0kg	HM-1122.8	4.0	HM-1120.4
10.0kg	HM-1122.10		

[www.humboldtmg.com](http://www.humboldtmg.com)

1.800.544.7220

