



Humboldt Mfg. Co.
www.humboldtmfg.com
875 Tollgate Road
Elgin, Illinois 60123 U.S.A.

U.S.A. Toll Free: 1.800.544.7220
Voice: 1.708.468.6300
Fax: 1.708.456.0137
email: hmc@humboldtmfg.com

Operating Manual

Laboratory Mortar Mixer

Model 1.0203

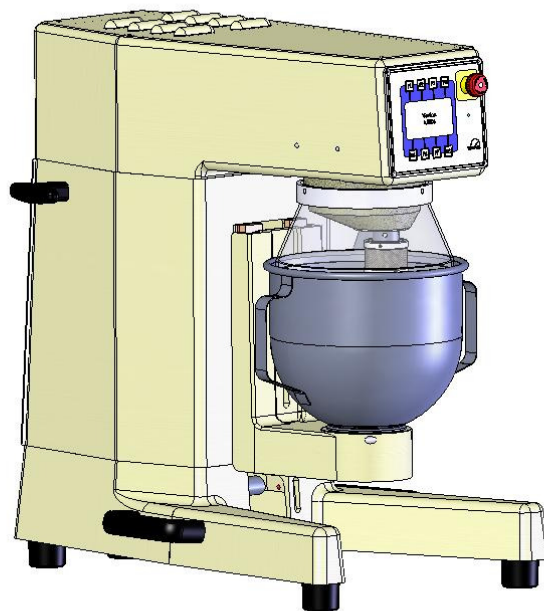

Importance of this Operating Manual:

We expect and require that the User reads, understands, and observes all parts of this Operating Manual.



Contents:	Page no.:
1. Receiving the system from the forwarding agent; transport.....	5
1.1 Receiving the system from the forwarding agent	5
1.2 Transport.....	5
1.3 Removal of the transport packing.....	6
1.4 Manual transport	6
2. Scope of delivery.....	7
3. Basic safety instructions.....	7
3.1 Responsibilities of the User and Operator.....	7
3.2 Responsibilities of the operating staff.....	7
3.3 Responsibilities of the operating staff.....	8
3.4 Workplace for the Laboratory Mortar Mixer	8
3.5 Danger while working with the Laboratory Mortar Mixer.....	8
4. Basic instructions	8
4.1 Purpose for which this system has been designed	8
4.2 Use of this product for purposes for which it was not intended	10
4.3 Information on the European Conformity Mark (CE mark)	11
4.4 Obligations of the Operator / User.....	11
4.5 General safety instructions.....	13
4.6 Protective clothing.....	15
4.7 Regular checks of the Laboratory Mortar Mixer	15
5. Description of the Laboratory Mortar Mixer.....	15
5.1 Mechanical design.....	15
5.2 Electrical ratings.....	15
5.3 Safety devices	16
6. Preparations for putting the Laboratory Mortar Mixer into operation	17
6.1 Location of the Laboratory Mortar Mixer and its ambient conditions	17
6.2 Connecting the Laboratory Mortar Mixer to the power supply	18
6.3 Checking the direction of mixer rotation	18
6.4 Changing the direction of rotation	19
6.5 Lowering the mixing bowl and removing it.....	19
6.6 Unlocking and removing the stirrer.....	20
6.7 Placing the stirrer into operating position and locking it there	20
6.8 Placing the mixing bowl into position and locking it there.....	20
6.9 Placing the mixing bowl into its mixing position.....	20
6.10 Checking the interval between the stirrer and the mixing bowl.....	20
6.11 Adjusting the interval between the mixing bowl and the stirrer.....	21
7. Technical data	21

8. Operation of the machine	23
8.1 Switching on the Laboratory Mortar Mixer	23
8.2 Description of the operator control unit	23
8.3 Explanation of symbols	24
8.4 Conditions that must be fulfilled before the Laboratory Mortar Mixer will start	25
8.5 Display and operator-control unit	26
8.6 Manual operation	28
8.7 Error messages	31
8.8 Switching off the Laboratory Mortar Mixer	31
9. Guarantee	31
10. Date of issue of this Operating Manual	32
11. Copyright	32
12. Address of the manufacturer	33
13. Cleaning and maintenance	33
13.1 Cleaning of the Laboratory Mortar Mixer	33
13.2 Maintenance of the mortar mixer	34
13.3 Inspection and adjustment	34
13.4 Procedure for shutting down the Laboratory Mortar Mixer for longer periods of time	34
14. After-sales service and ordering spare parts	35
15. Scrapping the Laboratory Mortar Mixer	35
16. Rear side of the display and operator-control unit	36
17. I/O circuit board	37

Attachments:

Test Report

The symbols pictured below have the following meaning:

<p>Caution!</p> 	<p>This cautionary alert is given for all procedures that must be conducted with caution, in order to prevent damage to the equipment.</p>
<p>Danger!</p> 	<p>This warning is given for all procedures that could represent a risk to the Operator if work is not carefully carried out.</p>
<p>Note</p> 	<p>This note gives practical instructions for using the device.</p>

1. Receiving the system from the forwarding agent; transport

1.1 Receiving the system from the forwarding agent

When the system arrives from the forwarding agent, make an external inspection. If there are no visible damages or other shortcomings, accept the consignment from the freight forwarder (the package service or a haulage agent).

If there are no transport damages or other shortcomings, use the bill of delivery to check to make sure that the delivery is complete.

If you discover after you have accepted the delivery that transport damage has occurred, immediately make a report of this damage, with an exact description and a photo of the nature and the extent of the damage. Send this report to us immediately by fax. Important: Be absolutely sure not to make any changes or other alterations to the system as it has been delivered.

When we receive this report, we shall decide whether we can solve the difficulty by one of the following steps:

- Delivery to you of spare parts
- Sending a specialist fitter or mechanic to your company
- Asking for return of the system to us for replacement or repair.

1.2 Transport

The Laboratory Mortar Mixer is delivered in especially designed cardboard boxes standing on a pallet.



The weight (mass) of the Laboratory Mortar Mixer is approximately 62 kg. You can transport the Laboratory Mortar Mixer to its place of operation, while it still remains in the original packing, by means of a fork-lift truck or other suitable floor handling equipment that can reach under the pallet.

Do not use ropes, fastening tackle, or other hoisting gear to wrap around the machine and lift it – unless you can ensure that no lateral forces will act on the packing or on any parts of the Laboratory Mortar Mixer.

1.3 Removal of the transport packing

Remove the transport packing as follows:

- Open the cover of the transport packing
- Remove the carton or polystyrene safety cushioning packed into the boxes
- Cut open the side walls of the packing at the vertical edges
- Cut off the side walls of the packing at the horizontal edges of the bottom of the packing

<p>Danger!</p> 	<p>Do not allow children to have access to this packing material. This includes plastic, polystyrene, screws and bolts, nails, wood, and the like. Dispose of these materials in accordance with valid local laws and regulations.</p>
<p>Caution!</p> 	<p>Before disposing of the packing, make sure that no accessories, instructions, documents, or spare parts are still in the boxes.</p>

After you have unpacked the machine, check to make sure that there are no obvious damages from the forwarding and transport. If you are not sure, **do not** connect the machine, and get in touch with the dealer who has sold it to you.

1.4 Manual transport

You can transport the Laboratory Mortar Mixer to its place of transport by hand. Its weight (mass) is approximately 62 kg.

To lift the Laboratory Mortar Mixer by hand, use the lower handles installed on the sides at the centre of gravity. They are each designed to support 40 kg.

The T-shaped handles installed in the lower area are provided to help stabilize the Laboratory Mortar Mixer while it is being carried.

You can use the handles to conveniently lift the Laboratory Mortar Mixer to its final place of operation, and to set it down there.

Three handles are provided only for transport of the Laboratory Mortar Mixer by hand. They must not be used to attach lifting or hoisting equipment.

2. Scope of delivery

Item	Quantity	Designation	Article number
1.	1	Laboratory Mortar Mixer, including Operating Manual	1.0203
2.	1	Stainless-steel stirrer	1.0203.02
3.	1	Stainless-steel bowl	1.0203.03

3. Basic safety instructions

3.1 Responsibilities of the User and Operator

This Operating Manual must be kept in a place that is easily accessible and that is near the Laboratory Mortar Mixer. Only sufficiently qualified staff may work with the Laboratory Mortar Mixer. Before working with the Laboratory Mortar Mixer, the persons who will operate this equipment must be sufficiently trained. The supervisor of these persons must check to make sure that they have read and understood this Operating Manual. The supervisor must also determine exactly what responsibilities that he will assign to each of these persons. The operating staff must be equipped with the required personal protective gear.

The person operating this system must take care that he or she does not endanger the health and safety of himself/herself, or of any other persons.

If any deficiency or damage to the Laboratory Mortar Mixer is determined that impairs its operational safety, the Laboratory Mortar Mixer must be immediately taken out of operation. It may be used again only after elimination of all sources of danger.

3.2 Responsibilities of the operating staff

Only sufficiently qualified specialist staff may work with the Laboratory Mortar Mixer. These must be persons who have been trained in work with the Laboratory Mortar Mixer, and who have been assigned to work with it by their authorized supervisor. Persons operating the Laboratory Mortar Mixer must be at least eighteen (18) years old. Persons under 18 years of age may operate the Laboratory Mortar Mixer only under the supervision of a fully qualified specialist technician.

3.3 Responsibilities of the operating staff

Any person working with the Laboratory Mortar Mixer must first carefully read this Operating Manual. These persons must by all means observe the safety regulations. They must wear personal safety equipment while working with the Laboratory Mortar Mixer.

3.4 Workplace for the Laboratory Mortar Mixer

The workplace for the Laboratory Mortar Mixer is located at the control panel in front of the Laboratory Mortar Mixer. This workplace is defined by the periphery connected to the Laboratory Mortar Mixer by the User. The Operator of the Laboratory Mortar Mixer must ensure that this workplace is organized in a safe manner. The organization of the workplace must also be in accordance with the relevant stipulations set forth in the German Law on Occupational Safety (BetrSichV) and on the Danger Analysis of the Workplace.

3.5 Danger while working with the Laboratory Mortar Mixer

This system has been designed and built in accordance with the state of the engineering art and with the accepted rules of good engineering practice. The use of this system, however, can result in danger to life and limb of the Users and third parties, and can cause damage to mechanical-engineering components and other items of property.

This Laboratory Mortar Mixer may be used only:

- For the purpose for which it was intended, and
- While it is in a technical state that is entirely safe.

Any malfunctions or other difficulties that could represent a danger must be eliminated immediately.

4. Basic instructions

4.1 Purpose for which this system has been designed

This Operating Manual contains the information required for operation of the products described here, for the purpose for which they have been designed. This Operating Manual is intended to be used only by technically qualified staff. The Owner and Operator of this Laboratory Mortar Mixer must exactly determine the areas of responsibility of those persons who will work with and near this equipment.

“Technically qualified staff” is defined as those persons who – as a result of their training; their experience; the instructions which they have received; as well as their knowledge of the relevant standards, regulations, accident-prevention regulations, and conditions of product operation in the company – have been authorized by the person responsible for the safety of the machine operation to carry out the activities and actions required for operation of the products described below, and who can recognize and prevent any possible dangers arising from such operation (this definition of technically qualified staff has been provided in IEC 364).

The Owner and Operators must by all means observe the requirements and limit values, as well as all safety instructions, given in this Operating Manual. Any use of this device not in conformity with these stipulations shall be considered to be in violation of the use for which this system was intended. If this device must be operated under special conditions, or with special modes of operation, then this shall be authorized only after consultation with the Manufacturer, and after obtaining his prior and express approval.

The Manufacturer of this equipment cannot be held responsible for any damages that may occur because the instructions in this Operating Manual and its safety rules have not been observed.

This Laboratory Mortar Mixer serves only for the mechanical mixing of mortar and cement paste to be used to produce test specimens in accordance with various standards.

The following-listed applications are included in the purposes for which this Laboratory Mortar Mixer was intended:

- **Manual** operation with mixing speeds that can be selected.
During this application, the Operator must by all means observe the instructions, limit values, and safety rules contained in this Operating Manual.

<p>Note</p> 	<p>This Laboratory Mortar Mixer is designed for operation in dry rooms.</p>
--	---

Any use of the Laboratory Mortar Mixer for any other purposes shall be considered as an application for purposes for which it was not intended. Any use of this device not in conformity with these stipulations shall also be considered to be in violation of the use for which this system was intended. If this device must be operated under special conditions, or with special modes of operation, then this shall be authorized only after consultation with the Manufacturer, and after obtaining his prior, express, and written approval.

<p>Note</p> 	<p>The instructions provided in this Operating Manual apply only to the correct use of the Laboratory Mortar Mixer. In order to perform the necessary testing correctly, the User must observe the specific standards for such testing.</p>
---	---

- This Operating Manual is intended to be read and followed by the freight carrier, the fitters and installers, the Operators and Users, the service and repair staff, and the persons who must dispose of (scrap) the system.
- It is absolutely necessary to read and understand all the instructions in this Operating Manual in order to properly and safely operate this Laboratory Mortar Mixer.
- This Operating Manual must be considered as a constituent component of the product. It may be used only together with the Laboratory Mortar Mixer with which it has been delivered.
- This Operating Manual must be kept closely at hand and in good condition throughout the entire service life of the machine. It must be immediately available whenever it is needed.
- If this Laboratory Mortar Mixer is sold, the Operating Manual and all its attachments must be passed on to the new Owner.
- The Manufacturer may not be held liable for any damages that arise as a result of improper use or handling of the Laboratory Mortar Mixer.
- The Manufacturer reserves the right to modify these technical descriptions, as well as the machines and components that it refers to, without prior notice.

4.2 Use of this product for purposes for which it was not intended

This Laboratory Mortar Mixer may be used only in fully satisfactory condition.

Use this Laboratory Mortar Mixer only for the purposes described in this Operating Manual. If this system is improperly used, or used for purposes for which it was not intended, the guarantee will not be valid.

If the User or Operator tempers with this Laboratory Mortar Mixer or makes any modifications to it (i.e., changes of electrical, mechanical, or other nature) that have not been approved expressly in advance and in writing by the Manufacturer, these changes shall be considered to be forbidden. In such cases, the Manufacturer cannot accept liability for any damages that may result.

We recommend that the User or Operator uses only original spare parts and accessory parts. Otherwise, the Manufacturer cannot accept liability for any damages that may result.

Do not allow any dangerous situations to arise during work with the Laboratory Mortar Mixer. If the Laboratory Mortar Mixer does not function correctly, immediately switch it off, and then notify the Manufacturer or the authorized service staff of the Dealer without delay.

This Laboratory Mortar Mixer was **not intended** for the following uses or conditions of use, which **are not allowed**:

- Mixing of materials that are different from those given under Section 4.1 in this Operating Manual.
- Filling the mixing bowl with foods or beverages and the attempt to process them.
- Mixing when the mixing bowl has been over-filled.
- Operation under ambient conditions that are different from those given under Section 4.1 in this Operating Manual.

4.3 Information on the European Conformity Mark (CE mark)

Testing equipment from TESTING Bluhm & Feuerherdt carries the European Conformity Mark (CE Mark).

The CE Mark confirms the conformity of the product with the EG Directives applying to the product as well as observance of the “Basic Requirements” contained in these Directives. It also confirms that the product conforms with the generally relevant level of protection stipulated by these Directives. The procedure for evaluating the degree of conformity was conducted in all cases in accordance with the applicable EG Directives. The basis for conformity verification is the Decision of the EU Commission, 93 / 465 / EWG, concerning the modules to be applied for technical harmonization procedures, as well as the rules applying to the affixing and usage of the CE Mark.

4.4 Obligations of the Operator / User

The Operator of the Laboratory Mortar Mixer is responsible to ensure that he or she does not endanger himself/herself or any other persons in the operation of this equipment. Only those persons may operate the Laboratory Mortar Mixer who have been especially instructed in its use.

If any deficiency, shortcoming, trouble, or damage to the Laboratory Mortar Mixer could impair its operating safety, it must be immediately shut down. It may be used again only after all sources of danger have been eliminated.

Make sure that the ratings of your electrical mains systems are the same as the information on the rating plate of your Laboratory Mortar Mixer. Connect this Laboratory Mortar Mixer only to three-phase alternating current.

If the Laboratory Mortar Mixer or its power cable has become damaged, immediately disconnect the power cable from the mains power source.

<p>Danger</p> 	<p>During mixing, you must take the necessary protective measures to prevent dust from entering the eyes, mouth, or nose of any persons around the Laboratory Mortar Mixer.</p>
---	---

- Only properly qualified staff may use, lift, install, service, repair, or scrap the Laboratory Mortar Mixer. “Properly qualified staff” is defined as those persons who – as a result of their training; their experience with the Laboratory Mortar Mixer; the instructions which they have received; as well as their knowledge of the relevant standards, regulations, accident-prevention regulations, and conditions of product operation in the company – have been authorized by the person responsible for the safety of the machine operation to carry out the activities and actions required for operation of the Laboratory Mortar Mixer. The User must be carefully trained in operation of the machine, as well as in the safety devices with which the machine is equipped, in order to prevent improper use of the Laboratory Mortar Mixer. Safety devices must always remain installed and must be checked on a daily basis.
- If the User or Operator tempers with this Laboratory Mortar Mixer or makes any modifications to it (i.e., changes of electrical, mechanical, or other nature) that have not been expressly approved in advance and in writing by the Manufacturer, these changes shall be considered to be forbidden. In such cases, the Manufacturer cannot accept liability for any damages that may result.
- Make sure that no dangerous situations can arise during work. In case the machine does not properly function, switch it off immediately and notify the Manufacturer or the authorized service staff of the Dealer without delay.
- Do not insert wires or tools in the openings of the Laboratory Mortar Mixer.

4.5 General safety instructions

<p>Caution!</p> 	<p>Read and observe all instructions here. If the User or Operator does not observe the following instructions, this can result in electrical shock, fire, and/or severe injuries.</p>
---	--

1) Workplace requirements

- Keep your workplace clean and tidy and well illuminated. Workplaces that are not tidy or well lighted can lead to accidents.
- Do not work with the Laboratory Mortar Mixer in a potentially explosive environment: i.e., one in which combustible liquids, gases, or dust is found. Electrical tools can produce sparks that can cause dust, gas, and vapours to burn or explode.
- While you are using the Laboratory Mortar Mixer, do not allow children or other persons to come near the machine. If such persons distract your attention, you could lose control over the Laboratory Mortar Mixer.

2) Electrical safety

- The plug of the power cable of the Laboratory Mortar Mixer (CEE / 16A) must match the electrical power socket with which it is being used. The plug must fit into the socket, and the plug may not be modified in any way. Do not use adapter plugs together with protectively earthed equipment. Operations with the original, unchanged plugs, together with matching power outlets, reduce the risk of electrical shock.
- In connection with operation of the Laboratory Mortar Mixer, do not allow your body to come into contact with earthed (grounded) surfaces such as pipes, heating radiators, stoves, hobs, or refrigerators. If your body is earthed, there is a greater risk of electrical shock while working with or around the Laboratory Mortar Mixer.
- Do not allow rain or other moisture to cause the Laboratory Mortar Mixer to get wet. If water penetrates into an electrical device, it will increase the risk of electrical shock.
- Do not use the power cable to move or carry the Laboratory Mortar Mixer, or to hang it up. Do not unplug the machine by pulling on the power cable. Do not allow the power cable to come into contact with heat, oil, sharp edges, or moving parts of equipment. Damaged, kinked, or twisted cables increase the danger of electrical shock.

3) Safety of persons

- Pay careful attention to what is going on around your work. Be careful of what you are doing. Use common sense in your work. Do not use this machine if you are tired or under the influence of drugs, alcohol, or medication. One moment of carelessness in using this machine can lead to serious injuries.
- Wear personal protective gear, and always use safety glasses. The use of protective gear – such as a dust mask or non-slip safety shoes – reduces the danger of injuries.
- Before you switch on this machine, remove all setting tools or spanners (wrenches) that you have used on the Laboratory Mortar Mixer. A spanner or other tool, if left in a rotating part of this machine, can cause personal injuries.
- Wear suitable clothing. Do not wear jewellery or floppy clothing. Keep hair, clothing, and gloves away from the moving parts. Floppy clothing, jewellery, and long hair can become caught in moving parts.

4) Careful handling and use of electrical tools

- Before you make settings on the machine or exchange accessory parts, be sure to remove the power plug from the electrical power outlet. This safety measure will prevent the Laboratory Mortar Mixer from starting by accident.
- Do not allow children to have access to electrical tools. Do not allow any persons to use this machine who are not familiar with it or who have not read this Operating Manual. Electrical tools are dangerous if they are used by persons who do not have experience with them.
- Carefully check the Laboratory Mortar Mixer. Make sure that all its moving parts properly function, and that they have not jammed. Check to see whether parts have been broken, or if some are damaged to the extent that they impair the proper functioning of the machine. If parts are damaged, have them repaired before using the machine again. Poorly maintained or serviced machines are the cause of many accidents.
- Use electrical tools, machine accessories, tool attachments, and the like in accordance with this Operating Manual. Use these items in the manner in which they are intended for use for this special type of machine. Make sure to take full account of the conditions under which they will be used in work, and of the activities that you will perform with them. The use of electrical tools for any purpose other than that for which they were intended can lead to dangerous situations.

5) Service

- Allow your machine to be repaired or serviced only by qualified specialist personnel. For repairs, allow only original spare parts to be used. This will ensure that the safety of the machine will not be compromised.

4.6 Protective clothing

The User or Operator must ensure that the persons operating the Laboratory Mortar Mixer always wear the protective gear and clothing required for each task. For example:

- Safety shoes
- Effective outer clothing
- Protective gloves
- Face protection
- Respiratory protection.

4.7 Regular checks of the Laboratory Mortar Mixer

The Laboratory Mortar Mixer must be subjected to work-safety checks on a regular basis. National laws and regulations prescribe what inspections must be made.

5. Description of the Laboratory Mortar Mixer

5.1 Mechanical design

The housing of the Laboratory Mortar Mixer consists of sturdy light-metal casting.

The stirrer is made of non-corrosive steel and is coupled to the planetary geartrain by a fast-on connection. The stirrer turns on its own axis and is powered by an electrical motor with two speeds in planetary motion around the axis of the mixing bowl.

The mixing bowl consists of stainless steel, Nirosta grade. After the machine has lowered it from its operational position, the Operator can remove it from the machine.

The outer contours of the stirrer and the mixing bowl are exactly coordinated, and guarantee an interval of 3.0 ± 1.0 mm between the stirrer blades and the mixing-bowl surface. The User can adjust this interval by unscrewing the two clamp screws provided: see Section 6.11 for detailed instructions.

5.2 Electrical ratings

The power supply for the mixer must have the following ratings: **3 x 400 V + N + PE, 50 Hz**. Connection to the power supply is by a 5-pole plug that is in accordance with the specifications in the pertinent CEE standard. The User can change the direction of stirrer rotation without opening the housing of the power-cable plug and making a swap there: see Section 6.4 in this Operating Manual for the instructions. The main power

switch is located on the right-hand head side of the Laboratory Mortar Mixer (when seen from the front). This power switch separates all poles of the Laboratory Mortar Mixer from the mains power supply.

1) Components in the rear space of the Laboratory Mortar Mixer:

- I/O printed circuit board, on an installation frame that can be swivelled out
Swivelling out the installation frame provides accesses to the terminals of the power-connection cable and to the fusible cutouts (fusegear) for the short-circuit protection of the Laboratory Mortar Mixer.

2) Components in the head space of the Laboratory Mortar Mixer:

- Connection terminals of the 3-pole main power switch

3) Display and operator-control unit of the Laboratory Mortar Mixer:

- 16-bit CPU, Hitachi H8 2646, 16-byte internal Flash, 1-kbyte RAM
- Display
- Multi-colour signal light for showing that the machine is ready for operation
- Eight function keys
- Signal buzzer
- Emergency OFF switch than can be unlocked
- Programming interface

The operator display and control unit is connected by a plug-in, shielded control cable to the I/O circuit board on the installation frame that can be swivelled out.

5.3 Safety devices

The Laboratory Mortar Mixer is equipped with the following safety devices:

1. Emergency OFF switch

Pressing the emergency OFF switch will cause the 3-pole safety module to separate the drive motor from the electrical power supply. To activate the control system again, the Operator must turn the emergency OFF switch in the direction of the arrow to put it back in its starting position.

2. Inductive electronic proximity switch in the mount of the mixing bowl

The operation of the proximity switch in the mount of the mixing bowl is circumvented (attenuated) by the presence of the bottom flange of the mixing bowl. It

therefore monitors the correct seating of the bowl in its mount. If the bowl is in place, the Laboratory Mortar Mixer can function normally.

But if the mixing bowl is not placed into its mount, the safety module will prevent the operation of the Laboratory Mortar Mixer. A feedback alert will be sent via the display and operator-control unit.

3. Inductive electronic proximity switch in the lifting device for the mixing bowl

When the mixing bowl reaches its mixing position, this will circumvent (attenuate) the proximity switch for the bowl-lifting system. This proximity switch will then monitor the mixing bowl to make sure that it is in the correct mixing position. If the mixing bowl is not in its correct mixing position, the safety module will prevent the operation of the Laboratory Mortar Mixer. A feedback alert will be sent via the display and operator-control unit.

4. Fixed protective cover

A protective cover encloses the stirring apparatus on all sides when the mixing bowl is in mixing position.

6. Preparations for putting the Laboratory Mortar Mixer into operation

6.1 Location of the Laboratory Mortar Mixer and its ambient conditions

<p>Caution!</p> 	<p>Important: operation of the Laboratory Mortar Mixer is possible only in dry rooms.</p>
---	--

The following limit values must be observed here:

- Ambient temperature: DIN EN 60204-1, 4.4.2 +5 °C ... +40 °C
- Relative humidity: DIN EN 60204-1, 4.4.3 30 % ... 95 %

<p>Note</p> 	<p>Set up the Laboratory Mortar Mixer on a flat, level surface which is sufficiently strong enough to support its weight.</p>
---	---

6.2 Connecting the Laboratory Mortar Mixer to the power supply

A **CEE 16-A mains power outlet** with ratings of **400 V 3-phase + 1N + 1PE, 50 Hz** is required for connection of the power plug of the Laboratory Mortar Mixer.

Use a **16-A CEE** plug to connect the 5-conductor power cable of the Laboratory Mortar Mixer to the mains power outlet.

6.3 Checking the direction of mixer rotation

<p>Caution!</p> 	<p>To prevent damage to the Laboratory Mortar Mixer, it is absolutely necessary to perform the check for direction of rotation as described in the following.</p>
---	---

Procedure for checking the direction of rotation of the mixer:

1. Connect the Laboratory Mortar Mixer to the mains power supply by inserting the five-pole CEE mains power plug into the required power outlet (see above).
2. Unlock the emergency OFF switch by turning it in the clockwise direction.
3. Place the main power switch in the “I” position (ON).
4. Place the stirrer in position and lock it there (see Section 6.7).
5. Place the mixing bowl into its mount and lock it there (see Section 6.8).
6. Place the mixing bowl into mixing position (see Section 6.9).
7. On the operator-control module, press key F6 for the speed “62/140 rpm”.
8. Determine that the direction of rotation of the gearhead is correct (if it is not correct, see Section 6.4 below).
9. To shut down the Laboratory Mortar Mixer, first set key F6 to 0.
10. Then place the main power switch to “O” (OFF).
11. Remove the CEE power plug from the power outlet.

<p>Caution!</p> 	<p>The mixing head must turn in the direction of the arrow on the machine, in the anti-clockwise (counterclockwise) direction. This will cause the stirrer to move in the opposite (clockwise) direction.</p>
---	---

If the mixing head turns **in the direction of the arrow** (anti-clockwise), then the Laboratory Mortar Mixer is ready for operation.

If the mixing head turns **against the direction of the arrow** (clockwise), then the direction of rotation must be changed as described in Section 6.4.

6.4 Changing the direction of rotation

You can change the direction of mixer rotation without opening the plug case.

First remove the power plug from the power outlet. Then use a screwdriver to exchange the phases on the contact side of the power plug. To do this, insert the screwdriver into the slot provided on the contact side of the plug, and turn it 180 °.



<p>Caution!</p> 	<p>Safety warning! Work on electrical equipment may be performed only by qualified specialist staff.</p>
---	--

6.5 Lowering the mixing bowl and removing it

Locate the hand lever on the right side of the Laboratory Mortar Mixer and turn it to the right until it unlocks. Then rotate it as far as it will turn toward the front. This will lower the mixing bowl.

The bowl mount is now in its lowered position. Use the handles on the side of the mixing bowl to turn it in anti-clockwise direction, until the two arrows on the mixing bowl and on

the bowl mount are vertically in line (one over the other). Lift the mixing bowl upward and slightly toward the front, until the eccentric clamp is no longer in the bowl mount. Now tip the mixing bowl toward the rear and remove it from the machine.

6.6 Unlocking and removing the stirrer

Use your left hand to firmly grip the stirrer, and firmly grip the knurled ring of the stirrer mount with your right hand. Unscrew the knurled ring in the anti-clockwise direction, until it can be shoved upward. Now pull the stirrer down to remove it.

6.7 Placing the stirrer into operating position and locking it there

Insert the stirrer with a slight turning motion until you feel it has reached its limit in the fast-action clamp of the stirrer head. Hold the stirrer with your left hand and turn the knurled ring until it falls about 10 mm downward. Now use your right hand to lock the knurled ring by turning it in the clockwise direction.

6.8 Placing the mixing bowl into position and locking it there

Make sure the mount of the bowl is in its lowered position. To place the mixing bowl into its mixing position, grip it by using its handles on the side. The red arrow must point toward the front. Now place the mixing bowl into position so that the two arrows on the bowl and on the bowl mount are vertically in line (one above the other). Now tilt the bowl slightly toward the front and allow it to slide easily into place. Now turn the mixing bowl in the clockwise direction to lock it into place.

6.9 Placing the mixing bowl into its mixing position

Turn the hand lever first to the right, then toward the rear, until it has reached its limit. Then lock it into place by turning it to the left. This will lock the mixing bowl into mixing position.

6.10 Checking the interval between the stirrer and the mixing bowl

Lower the mixing bowl and remove it (as described in Section 6.5). Then unlock the stirrer and remove it (as described in Section 6.6). Next, remove the finger guard by unscrewing the 3 hexagonal recessed cap screws on the collar of the finger guard, and then removing the finger guard downward. Now place the stirrer back into mixing position and lock it there (as described in Section 6.7). Then place the mixing bowl into position and lock it there (as described in Section 6.8). As next step, place the mixing bowl into its mixing position (as described in Section 6.9). Use the interval gauge (special tool

provided by TESTING, article no. 1.0203.07) to measure the interval between the stirrer and the mixing bowl: according to EN 196-T1, this must be 3.0 ± 1.0 mm. If the interval conforms to this regulation, you may re-attach the finger guard and use the machine as usual. If the interval does not conform to this standard, it must be adjusted as described in Section 6.11.

6.11 Adjusting the interval between the mixing bowl and the stirrer

If the interval between the mixing bowl and the stirrer is larger than the standard allows, it is necessary to adjust this interval. To adjust this interval, first lower the mixing bowl and remove it, as described in section 6.5. Then loosen the two clamping screws on the mount for the mixing bowl, by unscrewing them approximately one turn. Now unscrew the locknut that secures the adjustment screw, on the upper end of the mount for the mixing bowl. Next, use the adjustment screw on the mount for the mixing bowl to adjust the interval between the mixing bowl and the stirrer. Use the interval gauge (special tool provided by TESTING, article no. 1.0203.07) to measure the interval between the mixing bowl and the stirrer.

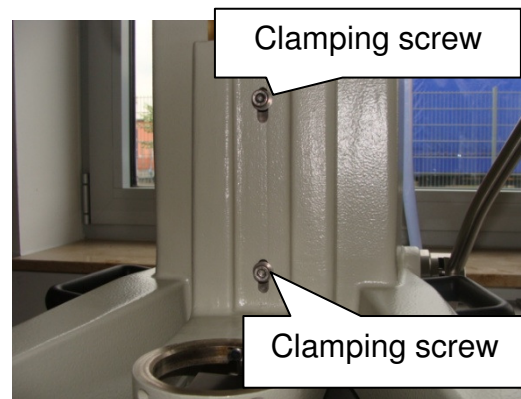

- Turn the adjustment clockwise to reduce the interval.
- Turn the adjustment anti-clockwise to increase the interval.

When the interval has been correctly adjusted, then tighten the locknut, the adjustment screw, and the 2 clamping screws on the mount for the mixing bowl. Now install the finger guard once again, and place the mixing bowl and the stirrer in their proper positions.

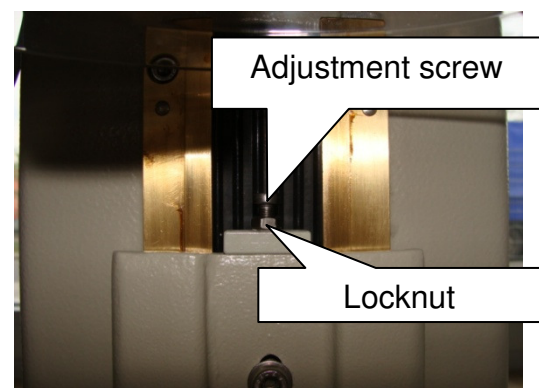

7. Technical data

Footprint of the machine	approx. 300 x 550 mm	Power consumption	0.20 / 0.37 kW
Installed height	approx. 500 mm	Three-phase power rating	400 V
Weight (mass)	approx. 62 kg	Frequency	50 Hz
		Number of power phases	3
		Slow-blow micro-fuse	5 x 20 mm / 250 V / 2.5 A

Speeds of revolution of the Laboratory Mortar Mixer in accordance with DIN EN 196-1

	Rotation (rpm)	Planetary motion (rpm)
Low speed	140 ± 5	62 ± 5
High speed	285 ± 10	125 ± 10

**Schematic representation of the drive components
(opposed direction of rotation)**

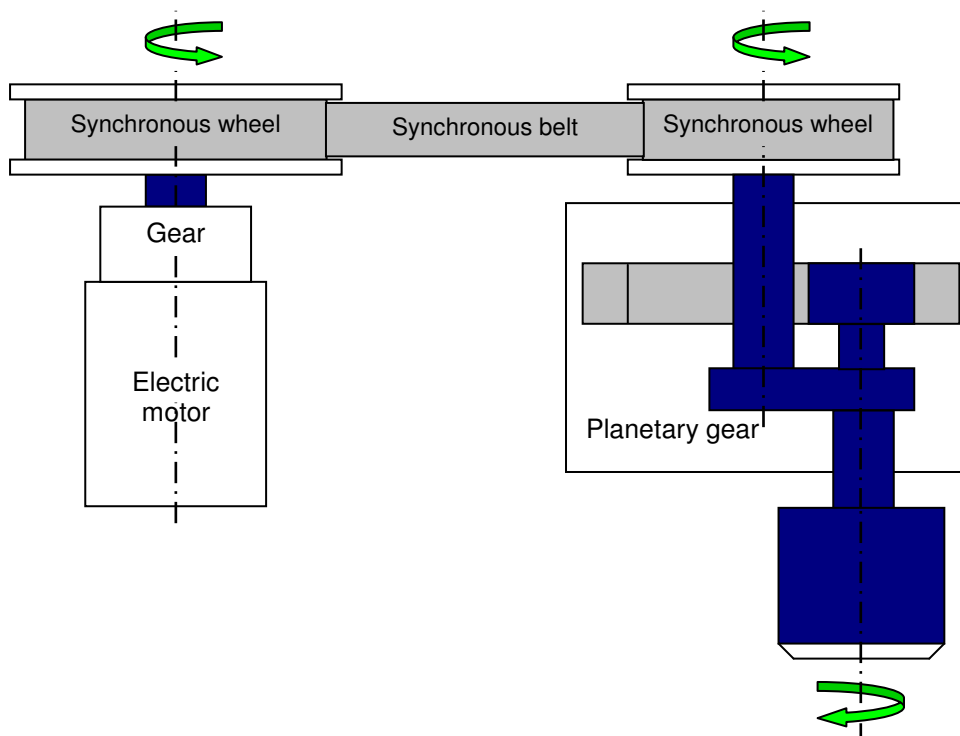

8. Operation of the machine

8.1 Switching on the Laboratory Mortar Mixer

When the Laboratory Mortar Mixer is connected to the mains power, and the main power switch is turned on, the power supply will provide control voltage for the inductive proximity switch for monitoring the status of “**Mixing bowl has been placed in the machine**” and “**Mixing bowl is in mixing position.**” The power supply will also provide control voltage for the operator’s control and monitoring panel.

When the emergency OFF switch has been unlocked, the mixing bowl has been placed in the machine, and it has provided the signal that it is in mixing position, the green signal LED on the operator’s control and monitoring panel will show that the Laboratory Mortar Mixer is ready for operation.





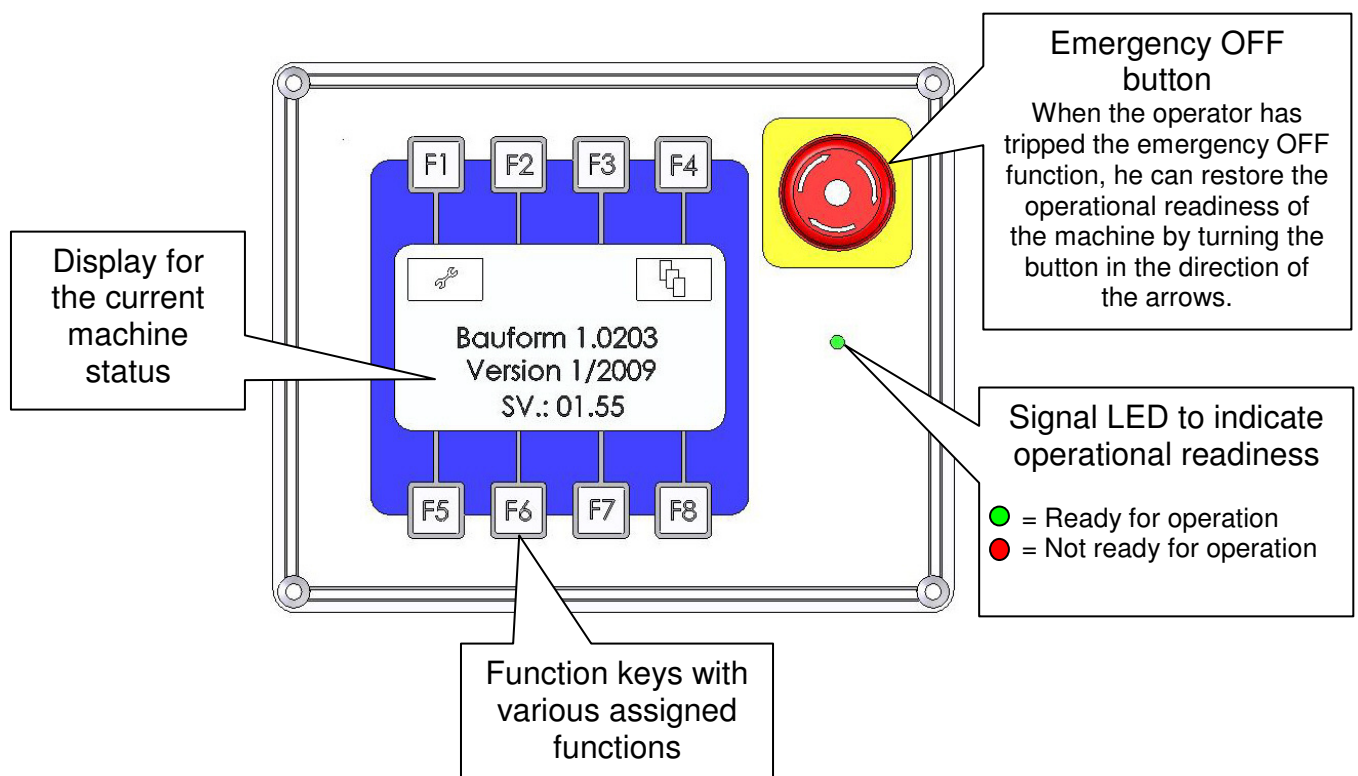





If the emergency OFF switch has been activated, if the mixing bowl has not been placed in the machine, or if it is not in mixing position, the red signal LED will show. In such a case, the display will show instructions for correcting the malfunction (see Section 8.7).

8.2 Description of the operator control unit



Note 	Pressing function key F1 will execute the command shown on the display. Pressing function key F8 will terminate execution of the command shown on the display.
---	--

8.3 Explanation of symbols

Symbol	Function	Description of the function
	Information	These are company and contact details
	Service menu	These are general settings: country language, display brightness, etc.
	Start	This starts the selected function (the time display will also start to run at the same time)
	Stop	This stops the selected function (this also stops the running of the time display)
	Pause	When the pause begins, the time display starts to run to show how much time has run since the pause began.
	Up	This increases the numeric selection by one number.
	Down	This decreases the numeric display by one number.
	Enter	Symbol for confirming an entry.
	Back	Return to the previous menu
	Language selection	The operator can select here among 7 display languages.
	Display brightness	This sets the display brightness.
140/62	140 / 62 rpm	Starts the selected speed of revolution
285/125	285 / 125 rpm	Starts the selected speed of revolution

8.4 Conditions that must be fulfilled before the Laboratory Mortar Mixer will start

1. The mains power supply must be connected, and the direction of rotation must be correct (see Section 6.3 for instructions).
2. The Laboratory Mortar Mixer must have been switched on by the main switch, to the position "I" or "ON".
3. The emergency OFF switch must be unlocked (to unlock this switch, turn the red button in the direction of the arrows).
4. Place the stirrer into its correct position and lock it there (see Section 6.7 for instructions).
5. Place the mixing bowl into its mount and lock it there (see Section 6.8 for instructions)
6. Place the mixing bowl into its proper mixing position (see Section 6.9 for instructions)
7. Use the function keys to control the operation of the Laboratory Mortar Mixer and to call up the required functions, depending on the model (see Sections 8.5 to 8.7 for instructions).

8.5 Display and operator-control unit

Basic settings and contact data

Turn on the Laboratory Mortar Mixer by using the main switch.
Wait briefly (until system data are loaded).

The display will show the start menu shown here (this image is only an example).

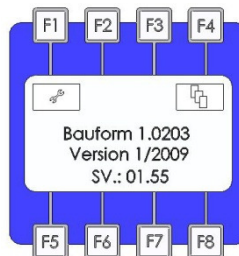

This display will show, for approx. 5 seconds, the model of the Laboratory Mortar Mixer, the version number, and the installed software.

During this period, you can make basic settings by selection key **F1**. You can also view company information and contact data by pressing **F4**. If you make no selection, the display will return to the work menu after about 5 seconds.

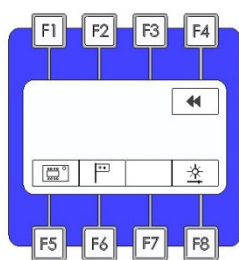
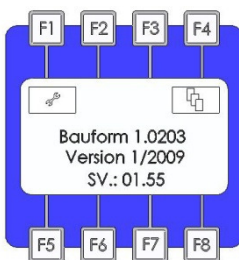
You have selected F1 Basic settings	
Display after selecting F1:	Display after selecting the return key F4:
	
<p>Functions that can be selected:</p> <p>F5 ⇒ Opening possible only with a code (factory setting).</p> <p>F6 ⇒ Selection of language. Here, you can select among 7 different languages: DE / GB / RU / FR / ES / PT / IT.</p> <p>F8 ⇒ Setting the brightness of the display</p> <p>F4 ⇒ Return to the start menu: select F4 by pressing once.</p>	<p>Wait in the start menu for approx. 5 seconds. Then the system automatically moves to the work menu.</p>

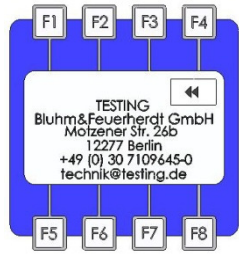
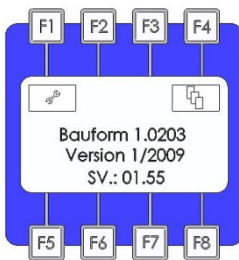
You have selected F4 Company and contact data	
Display after selection of F4	Display after selection of the return key F4
	
<p>F4 ⇒ To return to the start menu, press the return key F4 several times.</p>	<p>Wait in the start menu for approx. 5 seconds. Then the system automatically moves to the work menu.</p>

8.6 Manual operation

<p>Note</p> 	<p>Before starting, fill cement, water, and standard sand into the mixing bowl, in accordance with the standard to be applied.</p>
---	--

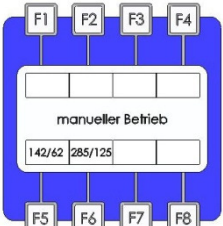
	<p>The display and operator-control unit will now show the work menu shown in this image. You can start the Laboratory Mortar Mixer here by pressing the keys F5 or F6 to select the low (140/62 rpm) or the high (285/125) speeds.</p>
---	---

<p>Caution!</p> 	<p>After you have selected the mixing speed, the Laboratory Mortar Mixer will begin to run immediately.</p>
---	---

<p>Note</p> 	<p>You can switch between the mixing speeds directly, without having to activate the OFF button first.</p>
---	--

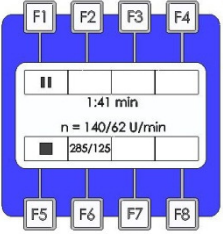
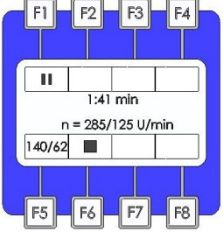
<p>F5 Start with the speed 140/62 rpm</p>	
	<p>Functions for selection:</p> <p>F1 ⇒ Pause (after you press this key, the pause time that has expired, as well as the total run time, will also be shown)</p> <p>F5 ⇒ Stop (this will stop the rotation of the stirrer)</p> <p>F6 ⇒ Selection of 285/125 rpm (the machine will immediately switch to the higher speed).</p>
<p>F6 Start with the speed 285/125 rpm.</p>	
	<p>Functions for selection:</p> <p>F1 ⇒ Pause (after you press this key, the pause time that has expired, as well as the total run time, will also be shown)</p> <p>F6 ⇒ Stop (this will stop the rotation of the stirrer)</p> <p>F5 ⇒ Selection of 140/62 rpm (the machine will immediately switch to the higher speed).</p>

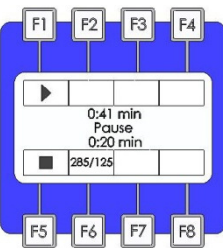

<p>F1 Pause</p>	
	<p>Functions for selection:</p> <p>F1 ⇒ Pressing F1 again will stop the pause, and the machine will immediately start again at the speed 140/62 rpm.</p> <p>F5 ⇒ Pressing F5 will stop the pause the speed that was selected before. <i>The displayed total time will be reset to 0.</i></p> <p>F6 ⇒ This is a pre-selection, and not a start of the machine at speed 285/125. F1 will then start the machine. <i>The total time is now shown again.</i></p>

<p>Note</p> 	<p>You can activate the pause function at both speeds. For example: to allow you to scrape away mortar that has accumulated on the stainless-steel bowl.</p>
---	--

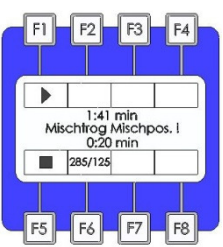
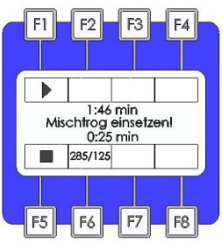
	<p>Note</p> <p>During this pause, you can lower and remove the stainless-steel bowl, without interrupting the total time, which will continue to run.</p>
---	--

Lowering and removing the mixing bowl during the pause	
<p>Display during lowering of the stainless-steel bowl</p>	<p>During lowering of the stainless-steel mixing bowl, the display will show the current total time since the start of a mixing speed, as well as the time that has elapsed after the start of a pause.</p>
	<p>Functions for selection:</p> <p>F1 ⇒ This function stops the pause and immediately starts the mixing speed that was selected before.</p> <p>F5 ⇒ This function stops the pause and the selected speed. <i>This sets the total displayed time back to 0.</i></p> <p>F6 ⇒ This is a pre-selection, and not a start of the machine at speed 285/125. F1 will then start the machine. <i>The total time is now shown again.</i></p>
<p>Display after removal of the stainless-steel mixing bowl</p>	<p>During the lowering and removal of the stainless-steel bowl, the display will show the current total time since the start of a mixing speed, as well as the time that has elapsed after the start of a pause.</p>
	<p>Functions for selection:</p> <p>F1 ⇒ This stops the pause and immediately starts the machine at the previously selected mixing speed.</p> <p>F5 ⇒ This stops the pause and the selected mixing speed. <i>The total mixing time is reset to 0.</i></p> <p>F6 ⇒ This is a pre-selection, and not a start of the machine at speed 285/125. F1 will then start the machine. <i>The total time is now shown again.</i></p>

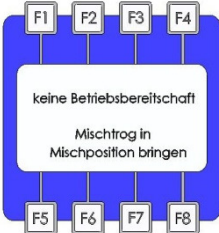
8.7 Error messages

	<p>If the emergency OFF button is pushed, the following message will appear on the operator's control and monitoring panel: “The machine is not ready for operation. Unlock the emergency OFF” You can unlock the emergency OFF by turning the red button in the direction of the arrows. This will also cause the error message to disappear from the display monitor.</p>
	<p>If the mixing bowl is lowered, the following message will appear on the operator's control and monitoring panel: “The machine is not ready for operation. Put mixing bowl in mixing position” When you place the mixing bowl in its mixing position, this will cause the error message to disappear from the display monitor.</p>
	<p>If the mixing bowl is removed from its mount, the following message will appear on the operator's control and monitoring panel: “The machine is not ready for operation. Replace mixing bowl” When the mixing bowl is replaced, this will cause the error message to disappear from the display monitor.</p>

8.8 Switching off the Laboratory Mortar Mixer

When the Laboratory Mortar Mixer is switched off at the main power switch, this will interrupt power voltage to the display, the operator-control unit, and the electrical components (which switches all these components off). If the Laboratory Mortar Mixer is not used for a lengthy period of time, it should be disconnected from the power outlet.

9. Guarantee

The basis for stipulations made in the following is our **General Terms of Sale and Delivery** (*Allgemeine Verkaufs- und Lieferbedingungen*).

The Manufacturer guarantees that this Operating Manual was prepared in conformity with the technical and functional parameters of the product as delivered. The Manufacturer reserves the right to add supplementary information to this Operating Manual.

The Manufacturer grants the legally stipulated guarantee. This guarantee does not cover wear parts.

The Manufacturer guarantees trouble-free operation of this system only if the User properly follows the instructions in this Operating Manual, and only if the User employs this device in accordance with its intended use.

The Manufacturer may not be held liable for any damages which arise from employment of this system which is not in accordance with its intended use, or which arise from the User's failure to follow the instructions and stipulations contained in this Operating Manual.

The Manufacturer shall not be obligated to satisfy any claims under this guarantee in the event that the User makes any structural or component modifications to the product, or if the User modifies the product with respect to its functional state, without the express, prior, and written consent of the Manufacturer.

10. Date of issue of this Operating Manual

Edition no. 3
Date of issue: May of 2010

11. Copyright

The copyright to this Operating Manual remains with the company

TESTING Bluhm & Feuerherdt GmbH

This Operating Manual is intended only for the Operator, User, and the User's staff. The information in this Operating Manual may not be:

- Reproduced, or
- Distributed, or
- Provided to any other persons.

Any person acting in violation of the above stipulations may be prosecuted before a court of law.

12. Address of the manufacturer

TESTING Bluhm & Feuerherdt GmbH
Motzener Str. 26b
D – 12277 Berlin
Germany

Tel. +49 30 710 96 450
Fax: +49 30 710 96 45 98
E-mail: info@testing.de
Internet: www.testing.de

13. Cleaning and maintenance

13.1 Cleaning of the Laboratory Mortar Mixer

If the Laboratory Mortar Mixer is used frequently, or if the ambient conditions are dirty, it will be necessary to clean the outside of the mixer. Proceed as follows:

1. Switch off the main power switch to the position "-0-" or "-OFF-".
2. Disconnect the Laboratory Mortar Mixer from the mains power supply.
3. Use a brush or a vacuum cleaner to clean off loose dust from the surface of the Laboratory Mortar Mixer.
4. If necessary, the outside of the Laboratory Mortar Mixer can be cleaned with a moist cloth. If also necessary, normal household cleaning agents may be used.

<p>Caution!</p> 	<p>Do NOT try to clean the machine with pressurized water, with water spray or other liquid spray, with spray water that results in puddles or dripping sponges, or by any other unsuitable cleaning methods. If any of these methods are used, the water or other liquid that results can enter the control system and lead to permanent damages to the mechanical, electrical, and/or electronic components of the Laboratory Mortar Mixer.</p>
---	--

13.2 Maintenance of the mortar mixer

The Laboratory Mortar Mixer requires practically no maintenance. The cylindrical gears of the 3-phase AC motor, and the planetary gearbox in the head of the stirring mechanism, have been provided at the manufacturer's plant with sufficient lubrication to last for about 5,000 operational hours.

After the Laboratory Mortar Mixer has been in operation for several years, we recommend that it be thoroughly cleaned, and that the gear mechanisms be re-filled with proper lubricant.

Owing to the highly compact design of the Laboratory Mortar Mixer, we recommend having our Maintenance Service perform this work.

13.3 Inspection and adjustment

It is necessary to periodically inspect for the interval between the stirrer and the mixing bowl. The frequency of inspection will depend on how often the Laboratory Mortar Mixer is used. See Sections 6.10 and 6.11 for instructions on how to adjust this interval.

Ordinary wear and tear on the stirrer will cause this interval to increase over time. As a result, adjustment of this interval can become necessary.

13.4 Procedure for shutting down the Laboratory Mortar Mixer for longer periods of time

1. Switch the main switch off: to the position "-0-" or "OFF".
2. Disconnect the Laboratory Mortar Mixer from the mains power supply.
3. Place a dust cover over the entire Laboratory Mortar Mixer.
4. Store the Laboratory Mortar Mixer in a dry room.

Caution!



Safety instructions!

1. Work on electrical equipment may be performed only by qualified specialist staff.
2. In case of malfunction or disassembly of enclosures, turn off the machine and remove the power plug from the mains power outlet.

<p>Note</p> 	<p>Replacement of fuses: In case of malfunction, disconnect the Laboratory Mortar Mixer from the mains power supply. Removal of the upper and lower enclosure panels will provide access to the fusible cut-outs of the individual component assemblies. You can check these fuses in this way. If required, replace them with new, identical fuses.</p> <p>For more detailed troubleshooting and rectification of problems, please consult our detailed description of the control system and the electrical circuit diagrams enclosed with this Operating Manual.</p>
---	--

14. After-sales service and ordering spare parts

Spare-parts list		
Item	Description	Article number
1	Display and operator-control unit	1.0203-09
2	I/O circuit board	1.0203-10
3	Stainless-steel mixing bowl	1.0203.03
4	Stainless-steel stirrer	1.0203.02
5	Slow-blow micro-fuse	EI-0132

If you have any technical questions, or if you require spare parts, please get directly in touch with the following address:

TESTING Bluhm & Feuerherdt GmbH
 Motzener Str. 26b
 D – 12277 Berlin
 Germany

Tel. +49 30 710 96 450
 Fax: +49 30 710 96 45 98
 E-mail: info@testing.de
 Internet: www.testing.de

15. Scrapping the Laboratory Mortar Mixer

To prevent any pollution of the environment, allow your Laboratory Mortar Mixer to be scrapped only by an officially approved disposal specialist company, or by the manufacturer

16. Rear side of the display and operator-control unit

Obzračeno vsehdelno izboljšanje, kar pomeni, da se lahko uporabnik pri uporabi naprave, ki je opremljena s to dokumentacijo, odloži na svoje lastne odgovornosti. Če uporabnik uporablja napravo, ki je opremljena s to dokumentacijo, se šteje za seznanjen s tem, da se lahko uporabnik odloži na svoje lastne odgovornosti.

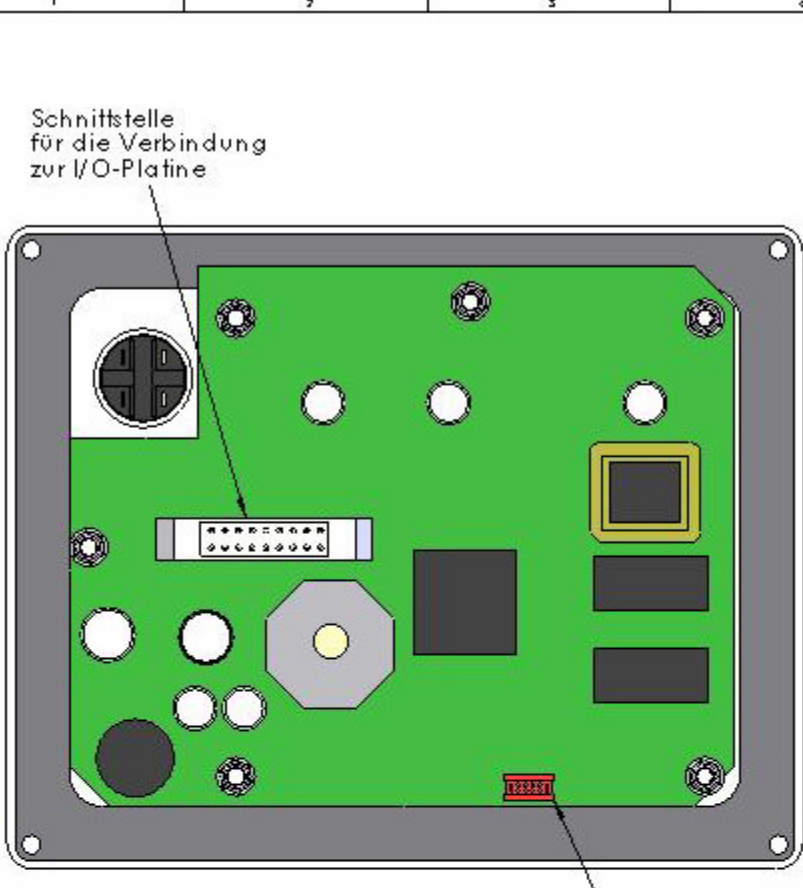

Rev:	Änderung	Datum:	Form:
TESTING Kühn & Neubeck GmbH Maximal Straße 26 b D-12277 Berlin Tel.: +49 30 710 76 43-0 Fax: +49 30 710 76 43-99 e-mail: info@testing.de		Material: 1.1 Bewertungsgruppe: DIN EN 25817 für Schweißverbindung von Stahl : D (gering) Allg.-merkmalen DIN 8570 II für Schweißverbindungen Allg.-merkmalen DIN 60 2168-m II für Längenn- u. Winkelmaß Wertesystemen DIN 6784 großteil	Zeichnung: <h3 style="text-align: center;">Anzeige- und Bedieneinheit</h3>
Gezeichnet:	Datum: 12.05.2010	KAMT	
Gepr.:		J. Petroneck	
Rev:			
Werkstoff:		<input checked="" type="checkbox"/>	
Oberflächenbeschichtung:		<input checked="" type="checkbox"/>	
Gezeichnet:	10421	Zeichnungsnummer: 1.0203-09-01	A4
		Datum: 1.0203-09-01 Anzeige- und Bedieneinheit	Rev: <input checked="" type="checkbox"/> Blatt: <input checked="" type="checkbox"/>

17. I/O circuit board

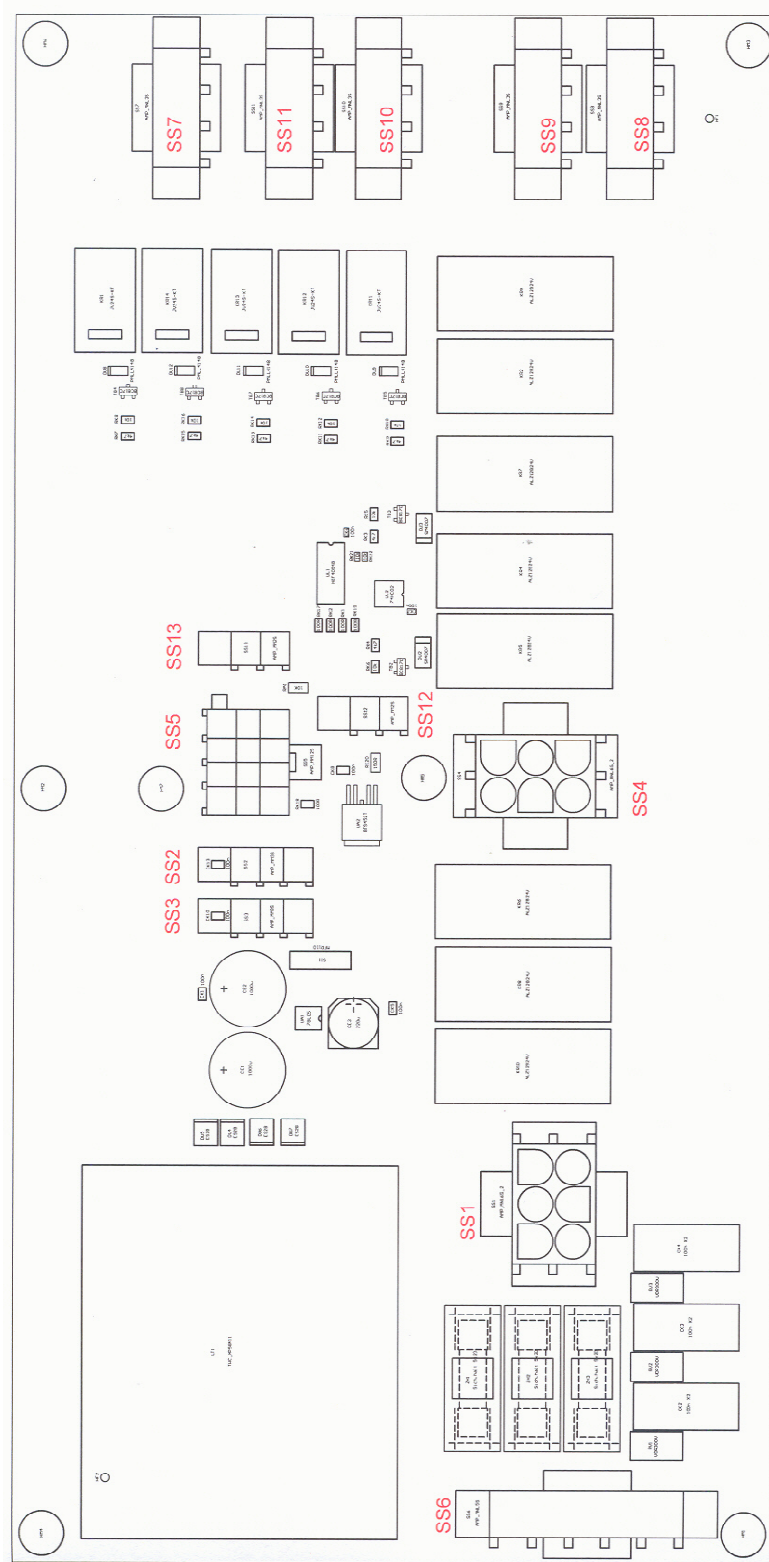

SS1 = ext. NOT-STOP-Relais	SS7 = Relaisausgang potentialfrei
SS2 = Mischtrog	SS8 = Sandzulauf
SS9 = Mischtrogposition	SS9 = Wasserpumpe
SS4 = Motor	SS10 = Wasserzulauf
SS5 = Schnittstelle IO/Platine	SS11 = Absaugung
SS6 = Einspeisung 400 Volt	SS12 = Wasserdosierung

EG – Declaration of Conformity
In accordance with EG Machinery Directive 2006/42/EG, Annex II 1.A

The manufacturer / supplier:

TESTING Bluhm & Feuerherdt GmbH
Motzener Str. 26b
D – 12277 Berlin, Germany

hereby declares that the following product —

Product designation: Laboratory Mortar Mixer
Model: TESTING
Serial number: consecutive
Serial / type designations: 1.0203

— conforms to all the relevant stipulations of the above-stated Directive, as well as of the further applied Directives (listed below), including the modifications to these stipulations valid at the date of this Declaration.

The following further EU Directives have been applied:

Directive 2004/108/EG on Electromagnetic Compatibility
Directive 2006/95/EG on Low-Voltage Equipment

The following harmonized standards have been applied:

- EN 12151:2007 Machines and Facilities for the Preparation of Concrete and Mortar – Safety Regulations
- EN 349:1993+A1:2008 Safety in Working with Machines: Minimal Intervals to Prevent Crushing of Bodily Parts
- EN ISO 12100-1:2003 Safety in Working with Machines: Basic Terms, General Design Principles – Part 1: Basic Terminology and Methodology (ISO ISO 12100-1:2003)
- EN ISO 12100-2:2003 Safety in Working with Machines: Basic Terms, General Design Principles – Part 2: Technical Principles (ISO 12100-2:2003)
- EN ISO 14121-1:2007 Safety in Working with Machines – Assessment of Risks – Part 1: Principles (ISO 14121-1:2007)

The following national or international standards (or sections or clauses therefrom) and specifications were applied:
—

Name and address of the person who is authorized to compile the technical documentation: Jens Petraneck.

Place: TESTING, Berlin, Germany
Datum: 12 May 2010

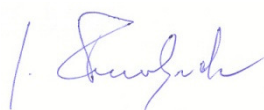

(Signature):
Joachim Feuerherdt CEO



(Signature):
Jens Petraneck, Production Manager

<h2 style="margin: 0;">Test Report</h2> <p style="margin: 0;">For final acceptance of the Laboratory Mortar Mixer Model: 1.0203</p>	
<p>Mechanical test criteria:</p> <ol style="list-style-type: none"> 1. Mechanism for raising the mixing bowl 2. Seating of the mixing bowl 3. Interval between stirrer and mixing bowl (3 ± 1 mm) 4. Seating of the stirrer in the eccentric clamp 5. Low-speed planetary movement (required: 62 ± 5 rpm) 7. High-speed planetary movement (required: 125 ± 10 rpm) <p>Electrical test criteria</p> <ol style="list-style-type: none"> 1. Software version 2. Main power switch 3. Functional test for manual operator control 4. Functional test for automatic control 5. Information retrieval: "Mixing bowl in place" 6. Information retrieval: "Mixing bowl in mixing position" 7. Function: emergency OFF <p>Visual inspection</p> <ol style="list-style-type: none"> 1. Clean painted and switch surfaces 2. Proper assembly of the operator-control elements <p>Final functional test</p>	<div style="margin-bottom: 10px;"><input style="width: 100%;" type="text" value="OK"/></div> <div style="margin-bottom: 10px;"><input style="width: 100%;" type="text" value="OK"/></div> <div style="margin-bottom: 10px;"><input style="width: 100%;" type="text" value="OK"/></div> <div style="margin-bottom: 10px;"><input style="width: 100%;" type="text" value="OK"/></div> <div style="margin-bottom: 10px;"><input style="width: 100%;" type="text"/></div> <div style="margin-bottom: 10px;"><input style="width: 100%;" type="text"/></div> <div style="margin-bottom: 10px;"><input style="width: 100%;" type="text" value="SV:"/></div> <div style="margin-bottom: 10px;"><input style="width: 100%;" type="text" value="OK"/></div> <div style="margin-bottom: 10px;"><input style="width: 100%;" type="text" value="OK"/></div> <div style="margin-bottom: 10px;"><input style="width: 100%;" type="text" value="OK"/></div> <div style="margin-bottom: 10px;"><input style="width: 100%;" type="text" value="OK"/></div> <div style="margin-bottom: 10px;"><input style="width: 100%;" type="text" value="OK"/></div> <div style="margin-bottom: 10px;"><input style="width: 100%;" type="text" value="OK"/></div> <div style="margin-bottom: 10px;"><input style="width: 100%;" type="text" value="OK"/></div> <div style="margin-bottom: 10px;"><input style="width: 100%;" type="text" value="OK"/></div> <div style="margin-bottom: 10px;"><input style="width: 100%;" type="text" value="OK"/></div>
<p>Mixer type: <u>1.0203</u></p> <p>Unit no. <u>509</u></p> <p>Test date: _____</p> <p>In charge of testing: _____</p>	

<h2 style="margin: 0;">Record of Measurement and Testing</h2> <p style="margin: 0;">DIN VDE 57 100 - VDE 0701 BGV A3</p>
--

<input type="checkbox"/>	Acceptance testing	<input type="checkbox"/>	Testing after a repair
--------------------------	--------------------	--------------------------	------------------------

Model / Type	Article number	Production number
Mortar Mixer	1.0203	509 - 2013

Ratings					
Voltage	Frequency	Current	Power	Speed	Class of protection
400 V	50 Hz	1,5 A	0.4 kW	62/125 rpm	I (VDE 0100)

No.	Test or measurement	REQUIRED	ACTUAL
1	Visual check for protective earth conductor / equipotential bonding		<input type="checkbox"/> <input type="checkbox"/> OK
2	Supply voltage during the measurement		V
3	Contact resistance test	< 300 mΩ	mΩ
4	Insulation resistance	≥ 1.0 MΩ	MΩ
5	Equivalent device leakage current	≤ 3.5 mA	mA
6			
7			
8			
9	Functional test		<input type="checkbox"/> OK

Measuring equipment used:	Digital multimeter (Voltcraft)	Equipment tester as per 0701
---------------------------	--------------------------------	------------------------------

Results of repair / spare parts required / remarks:

Important notes:

- A We recommend the use of a residual-current circuit-breaker (RCCB) with fault-current tripping rating of 30 mA.
- B For movable electrical equipment, the German Accident-Prevention Regulations, requires that measurements according to VDE 0701, Sections 1 – 4, be repeated at intervals of approx. every six (6) months. As manufacturer of such equipment, we are required to inform you of this regulation.

Measurements and tests conducted on:	Date:	Signature:
--------------------------------------	-------	------------