

**Voluvessel**

This unit has been calibrated and is ready for use as received.

After set-up, calibration is recommended.

Calibration Check:

Verify the procedure to be used and the accuracy of the volume indicator by using the apparatus to measure containers or molds of determinable volume that dimensionally simulate test holes that will be used in the field. The apparatus and procedure shall be such that these volumes will be measured to within 1.0 percent. Containers of different volumes shall be used so that calibration of the volume indicator covers the range of anticipated test hole sizes.

Note: The H- 4141 four-inch mold and the H-4161 six-inch mold described in ASTM D698 and D1557 test for moisture/density relations of soils or other molds prepared to simulate actual test holes may be used. Where several sets of apparatus are used, it may be desirable to cast duplicates of actual test holes. These sets should represent the range of sizes and irregularities in the walls of the test holes that will be encountered. These fabricated holes can be used as standards for the calibration check of the Volu vessel. This can be accomplished by forming plaster of Paris negatives in the test holes and using these forms as forms for Portland cement concrete castings, after removing the plaster of Paris negative from the concrete castings, the inside surface of the fabricated holes should be sealed watertight, and their volume determined as indicated.

Method to obtain volume of container or mold to be used to check the accuracy of the volu vessel:

Determine the mass of water, in grams, required to fill one of the containers. Slide a glass plate carefully over the top of the surface of the container in such a manner as to ensure the container is filled completely with water. Determine the temperature of the water in the container. A thin film of cup grease smeared on the top surface of the container will make a watertight joint between the glass plate and the top of the container. Calculate the volume of the container in cubic feet (or cubic meters) by multiplying the mass of the water, in grams used to fill the container by the unit volume of water, in milliliters per gram, at the observed temperature taken from Table 1, and dividing the result by 28317 ml/ft³ (or 1×10^6 ml/m³). Repeat this procedure until three values are secured for the volume of the container having a maximum range of variation 0.0001 ft³ or (2.8 x 10⁻⁵) m³, Repeat this procedure for each of the containers to be used in the calibration check.

Calibration check tests

Place the rubber-balloon apparatus on a relatively smooth horizontal surface. Pressurize it to 5psi and then adjust the water level up or down until it's at zero on the scale. Transfer the apparatus to one of the containers and take the reading on the volume indicator when the rubber balloon completely fills the container (Notes 1 & 2).

Apply pressure to the liquid in the apparatus until there is no change indicated,

on the volume indicator. Note and record the pressure. Depending upon the type of apparatus, this pressure may be as high as 5 psi (34.5 kPA). It will usually be necessary to add load (surcharge) to the apparatus to prevent it from rising (Note 3). Note and record the total amount of load added. The difference between the initial and the final readings of the volume indicator is the indicator volume value for the container.

The membrane may be withdrawn from the container by applying a partial vacuum to the liquid in the apparatus. Repeat the procedure for the other containers.

Note 1:

If the calibration container or mold is airtight, it may be necessary to provide an air escape, since the rubber membrane can entrap air within the container and cause an erroneous volume measurement. After the volume of the container has been determined with water and prior to the insertion of the rubber balloon, small air escape holes may be provided by placing lengths of small diameter string over the edge of the container and down inside the wall slightly beyond the bottom center. This will permit air leakage during the filling of the container with the membrane. If such a procedure is necessary in the laboratory, it may be necessary to use a similar procedure on tightly-bonded soil in the field.

Note 2:

Before any measurements are made, it may be necessary to distend the rubber balloon and remove air bubbles adhering to the inside of the membrane by kneading.

Note 3:

In field tests, additional loads (surcharge) will increase the stress in the unsupported soil surrounding the test hole and will tend to cause it to deform. Using a base plate may reduce the stress.

Table 1: Volume of water per gram based on Temperature

°C	°F	Water Volume ml/g
12	53.6	1.00048
14	57.2	1.00073
16	60.6	1.00103
18	64.4	1.00138
20	68	1.00177
22	71.6	1.00221
24	75.2	1.00268
26	78.8	1.0032
28	82.4	1.00375
30	86	1.00435
32	89.6	1.00497

Values other than show may be obtained by referring to:
 Handbook of Chemistry and Physics
 Chemical Rubber Publishing Co.
 Cleveland, Ohio

Table 2: Maximum Field Test Hole Volumes and
 Minimum Moisture Content Samples
 based on Maximum Size of Particle

Maximum Particle Size	Minimum Test Hole Volume ft ³ (m ³)	Water Volume ml/g
No.4 (4.75mm)	0.025 (0.0007)	100
1/2" (12.5mm)	0.050 (0.0014)	250
1" (25mm)	0.075 (0.0021)	500
2" (50mm)	0.100 (0.0028)	1000
2-1/2" (63mm)	0.135 (0.0038)	1500

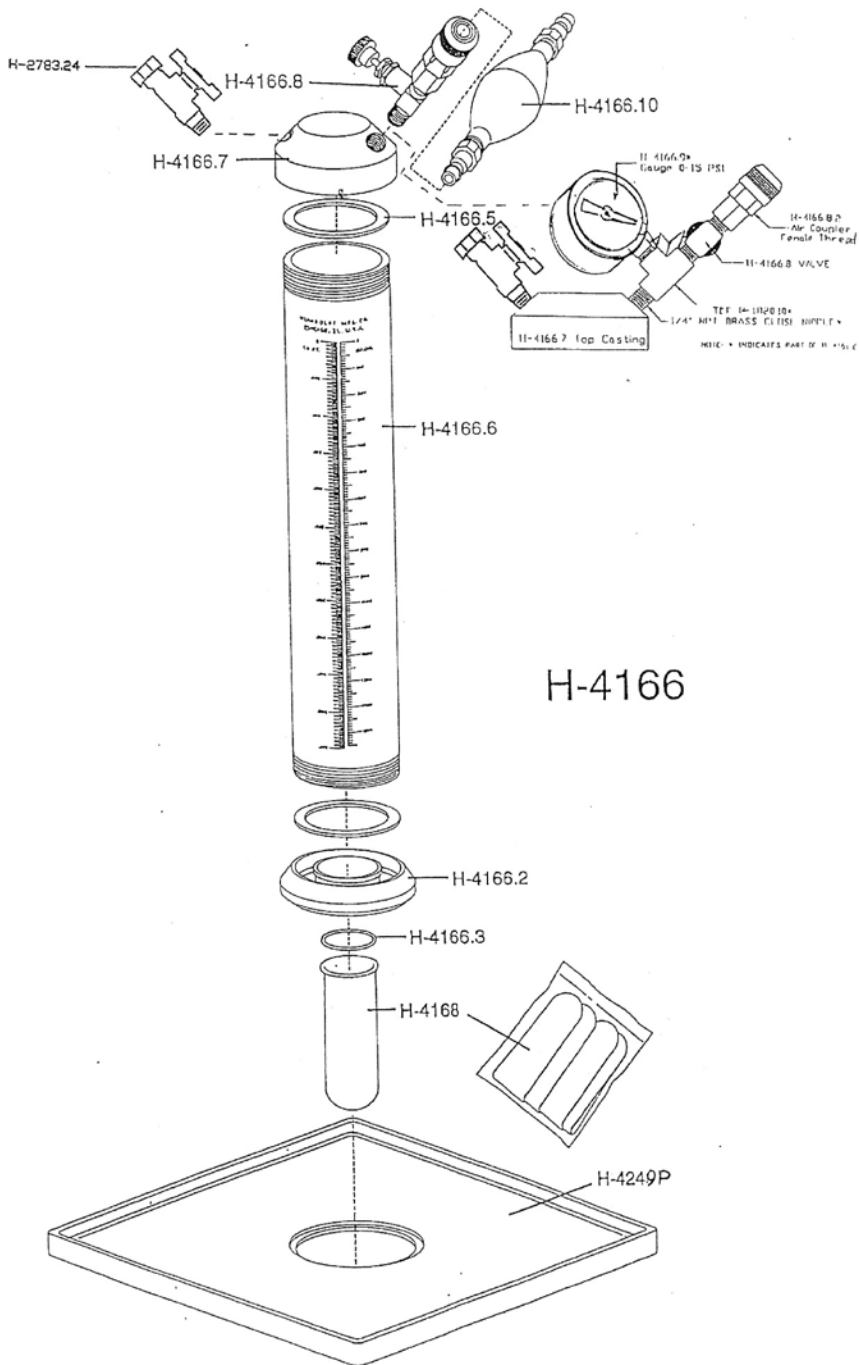

Warranty

Humboldt Mfg. Co. warrants its products to be free from defects in material or workmanship. The exclusive remedy for this warranty is Humboldt Mfg. Co., factory replacement of any part or parts of such product, for the warranty of this product please refer to Humboldt Mfg. Co. catalog on Terms and Conditions of Sale. The purchaser is responsible for the transportation charges. Humboldt Mfg. Co. shall not be responsible under this warranty if the goods have been improperly maintained, installed, operated or the goods have been altered or modified so as to adversely affect the operation, use performance or durability or so as to change their intended use. The Humboldt Mfg. Co. liability under the warranty contained in this clause is limited to the repair or replacement of defective goods and making good, defective workmanship.

Humboldt Mfg. Co.

875 Tollgate Road
Elgin, Illinois 60123 U.S.A.

U.S.A. Toll Free: 1.800.544.7220

Voice: 1.708.456.6300

Fax: 1.708.456.0137

Email: hmc@humboldtmfg.com

Testing Equipment for



Construction Materials

HUMBOLDT

www.humboldtmfg.com