



Rapid Soil Processor

Introduction

Compact all-metal soil processor allows customer to produce five-point moisture density relationship test results in about 5 hours. Processor also handles samples for rapid compaction of a family of curves test. Processes up to 30 lbs. of lean-to-fat and tough clays at field moisture in fewer than 15 minutes. Automatically separates and retains up to 3/4" rocks from soil to prolong screen life. Processes soil to pass a No. 4 screen. Offset rotating drum is motor driven; pre-set adjustments aren't necessary. Automatic operation frees up technician's time. Order easy-to-install replacement screen separately. Replacement parts are available. Overall dimensions: 32 x 36 x 53" (813 x 915 x 1346mm). Shipping wt. 408 lbs. (184kg)

Operation

The Rapid Soil Processor was designed and constructed to process **Field Sample Moist Soil Only**. After the material has been processed, it can be rerun regardless of moisture content; this is beneficial to reduce drying time or produce smaller particles to absorb moisture. This machine can be used to blend various types of soil regardless of moisture content but attempting to process dry chunks could damage the screen and the machine.

DO NOT ATTEMPT TO TEST LARGER THAN 3/4 INCH AGGREGATE.

The **Rapid Soil Processor** is designed to process moist soils containing aggregates up to 3/4 inch diameter maximum. The machine is constructed to accommodate 14-gauge screens. This is determined by the type of material and the amount of gravel in the material to be processed.

Safety

1. **CAUTION:** The machine has 2,325 ft. lbs. of torque on the drum shaft.
2. The Guard over the drum gear and chain should be in a closed position when the machine is in operation. It is easily raised for cleaning and loading the machine.
3. The machine is equipped with three switches. Switch #1 on the arm of the pressure plate automatically shuts the switch off before pressure damages the screen or drum. Switch #2 is manually operated to control the machine at any time and position. Switch 3 on the safety guard must be closed for the processor to operate.
4. **DRY MATERIAL OR MATERIAL CONTAINING AGGREGATE OVER 3/4 INCH SHOULD NOT BE PROCESSED.**
5. The **Spring Tension on the Pressure Plate**, which releases gravel without damaging the screen is **Pre-Set** and should not be changed.
6. The Weight on the Pressure Plate Arm has been pre-determined and should be sufficient to move material into the screen.

Operating Instructions

1. Be sure that the **Automatic Kill Switch** (H-4215.50) is properly set before starting the machine.
2. Detach weight from the **Pressure Plate Arm** (H-4215.3.4).
3. Release **Catch** (H-4215.3.12) on the Pressure Plate Guide and open the material container space.
4. Be sure the **Guard**, (H-4215.9), is in place.
5. Both **Switches** (H-4215.50.1), must be correctly set to start the test. The yellow guard switch has to be closed and the pressure plate switch has to be open.
6. Fill the machine with material to be processed. When full, attach the weight to the pressure plate arm.
7. On some impervious materials, the cut face of the material will appear glazed slowing the cutting process. Stop the machine and break up the material. Resume operation.
8. If gravel accumulates on the face of the material, stop the machine, open the pressure plate, and remove the rock.

Maintenance

1. The **Pillow Block Bearings** on the drum should be greased once every six months. Be careful not to blow the grease seals on the bearings.
2. Do not oil the chain drive. Check periodically for slack in the chain-keep the chain tight.
3. Check oil level in the gear box every six months.
4. All **Bearings** are stock items in most localities and can be replaced with a minimum of down time.
5. To change the screen see the "Screen Replacement Procedure".
6. Pre-shaped **Screens** (H-4215.32) may be ordered from Humboldt.

Unit Cleaning

1. Release **Pressure Plate** (H-4215.3 and H-4215.3.12), and bring to open position; by lifting out the **Pressure Plate** (H-4215.3.4), the machine will open, exposing the inside of the **Pressure Plate, Plate Guide, Screen and Table Top**.
2. The **Cleaning Attachment** on the back side, will help clean the **Screen** by letting the machine run a short time while it is empty.
3. Tools used in cleaning the machine are a **Wire Brush, Rubber Mallet, Bristle Brush, Spatula** and **Knife**.

4. If the machine is not used constantly, let the material dry on the screen. Then start the machine and tap the screen with the rubber mallet.
5. Wipe all parts which come in contact with the processed material, with a damp cloth containing light oil. This will prevent the material from sticking but will not affect the test results.

Accessory Parts for Screen Replacement

- (6) 114-20 Flat head screen-retaining screws and nuts.
- (4) 114" Hex-head screen-retaining strip screws.
- (1) Screen: H-4215.32

Screen Replacement Procedure

Note: The drum should be aligned with screen towards the front of the machine. Should it become necessary to rotate the drum during the following procedure, be sure the machine is turned **Off** and **Unplugged** prior to continuing

1. Remove retaining strip on top of drum.
2. Remove 114-20 screen-retaining screws (six pieces) and lock washers.
3. Remove the old screen and replace it with new.
4. Replace six 1/4-20 flat head screen retaining screws.
5. Replace retaining strip on top of drum.

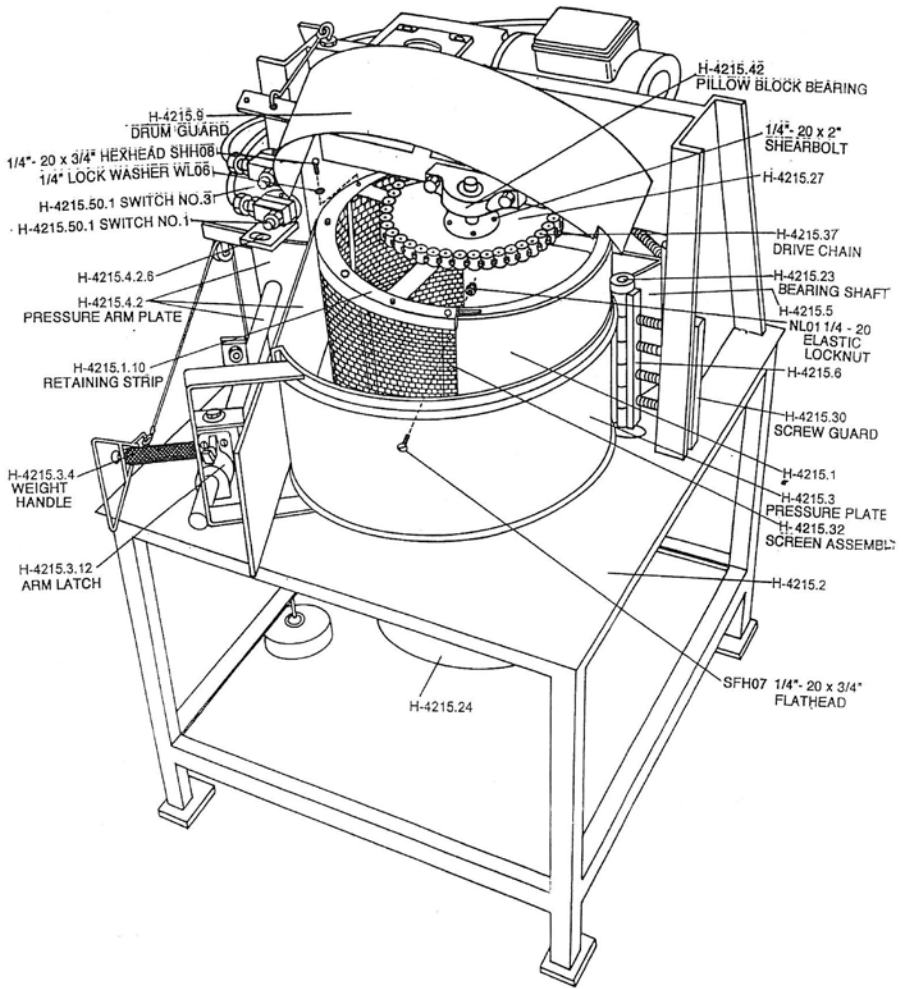

H-4215 Parts

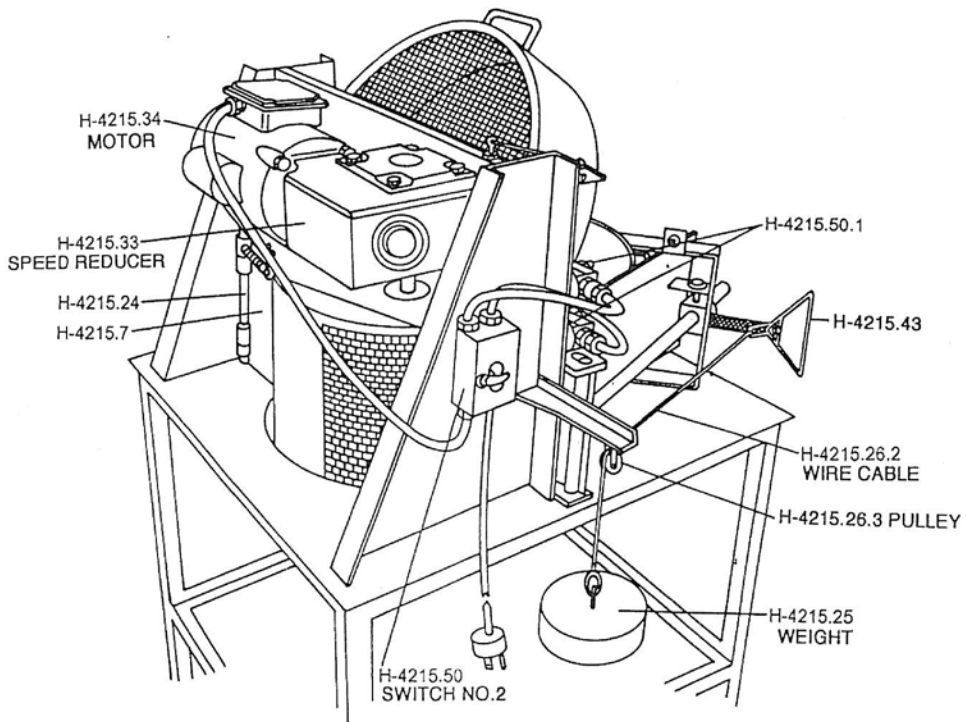

H-4215 Additional Parts

Warranty

Humboldt Mfg. Co. warrants its products to be free from defects in material or workmanship. The exclusive remedy for this warranty is Humboldt Mfg. Co., factory replacement of any part or parts of such product, for the warranty of this product please refer to Humboldt Mfg. Co. catalog on Terms and Conditions of Sale. The purchaser is responsible for the transportation charges. Humboldt Mfg. Co. shall not be responsible under this warranty if the goods have been improperly maintained, installed, operated or the goods have been altered or modified so as to adversely affect the operation, use performance or durability or so as to change their intended use. The Humboldt Mfg. Co. liability under the warranty contained in this clause is limited to the repair or replacement of defective goods and making good, defective workmanship.

Humboldt Mfg. Co.

875 Tollgate Road
Elgin, Illinois 60123 U.S.A.

U.S.A. Toll Free: 1.800.544.7220

Voice: 1.708.456.6300

Fax: 1.708.456.0137

Email: hmc@humboldtmfg.com

Testing Equipment for



Construction Materials

HUMBOLDT

www.humboldtmfg.com