

product manual 07.17

H-4219T  
H-4219QC

# Dual-Mass, Dynamic Cone Penetrometer

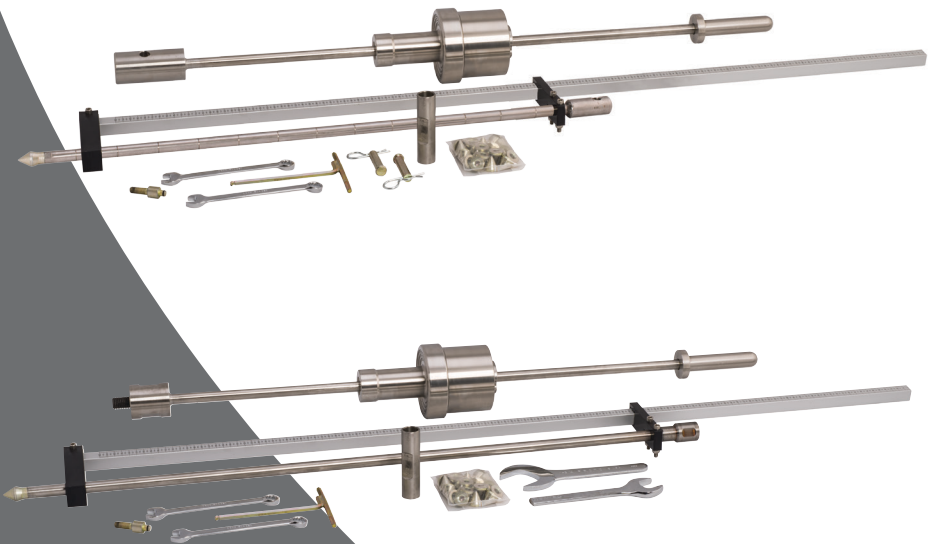



<b>Quick Start Guide</b>	<b>4</b>
Unpacking	
<b>Assembly</b>	<b>4</b>
<b>Safety Precautions</b>	<b>4</b>
<b>DM-DCP Parts Drawing (Figure #1)</b>	<b>5</b>
<b>Pre-Test Check</b>	<b>6</b>
Pre-Test Check — Drive Rod	6
Pre-Test Check — Hard Cone Tip	6
Pre-Test Check — Disposable Cone	6
<b>Test Methods</b>	<b>6</b>
One-Person Method	6
Two-Person Method	7
Penetration	8
Disposable Cone Tips	8
Rejection	9
Extraction	9
<b>Special Applications</b>	<b>9</b>
Below Bound Layers or Pavement	10
Pavement with Thin Seals	10
<b>Data Recording and Tabulation</b>	<b>11</b>
DM-DCP Data Form	12
Tabulated Correlation of CBR	13
<b>Data Correlations</b>	<b>14</b>
Example	14
Excel Template	14
Excel Template Instructions	15
<b>Maintenance</b>	<b>16</b>
<b>DM-DCP Overview</b>	<b>17</b>
<b>H-4219T Parts List</b>	<b>19</b>
<b>H-4219QC Parts List</b>	<b>20</b>
<b>Dual-Mass DCP Accessories</b>	<b>21</b>

**Unpacking**

Initial inspection should include checking for physical damage during shipping and obvious external damage to the product.

**Assembly****DM-DCP (Dual-Mass Dynamic Cone Penetrometer)  
Assembly (Figure 1)**

To begin assembly of the DM-DCP, attach the Drive Rod, which should already have the Upper Scale Guide attached to it, to the Upper Drive Rod. In the case of the H-4219T this would involve screwing the two items together using the wrenches provided. In the case of the H-4219QC, the two items would be attached with the help of the Quick-Connect Pin.

Next slide the Scale, which should already have the Scale Guide Foot attached, up through the Upper Scale Guide, allowing the Drive Rod with the Hard-Tipped Cone or Re-usable Cone attached to slide through the hole in the Scale Guide Foot.

Once this has been completed, you are ready to perform a test.

**Safety Precautions**

It is recommended that when using the DM-DCP that you wear safety glasses and gloves. Also, be cautious when raising and dropping the hammer and keep fingers away from any pinch points.

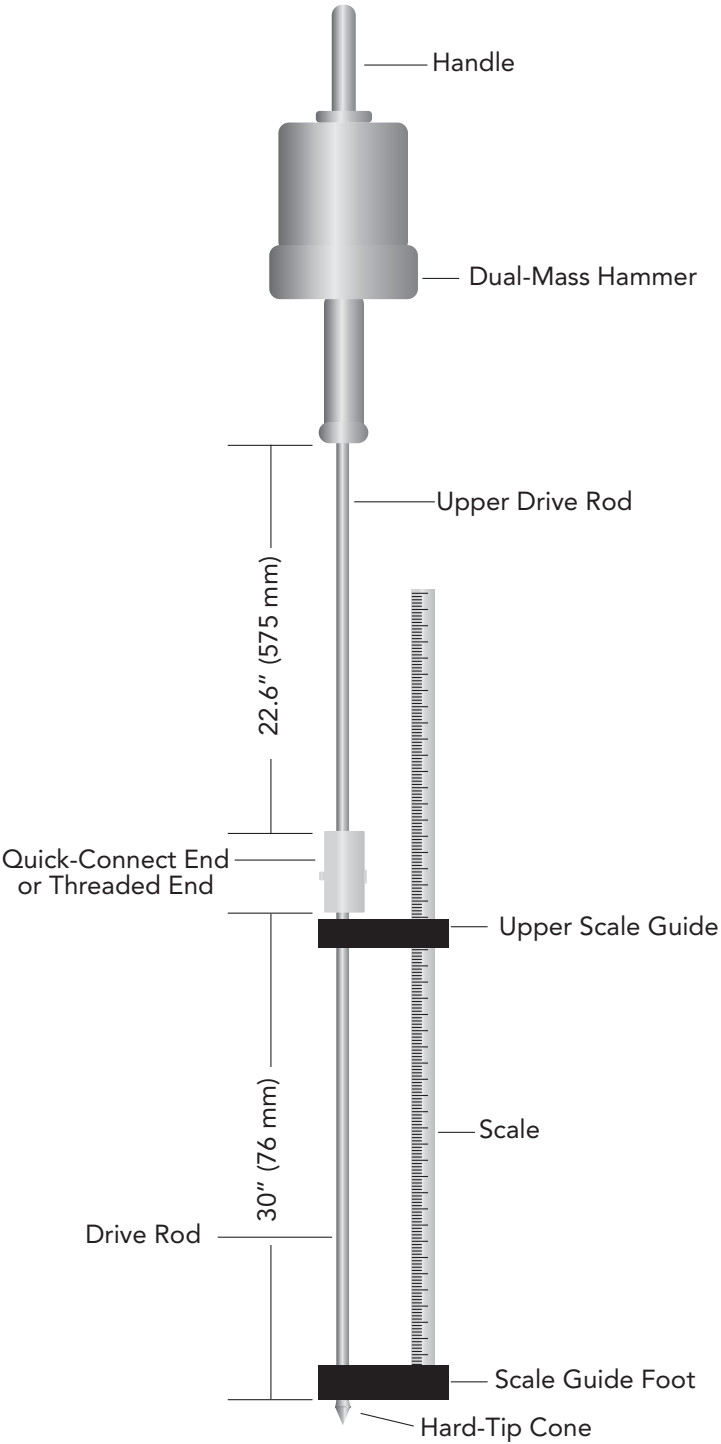

Figure #1

## Pre-Test Check

### Pre-Test Check— Drive Rod

Before proceeding with an actual test, inspect the drive rod and make sure it is straight. This can be achieved by rolling the rod and a flat surface. If the drive rod is bent, it should be replaced and not be used. A typical cause of bent drive rods would include continuing to drive the rod beyond the point of refusal.

### Pre-Test Check— Hard Cone Tip

The hard cone tip should be checked to ensure that the 3mm flat is discernable. This flat area will have a tendency to become rounded, and when this happens the cone tip should be replaced. This typically occurs after about 250 tests. Rarely, if ever, does the hard cone tip wear enough where the diameter fails to meet specifications. However, this can be checked with the included go/no-go gauge.

### Pre-Test Check— Disposable Cone Adapter

Check to ensure that the o-ring on the disposable cone adapter is clean, fits snugly and shows no signs of knicks or cuts. To replace it, order H-4219.5.1

## Test Methods

Because Humboldt's DM-DCPs utilize a mounted distance scale, they can be operated by a single person or they can be operated by the traditional two person method.

### One-Person Method

For one-person operation, it is suggested to place blue, removable painters' tape along the side of the distance scale to aid in the marking of the position of the drive rod as it is hammered into the ground.

To begin, hold the DM-DCP in an upright position as close to perpendicular to the ground as possible. Lightly, use the hammer to push the cone into the ground **until the widest part of the tip is flush with the surface** of the material to be tested. Mark this position on the tape. The accuracy of this measurement should be to the nearest 0.04" (1mm). This is your starting position and you are now ready to start the testing procedure.

Holding the DM-DCP in a vertical position, raise the hammer until it touches, but does not impact, the handle. From this position let the hammer free-fall so it impacts the anvil/coupler assembly. Care should be exercised when raising the hammer to ensure that the hammer is touching the bottom of the handle but not lifting the cone before it is allowed to drop. The hammer must be allowed to fall freely with its downward movement not influenced by any hand movement. The operator should also be careful not to exert any downward force on the handle after dropping the hammer. Also, try to maintain a rigid vertical position during the test and avoid rocking the unit back and forth.

Continue to drop the weight until you have driven the drive rod and cone a distance of about 1" (25mm) and, using a marker, mark the location on the tape, using the top guide bracket as a marking point. Some methods call for marking the driven depth at 2" (50mm) increments. When you mark the distance on the tape, also mark how many hammer drops were required to achieve this mark.

Continue this process until you have reached your desired testing depth.

### Two-Person Method

For two-person operation, one person operates the DM-DCP and the other person records the position and number of blows. This can be done like the one-person method, using blue painters' tape and a marker, or the second person can actually record the distance and blows directly.

To begin, hold the DM-DCP in an upright position as close to perpendicular to the ground as possible. Lightly, use the hammer to push the cone into the ground **until the widest part of the tip is flush with the surface** of the material to be tested. Either mark this position on the tape or record the position. The accuracy of this measurement should be to the nearest 0.04" (1mm). This is your starting position and you are now ready to start the testing procedure.

Holding the DM-DCP in a vertical position, raise the hammer until it touches, but does not impact, the handle. From this position let the hammer free-fall so it impacts the anvil/coupler assembly. Care should be exercised when raising the hammer to ensure that the hammer is touching the bottom

of the handle but not lifting the cone before it is allowed to drop. The hammer must be allowed to fall freely with its downward movement not influenced by any hand movement. The operator should also be careful not to exert any downward force on the handle after dropping the hammer. Also, try to maintain a rigid vertical position during the test and avoid rocking the unit back and forth.

Continue to drop the weight until you have driven the drive rod and cone a distance of about 1" (25mm). The second person will then either mark the location on the tape using the top guide bracket as a marking point or simply record the distance and the number of hammer drops required. Some methods call for marking the driven depth at 2" (50mm) increments.

Continue this process until you have reached your desired testing depth.

### **Penetration**

Penetration measurements should be recorded to the nearest millimeter. The cone should penetrate a minimum of 1" (25mm) between recorded measurements. The penetration to the nearest 0.04" (1mm) corresponding to the specific number of blows is recorded. A reading should be taken immediately when material properties or rate of advance of the cone change significantly.

The depth of penetration will vary with application. For typical highway applications, a penetration of less than 30" (750mm) will generally be adequate.

With both methods operators should be alert to a sudden increase in the cone penetration rates during the test. Any noticeable increase in the penetration rate indicates a weaker soil layer.

### **Disposable Cone Tips**

The disposable cone tip is usually used in soils where the standard cone becomes difficult to remove. The disposable cone tip mounts on the extension shaft assembly equipped with the cone tip adaptor. At the conclusion of the test, the disposable cone easily slides off the cone tip adaptor allowing the operator to quickly remove the DM-DCP device from the soil. The disposable cone tip remains in the soil. Use of the disposable cones can approximately double the num-



ber of tests that can be run per day. It also helps to greatly reduce user fatigue, as well as excess wear and tear on the DM-DCP Slide Hammer Assembly.

### **Rejection**

Rejection occurs when the DM-DCP can not be advanced into the soil or that advancement has slowed to a negligible amount. Continuing to drop the hammer in this situation risks damaging the instrument. Usually, this is caused by the presence of aggregates > 2" or rock strata. If, after 5 blows, the device has not advanced more than 0.08" (2mm) or the handle has deflected more than 3" (75mm) from the vertical position, the test should be terminated and another location selected.

### **Extraction**

If using the solid cone and after the cone has been driven to the desired test depth (max. 1m), it will need to be extracted from the soil by driving the hammer up against the handle. Caution must be exercised during this operation in order to not damage the DM-DCP device or pinch the operator's hand.

The hammer must be raised in a vertical direction, rather than in a arcing motion, or the rod may be bent or broken. In soils where great difficulty is encountered in extracting the device, the disposable cone tips should be used. Use of the disposable cone tips will save wear and tear on both the device and the operator.

In some soils with large aggregate, the DM-DCP may try to penetrate the soil at a slant rather than from the desired vertical direction. The operator should not apply force to the handle of the DM-DCP in an attempt to force it to penetrate the soil vertically. Lateral force will cause the upper handle rod to fatigue and possibly break. Instead, the test should be stopped when the handle deviates laterally 6" (150mm) or more from the vertical position and a new test attempted at another location.

## **Special Applications**

### **Extended Depth Testing**

There are several available methods for using the DM-DCP at extended depths. The first method would be the use of Extension Rods. Extension rods are 24" in length and can

be combined for depths up to 6'. When using extension rods it is suggested that you purchase the 12" Drive Road (H-4219T.12 or H-4219QC.12). This allows you to work with the extensions without needing a ladder to begin testing with each added extension rod. In use, you would replace the original drive rod with the 12" model and add a 24" extension rod to it. Once you have driven the first 24" extension into the material being tested, stop and add another extension and then continue the test. This process can be accommodate up to a total of 3 extensions. Extended depths can be accomplished by beginning your testing from a trench location or by using an auger or earth drill to get past the first layers of material.

### **Below Bound Layers or Pavement Testing**

The first step in this scenario would be to utilize a rotary hammer drill or a coring apparatus capable of making an access hole large enough for the extension rods to fit through, which would be at least 1" (25mm) or larger depending on the application.

If wet coring methods are used to cut through a pavement layer, that coring fluid should be removed immediately and the DM-DCP test should be performed at the same time. Coring fluid must not be allowed to soak into or penetrate the material to be tested— this will have a significant affect on the testing results.

Use a wet/dry vacuum or suitable alternative after the completion of drilling or coring to remove loose material and fluid from the access hole before testing. To minimize the extent of the disturbance from the rotary hammer, drilling should not be taken completely through the bound layer, but stopped short by about 10 to 20 mm. The DM-DCP will then be used to penetrate the bottom portion of the bound layer. This scenario requires tests to determine layer thickness.

### **Pavement With Thin Seals Testing**

This type of testing involves advancing the cone of the DM-DCP through the seal until the top of the widest part of the cone is flush with the layer to be tested. This position should serve as your starting point for the test. A reference reading should be taken for this point, which includes the thickness of the layers that may have been cored through. This reference reading is the point from which the subsequent penetration is measured.

## Data Recording and Tabulation

A form like the one shown in Figure #3 on the next page, is very helpful for recording test data. A copy of this sheet can be downloaded from the Humboldt website:

<https://www.humboldtmg.com/manuals/collectionsheet.pdf>.

Figure #2 shows this form with test data.

- The raw test data can be recorded under the # of Blows column and the Cumulative Penetration (mm) column (columns 1 and 2). If the moisture content is known, it can be entered in the column Moisture % (column 7).
- This form also has columns to record Penetration Increase for each individual reading (column 3).
- The Penetration per Blow (mm), (column 4), is column 3 divided by column 1 and serves as the DCP Index mm/blow.
- Hammer Blow Factor (column 5) is (1) for the 17.6lb (8kg) hammer and (2) for the 10.1lb (4.6kg) hammer.
- The CBR % (column 6) is provided by the DCP Index Correlation, (Figure #2).

Raw Test Data		DCP Index		Hammer Blow Factor	CBR %	Moisture %
# of Blows	Cumulative Penetration (mm)	Penetration Increase (mm)	Penetration per Blow/mm			
0	0					5
5	25	25	5.0	1	50	5
5	55	30	6.0	1	40	5
15	125	70	4.7	1	50	5
10	175	50	5.0	1	50	5
5	205	30	6.0	1	40	5
5	230	25	5.0	1	50	5
10	280	50	5.0	1	50	5
5	310	30	6.0	1	40	5
5	340	30	6.0	1	40	5
5	375	35	7.0	1	35	5
5	435	60	12.0	1	18	5
				1		
				1		

Figure #2

DM-DCP Data Form with Data

Webster, S.L., Grau, R.H. Williams, T.P., (May 1992), Description and Application of Dual mass Dynamic Cone Penetrometer, Report GL-92-3, Department of the Army, Washington D.C., Pg 19



DCP Index mm/blow	CBR %	DCP Index mm/blow	CBR %
<3	100	51	3.6
3	80	52	3.5
4	60	53-54	3.4
5	50	55	3.3
6	40	56-57	3.2
7	35	58	3.1
8	30	59-60	3.0
9	25	61-62	2.9
10-11	20	63-64	2.8
12	18	65-66	2.7
13	16	67-68	2.6
14	15	69-71	2.5
15	14	72-74	2.4
16	13	75-77	2.3
17	12	78-80	2.2
18-19	11	81-83	2.1
20-21	10	84-87	2.0
22-23	9	88-91	1.9
24-26	8	92-96	1.8
27-29	7	97-101	1.7
30-34	6	102-107	1.6
35-38	5	108-114	1.5
39	4.8	115-121	1.4
40	4.7	122-130	1.3
41	4.6	131-140	1.2
42	4.4	141-152	1.1
43	4.3	153-166	1.0
44	4.2	166-183	0.9
45	4.1	184-205	0.8
46	4.0	206-233	0.7
47	3.9	234-271	0.6
48	3.8	272-324	0.5
49-50	3.7	>324	<0.5

Figure 4:  
Tabulated Correlation of CBR versus DCP Index

## Data Correlations

An estimate of the CBR value can be determined using the DCP index (column 4 on the DM-DCP Data Form on page 11/12 of this manual) and the Tabulated Correlation of CBR versus DCP Index, Figure #4 on page 13 of this manual.

To do this, first, using your test results on the DM-DCP Data Form, compute the DCP Index or Penetration per Blow/mm (Column 4) by dividing the Penetration Increase (mm) (Column 3) by the Number of Blows (Column 1) of the DM-DCP Data Form.

The DCP Index (Penetration Increase mm) is then used to estimate in-situ CBR or shear strength using the appropriate correlation for the reference.

### Example:

The correlation of penetration per blow (DCP Index) in Figure #4 is derived from the equation  $CBR = 292 / PR^{1.12}$  as recommended by the US Army Corps of Engineers.

This equation is used for all soils except for CL soils below 10% CBR and CH soils. For these two exceptions, the following equations are recommended by the US Army Corps of Engineers:

CL soils  $CBR < 10$ :  $CBR = 1 / (0.017019 \times PR)^2$

CH soils:  $CBR = 1 / (0.002871 \times PR)$

(Selection of the appropriate correlation is a matter of professional judgment.)

Other correlations include: MR between 1300 to 1500 CBR.

If a distinct layering exists within the material tested, a change of slope on a graph of penetration/blow vs depth will be observed for each layer. The exact interface is difficult to define because, in general, a transition zone exists between layers. The layer thickness can be defined by the intersection of the lines representing the average slope of adjacent layers. Once the layer thicknesses have been defined, the average penetration rate per layer is calculated.

### Excel Template

To aid in the determining CBR values, we offer a Microsoft Excel® template on our website at: <https://www.humboldtmg.com/manuals/dcp-cbr-Spreadsheet-Template.xlsm>

This template automatically charts CBR and PSF values based on the DCP test results you enter (See instructions below).

## Excel Template Instructions

1. Open the file [dcp-cbr-Spreadsheet-Template.xlsm](#) in Microsoft Excel version 5 or later
2. Click on cell C4 and type the **Project Name**, then hit enter key.
3. Enter a **Test Location Name** in cell C5, then hit enter key.
4. Enter the data **Day-Month-Year** in cell G4, then hit enter key.
5. Choose a **Soil Type** by Clicking on the soil type CH, CL, or All other soils. If the soil type is not known, choose All other soils and describe the soil in cell G5.
6. Choose a **Hammer Type**, select either 10.1 lb, or the Both hammers used for 17.6 lb.
7. Type in test data in cells A13-55 and B13-55. Also, if cells C13-55 are blank, enter 1 when using the 17.6 lb (8kg) hammer or 2 when using the 10.1 lb (4.6kg) hammer.
8. CBR vs Depth will plot automatically.
9. Save button can be used to save the test data. When the file is saved, the name is printed on the data sheet below ADCP TEST DATA@
10. DELETE button will delete current DCP test data and prepare the spreadsheet for entering new test data. PROJECT, LOCATION, DATA, SOIL, TYPE, and HAMMER information will have to be updated.
11. PRINT will print the DCP data sheet including the CBR vs Depth graph and profile drawing.
12. You can click on the graph or profile drawing and cut and paste them into other window programs or change them to suit your needs.

## **Maintenance**

Normal usage of your DM-DCP results in wear of the metal parts that make up the device. In order to ensure maximum service life, periodic inspections of the DM-DCP for fatigue or damage should be done. Any parts found to be fatigued or damaged should be replaced. The DM-DCP should be kept clean and all soil removed from the Drive Rod and Hardened Point before each test. The drive rod should be kept clean and lubricated with oil.



# Humboldt Dual-Mass, Dynamic Cone Penetrometers

ASTM D6951

## Overview

Developed by the Army Corps of Engineers, Dual-Mass, Dynamic Cone Penetrometers (DM-DM-DCP) provide a low-cost, efficient test method for quickly determining in-situ estimated CBR values of pavement base, sub base and sub grades. DMDM-DCPs are primarily used to determine in-place soil shear strength in road construction with CBR values from less than 0.5 to 100% and bearing values ranging from 430 to 10,800 psf. They are typically used to assess materials at depths up to 30" (750mm), but can use extensions to extend that range to 6ft. (2m). All Humboldt DM-DCPs comply with ASTM D6951 specifications and come with a chart to compute CBR values.

Dual-Mass, Dynamic Cone Penetrometers (DM-DCP) are used to assess the in-place strength of undisturbed soil and/or compacted materials. The penetration rate can be used to estimate CBR (California Bearing Ratio), shear strength of strata, thickness of strata and bearing capacity. It is typically used in horizontal construction applications, such as pavements, runways and shallow foundations. Typically, the DM-DCP is used to assess material properties to a depth of 30" (750mm) below the surface. However, with the use of extensions the Drive Rod can be advanced to 6' (2m).

The DM-DCP can be used to estimate the strength characteristics of fine-grained soils, granular construction materials and weak stabilized or modified materials. The DM-DCP should not be used in highly-stabilized or cemented materials or for granular materials containing a large percentage of aggregates greater than 2" (50mm) in size.



User has the choice of using the Hard Tip Cone or the Disposable Cone Adapter with Disposable Cones.

It can also be used to estimate the strength of in-situ materials underlying a bound or highly-stabilized layer by first drilling or coring an access hole.

A field DM-DCP measurement results in a field or in-situ CBR and will not normally correlate with the laboratory or soaked CBR of the same material. The test is thus intended to evaluate the in-situ strength of a material under existing field conditions.

**NOTE:** The DM-DCP may be used to assess the density of a fairly uniform material by relating to penetration rate on the same material. In this way under-compacted soil or "soft spots" can be identified, even though the DM-DCP does not measure density directly.

Humboldt's DM-DCPs are known for their high-quality manufacturing and reliability, and, are available with either threaded connections or with a quick-connect design. Both Humboldt DM-DCPs feature our exclusive easy-grip hammer that provides a finger grip machined into the back side of the hammer flange, which provides easy, non-slip lifting when performing a test.

Humboldt DM-DCPs feature a dual-mass 8kg (17.64 lb) drive hammer assembly, which consists of the dual-mass weight, a hammer rod with a handle on one end and either a threaded or quick-connect connection on the other. They also include a drive rod with either a 60° hardened, cone tip or disposable cone adapter and cone.

The cone tip is driven into the soil by means of dropping the sliding dual-mass hammer a prescribed distance, forcing the cone tip into the ground. The diameter at the base of the cone is 20mm, which is 8mm larger than that of the extension shaft. This ensures that the resistance to penetration is exerted on the cone and not affected by the extension shaft.

Humboldt DM-DCPs can quickly convert to a single-mass 4.6kg (10.1 lb) DCP by removing the hexagonal set screw in the hammer and removing the outer steel sleeve. The 4.6kg hammer is more suitable for use and yields better test results in weaker soils having CBR of 10% or less. It can be used for evaluating soils in foundations for residential structures, which require a bearing value of 2000 PSF (approximately a CBR of 6%). The 8kg (17.64 lb) hammer is used to penetrate high strength soils quicker and may be preferred when these types of soil are encountered. However, the hammer can be used on soils up to a CBR of 80%.

# Humboldt, Dual-Mass Dynamic Cone Penetrometers



## H-4219QC — Quick-Connect Version



Quick-Connect Ends



Includes a hard-cone tip and a disposable cone Adapter



Pelican case

### Dual-Mass, Dynamic Cone Penetrometer with Threaded Connectors

ASTM D6951

DCP w/ Quick-Connect Connectors **H-4219QC**  
Ship wt. 65lbs. (29.5kg)

Included with the H-4219QC DCP:

Description	Model
Dual-Mass DCP Hammer, Quick-Connect Connection	H-4219QC.1
Drive Rod, Quick-Connect, 37.75" (959mm)	H-4219QC.2
Quick-Connect Pins (2)	H-4219QC.18
Disposable Cone Adapter	H-4219.5
Hard Cone Tip	H-4219.4
Disposable Cones (pkg of 25)	H-4219.25
Scale, 48"	H-4219.2
Single-User Scale Guide Set	H-4219.17
Wrench Set (Quick-Connect)	H-4219QC.7
User Manual	H-4219.MAN
Go, No-Go Gauge	H-4219.3
Pelican Case	H-4219.16

# Humboldt, Dual-Mass Dynamic Cone Penetrometers



## H-4219T — Threaded Version



Threaded Ends



Includes a hard-cone tip and a disposable cone Adapter



Pelican case

### Dual-Mass, Dynamic Cone Penetrometer with Threaded Connectors

ASTM D6951

DCP w/ Threaded Connectors

H-4219T

Ship wt. 65lbs. (29.5kg)

Included with the H-4219T DCP:

Description	Model
Dual-Mass DCP Hammer, Threaded Connection	H-4219T.1
Drive Rod, Threaded, 37.75" (959mm)	H-4219T.2
Disposable Cone Adapter	H-4219.5
Hard Cone Tip	H-4219.4
Disposable Cones (pkg of 25)	H-4219.25
Scale, 48"	H-4219.2
Single-User Scale Guide Set	H-4219.17
Wrench Set (Threaded)	H-4219T.7
User Manual	H-4219.MAN
Go, No-Go Gauge	H-4219.3
Pelican Case	H-4219.16

# Dual-Mass DCP Accessories



H-4219QC.12



H-4219T.12



H-4219.8



H-4219.100

Accessories	Model
Drive Rod, 12-inch Threaded	H-4219T.12
Drive Rod, 12-inch Quick-Connect	H-4219QC.12
Extension Rod, 24-inch, Threaded (For use with both Quick-Connect and Threaded models)	H-4219.8
Disposable Cones (100 pk.)	H-4219.100





### **Warranty**

Humboldt Mfg. Co. warrants its products to be free from defects in material or workmanship. The exclusive remedy for this warranty is Humboldt Mfg. Co., factory replacement of any part or parts of such product, for the warranty of this product please refer to Humboldt Mfg. Co. catalog on Terms and Conditions of Sale. The purchaser is responsible for the transportation charges. Humboldt Mfg. Co. shall not be responsible under this warranty if the goods have been improperly maintained, installed, operated or the goods have been altered or modified so as to adversely affect the operation, use performance or durability or so as to change their intended use. The Humboldt Mfg. Co. liability under the warranty contained in this clause is limited to the repair or replacement of defective goods and making good, defective workmanship.

Humboldt Mfg. Co.  
875 Tollgate Road  
Elgin, Illinois 60123 U.S.A.

U.S.A. Toll Free: 1.800.544.7220  
Voice: 1.708.456.6300  
Fax: 1.708.456.0137  
Email: [hmc@humboldtmfg.com](mailto:hmc@humboldtmfg.com)

Testing Equipment for



Construction Materials

# **HUMBOLDT**

[www.humboldtmfg.com](http://www.humboldtmfg.com)