

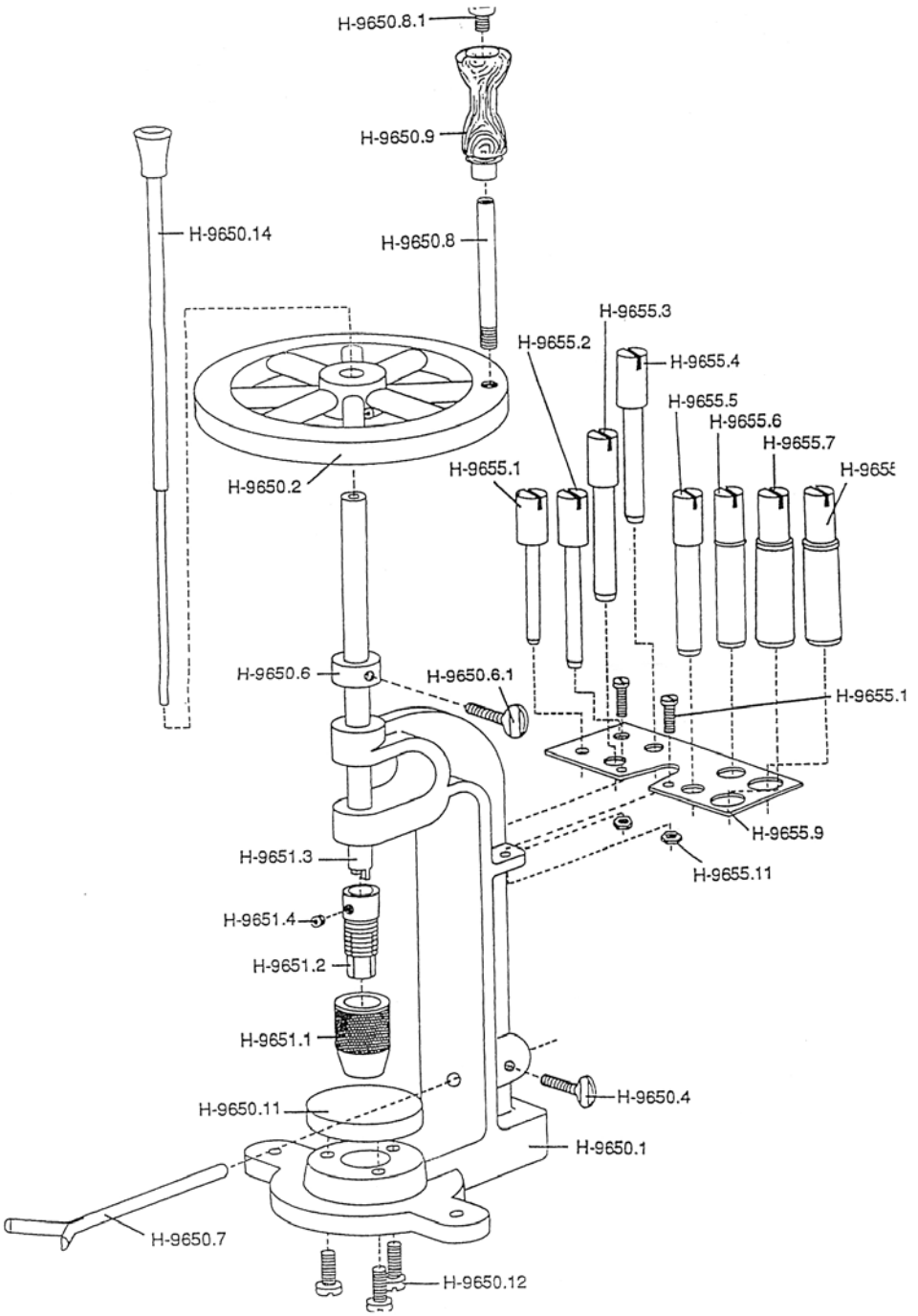

Cork Borer

Instructions

1. Insert proper size cork borer into chuck.
NOTE: Remember the hole will be the ID of the tube!
2. After making sure the borer is in the cog inside the chuck, tighten chuck so borer is held securely.
3. Place object to be bored on white nylon disk and lower borer to top surface.
4. Hold object to be bored with one hand while turning handle with other hand and slowly bore hole.
5. After hole is bored, eject the blank from inside the tube and push rod. Remove borer from chuck and return it to the rack.



Warranty

Humboldt Mfg. Co. warrants its products to be free from defects in material or workmanship. The exclusive remedy for this warranty is Humboldt Mfg. Co., factory replacement of any part or parts of such product, for the warranty of this product please refer to Humboldt Mfg. Co. catalog on Terms and Conditions of Sale. The purchaser is responsible for the transportation charges. Humboldt Mfg. Co. shall not be responsible under this warranty if the goods have been improperly maintained, installed, operated or the goods have been altered or modified so as to adversely affect the operation, use performance or durability or so as to change their intended use. The Humboldt Mfg. Co. liability under the warranty contained in this clause is limited to the repair or replacement of defective goods and making good, defective workmanship.

Humboldt Mfg. Co.

875 Tollgate Road
Elgin, Illinois 60123 U.S.A.

U.S.A. Toll Free: 1.800.544.7220

Voice: 1.708.456.6300

Fax: 1.708.456.0137

Email: hmc@humboldtmgf.com

Testing Equipment for



Construction Materials

HUMBOLDT

www.humboldtmgf.com