

Testing Equipment for



Construction Materials

# HUMBOLDT

## Boekel Cement Autoclave

### H-3240

## Operating Instructions

(Please read before operating equipment)

#### CHECK LIST CEMENT AUTOCLAVE

The contents of this shipment should be checked against the list below. If any item is missing, notify the Boekel Customer Service Department at 215-396-8200

- 1 Manufacturer's Data Report (P-2)
- 1 Operating Instructions (N2400021)
- 1 Boekel Cement Autoclave
- 1 Thermometer (NP22507)
- 1 Package of 5 Gaskets
- 1 T-Handle Socket Wrench (NP36328)
- 1 Short Arm Wrench (NP35147)

N2400021 Rev 1 04/06

## CONTENTS

	Page
1. INTRODUCTION.....	4
2. DESCRIPTION (Ref: Figure 1).....	4
2.1 General.....	4
2.2 Regulator (Ref: Figure 2).....	4
2.2.1 Range.....	4
2.2.2 Differential.....	5
2.3 Safety Valve.....	5
2.4 Cylinder and Cylinder Head.....	5
2.5 Vent Valve.....	5
2.6 Gaskets.....	5
3. SPECIFICATIONS.....	5
4. OPERATION.....	6
4.1 Trial Runs.....	6
4.2 Preliminary Adjustments.....	6
4.3 Heating Period.....	7
4.4 Three-hour Constant Temperature & Pressure Period:.....	9
4.5 Cooling Period.....	9
4.6 Final Cooling of Specimens:.....	9
5. MAINTENANCE.....	10
5.1 Safety Valve:.....	10
5.2 Pilot Light:.....	10
5.3 Heater Replacement:.....	10
6. REPLACEMENT PARTS & ACCESSORIES.....	11

## 1. INTRODUCTION

The Boekel cement autoclave is a device for conducting accelerated soundness tests on cement according to ASTM C151. The autoclave is also suitable for other applications requiring a constant steam pressure with corresponding constant temperature within the 60-PSIG to 350-PSIG range.

## 2. DESCRIPTION (Ref: Figure 1)

### 2.1 General

The autoclave consists of a welded steel cylinder with bolted cover, mounted on a sturdy supporting frame and enclosed in a heat insulated metal housing.

The steel cylinder is fitted with a high temperature gasket and a heavy cover held in place by 16 cap screws bearing upon washers. A T-Handle wrench supplied with the autoclave may be used to tighten the nuts gradually and uniformly to make a leakproof assembly. The cylinder assembly is designed for a safe working pressure of 525 PSIG, or one and one-half the maximum working pressure. A safety valve set to release at 350 PSIG is provided for protection. A dial pressure gage indicates the steam pressure in PSIG. Temperature readings are taken with a No. NP22507 thermometer ASTM #2F, which is placed in the thermometer well provided in the cylinder cover. An air-vent valve allows the escape of entrapped air during the early part of the heating period and releases any steam pressure remaining at the end of the cooling period.

The autoclave is heated by two electric heaters attached to the cylinder. The heating unit is controlled from a switch panel on the control box. The control box houses the pressure regulator.

A main toggle switch controls the entire electrical circuit including the automatic regulator. Separate on-off toggle switches, in series with pilot lights, control the current to the two heating elements. Switch functions are indicated on the switch panel.

### 2.2 Regulator (Ref: Figure 2)

The pressure regulator controls pressures between 60 and 350 PSIG. It is located inside the control cabinet and is provided with two screws. One screw is for adjustment of the "range" and the other screw is for adjustment of the "differential".

#### 2.2.1 Range

The "Range" adjustment screw, when turned clockwise, raises the "make" and "break" points of the circuit. The differential between "make" and "break" points, however, is not altered by the screw adjustment. This screw has been factory set to maintain cylinder pressure of  $295 \pm 10$  PSIG.

### 2.2.2 Differential

The "differential" adjustment screw should be turned clockwise as far as possible to reduce the differential between "make" and "break" to a minimum for close control during the constant pressure period. This screw has been factory set to the minimum position.

### 2.3 Safety Valve

The safety valve is mounted on the bolted cover of the autoclave. It has tested and set to release at 350 PSIG. It complies with Section I of the A.S.M.E. Boiler and Pressure Vessel Code. The manufacturer guarantees that this valve has a capacity to release at least 1000 lbs. of steam per hour. Since the autoclave contains only enough water to generate about 1.3 lbs. of steam, this valve has many times the capacity required in autoclave operations.

### 2.4 Cylinder and Cylinder Head

The welded steel cylinder and the cylinder head have been designed and tested to withstand a pressure of 525 PSIG. This translates into a maximum allowable working pressure of 350 PSIG.

### 2.5 Vent Valve

The vent valve is a needle valve located in the piping system which links up to the cylinder, pressure gage and the regulator.

### 2.6 Gaskets

The high temperature gaskets furnished with the autoclave have been found to give more service, satisfactorily and at a lower cost, than the many types of special gaskets available on the market.

## 3. SPECIFICATIONS

For cement soundness tests, the autoclave will accommodate either a Specimen Holder for 8 test bars of 10-inch effective gage length or a Specimen Holder for 16 test bars of 5-inch effective gage length. The automatic pressure regulator is set for this purpose to maintain a steam pressure of  $295 \pm 10$  PSIG which corresponds to a temperature of  $420^\circ \pm 3^\circ$  F. A maximum of 75 minutes is required to heat the autoclave to this temperature. When the current to the heaters is cut off and the cover is removed, cooling to a steam pressure of 10 PSIG within one and one half hour interval is accomplished by adjustment of the draft control lever.

Boekel Model Number	25515016
Operating Pressure Range, PSIG	60-350
Operating Voltage, Volts	115
Current Type	AC

Frequency, Cycles	50/60
Maximum Current Demand, Amperes	15.7
Maximum Power Consumption, Watts	1800

## 4. OPERATION

### 4.1 Trial Runs

It is suggested that three or more trial runs be made before using the autoclave to learn how to operate it and to determine its characteristics. In these trial runs the autoclave should be loaded with dummy specimens but should be operated step by step. Time records of temperature, pressure and data on other significant factors should be kept to provide a basis for establishing a uniform procedure. During the runs, an accurate check can be made on the pressure gage reading which corresponds to 420° F, (should be 295 PSIG).

Each autoclave has been carefully tested before shipment. During testing, the regulator was set to maintain an average pressure to 295 PSIG as indicated by the pressure gage. It is possible, however, that the setting of the regulator may be altered in transit. The need for readjustment will become apparent in the first trial run when the autoclave assembly reaches equilibrium and the regulator makes and breaks the heating circuit three or four times. The range adjustment screw should be gradually adjusted so that the regulator opens the circuit (pilot light cuts off) when the pressure gage attains 295 PSIG. Usually the regulator will close the circuit at 5 PSIG below 295, provided the differential adjustment screw is turned clockwise as far as possible. The position of this screw should be checked occasionally. The thermometer should also be checked to see that it indicates temperature correctly at 420° F with the pressure gage reading of 295 PSIG.

### 4.2 Preliminary Adjustments

- 1) Clean and dry thoroughly the interior of the cylinder before adding any water. Put 600cc of distilled water in the cylinder.
- 2) Clean the gasket groove located inside the bolt circle of the cylinder flange. It is very important that this groove not be scratched or otherwise marred during cleaning.

Coat both sides of a fresh gasket with a high temperature lubricant, such as dry graphite, applied either by aerosol or brush.

The coating will reduce the adherence of the gasket.

Carefully place the gasket in the groove. Use a fresh gasket for each run.

- 3) Place the specimen holder with specimens in the cylinder. The specimen holder rests on the ledge near the bottom of the cylinder.
- 4) Inspect the seal ring of the cylinder head and remove all gasket material adhering to it. Place the cylinder head loosely on the gasket with the bolt holes matching. The cylinder head should be set in such a way that the thermometer well and safety valve are in the position most convenient for the operator.

**IMPORTANT: OUTLET PORT OF SAFETY VALVE SHOULD BE POSITIONED AWAY FROM THE OPERATOR.**

The clearance between the top spider of the short-bar specimen holder and the bottom the cylinder head is usually less than the corresponding clearance for the holder designed for the eight longer bars. Therefore, the short-bar specimen holder must be placed in the cylinder so that the thermometer well in the bottom of the cylinder head will protrude into one of the holes provided in the top spider of the holder.

- 5) Insert the sixteen alloy steel 7/16 inch hex head bolts (cap screws) after applying graphite to their threads. The T-handle socket wrench provided with the autoclave should be used to tighten the bolts gradually, uniformly and systematically, according to the diagram in Figure 3 and the following directions:

First tighten the bolts in opposite pairs in the sequence, 1, 2, 3, 4, etc., indicated in Figure 3, so that each bolt exerts only a slight pressure on the cylinder head. Repeat the gradual tightening of the bolts at least two more times, following the same numerical order. Tighten the bolts progressively around the bolt circle. Repeat this tightening sequence two or three times until all the bolts are bearing firmly and uniformly against the cylinder head.

- 6) Move the draft lever to the "closed" position, at the extreme right. This reduces the draft through the autoclave to the small amount desired for uniform temperature control. The damper should be left closed until the beginning of the cooling period, as described on the following pages.
- 7) Place the large insulated cover on top of the autoclave.
- 8) Check to see if the vent valve is open to vent the air freely during the early part of the heating period.
- 9) Place the thermometer in the well provided in the cylinder head.

#### 4.3 Heating Period

- 1) Note the time and read the temperature indicated by the thermometer.

- 2) Turn on the heating current by snapping all three switches to the ON position (right). The heater has two separate sections, each controlled by a snap switch. A pilot lamp adjacent to each switch indicates which section of the heater is operating.
- 3) There will be very little evidence of a temperature rise during the first five minutes. Thereafter, the thermometer at the top of the autoclave will show a rapid temperature rise, indicating approximately 200° F after approximately 20 minutes. During this period air will be forced out of the cylinder through the open vent valve. After the air has been expelled, steam will begin to appear and finally to escape as a fine jet. When this occurs, perform the following operations:
  - a) Close the vent valve firmly by hand. (Do not use wrench or pliers for closing). If foreign matter gets on the valve seat it may cause the valve to leak. The matter can usually be blown out by opening and closing the valve several times. The packaging nut on the valve stem should be moderately tight to prevent excessive stem wear.
  - b) Remove the thermometer and insulated cover. Tighten the bolts gradually and evenly for the second time, proceeding around the bolt circle three or more times to achieve uniform clamping pressure of each bolt against the cylinder head and gasket.
  - c) Replace the cover and the thermometer, and continue to check the temperature and pressure at five minutes or shorter intervals, as desired.
- 4) Soon after the vent valve is closed, the gage will indicate the development of steam pressure, first slowly, then more and more rapidly until it indicates a pressure of about 160 PSIG. During this period the temperature of the steam, indicated by the thermometer will also rise, reaching approximately 370° F (at a pressure of 160 PSIG). When this condition is attained, perform the following operations:
  - a) Turn off heater #2 by snapping its switch to the OFF position. LEAVE THE MAIN SWITCH ON.

This lowers the heating rate and brings the autoclave temperature to the desired pressure of 295 PSIG without an overshoot of more than 10 PSIG. Without this reduction in heat input at the proper time, it is possible to overshoot 10° to 15° F in temperature and 30-50 PSIG in steam pressure, even though the regulator cuts off all current at 295 PSIG. The overshoot would be unavoidable due to the heat capacity of the apparatus. With switch #2 in the OFF position, only one of the two heating coils is in use, yet enough power is supplied to raise the pressure of the apparatus from 160 to 295 PSIG within the allowable heating period.

- b) Remove the thermometer and insulated cover. Then gradually tighten the bolts for the third time as carefully as before. This final adjustment is necessary for the successful operation of the autoclave, as it tends to prevent leakage of steam

through the gasket and thereby conserves the small quantity of water at the bottom of the cylinder.

- c) Replace the cover and the thermometer.

#### 4.4 Three-hour Constant Temperature & Pressure Period:

During this period, Switch #1 and the Main Switch remain ON and the temperature is automatically maintained by the sensitive controller which switches the current on and off (indicated by the pilot light) through the relay. When the system is tight enough so that no steam or water is lost by leakage (and the draft lever remains in the "closed" position) the heating current will be on for about 40-50% of the time.

#### 4.5 Cooling Period

At the end of the three-hour constant temperature and pressure period, proceed as follows:

- a) Turn the main switch to the OFF position.
- b) Remove the thermometer. Remove the insulated cover and replace the thermometer.
- c) Move the draft lever to the OPEN position on the extreme left.

This increases the amount of cold air, which enters the cylindrical opening at the bottom of the autoclave and leaves through the annular space at the top of the autoclave. The circulation of cold air around the walls of cylinder by natural draft greatly facilitates rapid and uniform cooling.

Under these conditions the gage pressure will decrease to about 10 PSIG within one and one-half hours. At the end of this period, proceed as follows:

- d) Open the vent valve to equalize the pressure in the cylinder with atmospheric pressure.
- e) After the excess pressure has been released, remove the bolts and cylinder head.
- f) Remove the gasket from the groove in the cylinder and remove any pieces adhering to the cylinder head. The gasket is easily removed when it is damp and warm.

#### 4.6 Final Cooling of Specimens:

After opening the cylinder, place the test specimens in water at a temperature above 194° F (90° C). Cool the water surrounding the specimens at a uniform rate by adding cold water so that the temperature of the water will be lowered to 74° F (23° C) in 15

minutes. Maintain the water surrounding the specimens at 74° F for an additional 15 minutes, then surface dry the specimens.

As soon as the bars are removed from the cylinder, the water remaining at the bottom should be removed and the interior of the cylinder wiped clean and dry to reduce incrustation and corrosion.

## 5. MAINTENANCE

### 5.1 Safety Valve:

It is strongly recommended that a spare Safety Valve be purchased (Boekel Model No. NP16016). Once a year the valve should be removed and replaced with the spare valve. The used valve should be sent to the valve manufacturer for cleaning, adjusting, and setting. Upon its return, the valve may be kept as a spare.

The valve seat has been specially ground to be pressure-tight at the normal working pressure of 295 PSIG, which is 55 PSIG below the 350 PSIG release setting. It is possible however, that a valve will leak slightly, particularly if it has been lifted from its seat. If leaks develop, lift the valve from its seat (by means of hand operated lifting lever) and brush the valve and seat bearing surfaces with a moderately thick soap solution. In reseating the valve, the lifting lever should be lowered gradually and should never be allowed to snap back into position. **DO NOT MAKE THIS ADJUSTMENT WHEN STEAM PRESSURE IS UP.**

NOTE: The safety valve on the autoclave may or may not have this lever depending on the style available at the time of manufacture.

### 5.2 Pilot Light:

Pilot lights may become loose in transit; they can be tightened after unscrewing the chrome-plated cover and replaced with a Boekel No. NP 20250 Neon Glow Lamps.

### 5.3 Heater Replacement:

Should it become necessary to replace the autoclave heating unit, contact the Boekel Customer Service Department to obtain authorization to return the autoclave. The heater can only be replaced at the factory.

## 6.

## REPLACEMENT PARTS & ACCESSORIES

<u>Description</u>	<u>Boekel Model No.</u>
Cement Autoclave, Menzel	25515-016
Replacement Safety Valve	NP16016
Autoclave Gaskets, 50/Pkg.	25517-001
Vent Valve	NP16015
Neon Lamp	NP20250
Relay, 115 volt, 50/60 HZ	NP20707
Pressure Regulator	NP38131
Cap Screws, (set of 16)	NP29675
Pressure Gage, 0 to 600 P.S.I.	NP35287
Thermometer, 20 to 580° F, ASTM 2 F	NP22507
Toggle Switch	NP20982

FIGURE # 1  
AUTOCLAVE ASSEMBLY

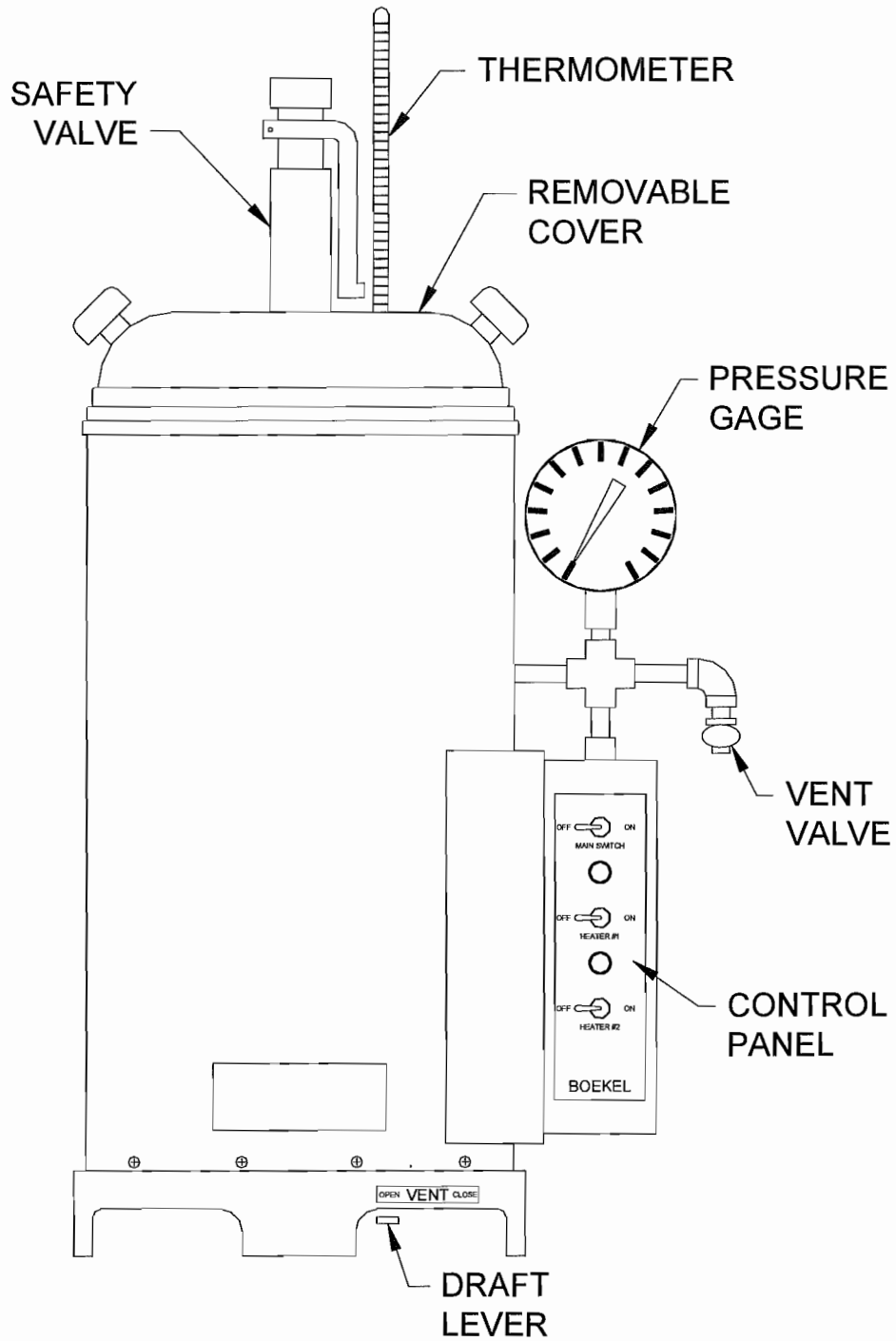
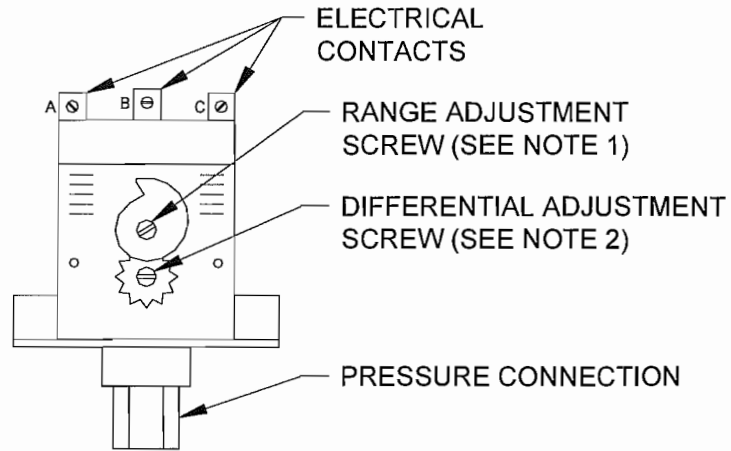

FIGURE # 2  
PRESSURE REGULATOR



NOTE 1: FACTORY SET AT OPERATING  
PRESSURE OF  $295 \pm 10$  P.S.I.

NOTE 2: FACTORY SET AT MINIMUM

FIGURE # 3  
BOLTING DIAGRAM

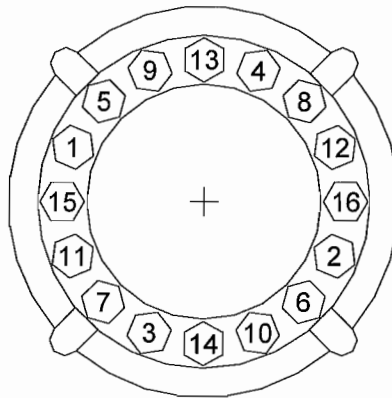

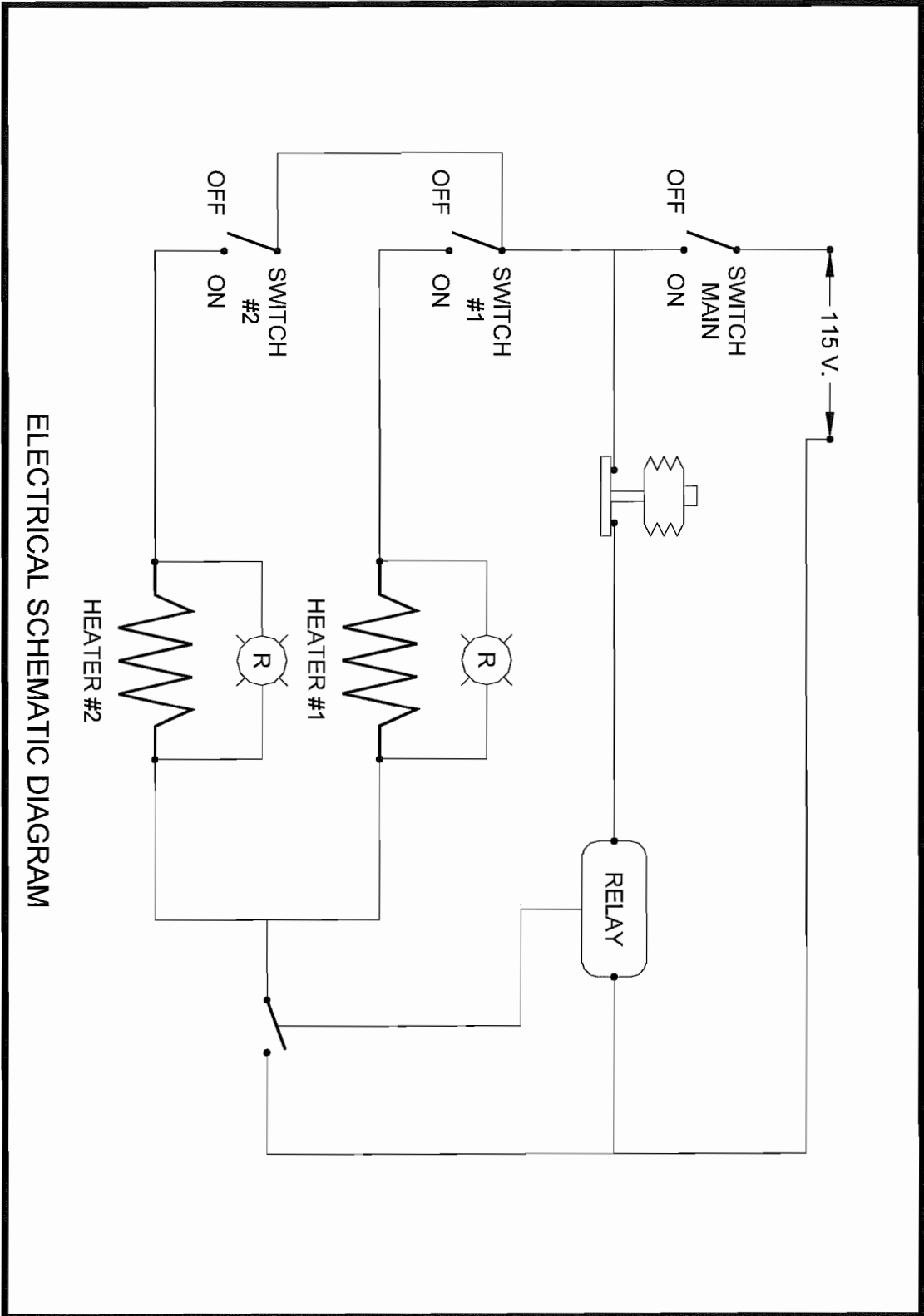

ELECTRICAL SCHEMATIC DIAGRAM