

Ductility Machine



## General

The ductility test is a measure of the distance to which a bituminous material will elongate before breaking when two ends of a standard specimen are pulled apart at a uniform rate.

The suggested method of test is covered by ASTM D113 and AASHTO T51. In the absence of any specified variations in the test method, the test procedure as outlined in these instructions may be followed.

## Installation

These units are shipped complete, ready for operation. Standard units are supplied for operation on 110 volt, 60 cycles, A.C. operation. Be sure the line cord is plugged into the proper-grounded electrical outlet. The unit should be leveled and mounted on a flat surface. For best results the unit should be mounted on four rubber pads.

## Sample Preparation

1. Unless otherwise specified the test should be conducted at a temperature of  $25 \pm 0.5^{\circ}\text{C}$  ( $77 \pm 0.9^{\circ}\text{F}$ ) and with a speed of 5 cm per minute  $\pm$  5.0 percent. When a low-temperature ductility test is desired, the test should be made at a temperature of  $4^{\circ}\text{C}$  ( $39.2^{\circ}\text{F}$ ) and at a rate of pull or 1 cm per minute.
2. Assemble the mold on the brass plate. To prevent the material under test from sticking, it is suggested that the surface of the plate and interior surfaces of the sides of the mold be thoroughly amalgamated. Make sure the plate is perfectly flat and level so that bottom surface of the mold will touch it throughout.
3. Completely melt the bituminous material to be tested until thoroughly fluid by heating it in an oil bath maintained at the minimum temperature needed to properly liquefy the sample, when paving asphalt cements are to be tested, the oil bath should be maintained at a temperature of 150 to  $160^{\circ}\text{C}$  (302 to  $320^{\circ}\text{F}$ ).
4. Strain the melted sample through a No. 50 sieve. After stirring thoroughly, pour into the mold, taking care not to disarrange the parts of the mold. Pour the material back and forth in a thin stream from end to end of the mold until the mold is more than level full.
5. Allow the mold containing the material to cool to room temperature for a period of 30 to 40 minutes. Then place the mold in the water bath maintained at the specified temperature of test for 30 minutes. Cut off the excess bitumen with a hot straight edged knife or spatula to make the mold level full.
6. Place the brass plate and mold, with the briquette specimen, in the water bath and keep them at the specified temperature for a period of from 85 to 95 minutes. After the elapsed period of time, remove the briquette from the plate, detach the side pieces, and immediately test the briquette.

## Test Procedure

1. Fill the trough with water until the level reaches a point where it will cover the test specimen by at least 2.5 cm both above and below.
2. Bring the water to the desired test temperature. During the test, the water should be kept at the specified temperature within  $\pm 0.5^{\circ}\text{C}$  ( $0.9^{\circ}\text{F}$ ).
3. To adjust the speed of carriage move knurled knob at the end of the sliding gear all the way in for  $\frac{1}{4}$  cm per minute, half way out for 1 cm per minute and all the way out for 5 cm per minute. Be sure to locate positioning lever in the proper slot-this will not only locate, but will also lock the gears in their exact alignment.
4. Place the specimen in position by setting one end of the specimen mold onto one of the three mounting pins on the end plate. Set the other end of the mold onto the corresponding pin on the movable carriage.
5. Move the length indicator to the zero position by loosening the adjusting screw.
6. Measure the distance in centimeters through which the clips have been pulled to produce rupture.
7. At the completion of the test, return the carriage to the starting position.

*Note: If the test material comes in contact with the surface of the water or the bottom of the bath, the test is not considered satisfactory. The specific gravity of the bath may be adjusted by the addition of either methyl alcohol or sodium chloride to prevent the bituminous from coming to the surface of the water or touching the bottom of the bath during the test.*

## Test Report

The test is considered normal when the rupture occurs at the point where the thread has practically no cross-sectional area.

The average of three normal tests is reported as the ductility of the sample.

## Maintenance

- All bearing surfaces should be kept clean.
- Threaded lead screw should be kept clean and properly greased to insure proper carriage level travel.
- When not in use, remove line cord from the outlet to prevent misuse or improper handling.

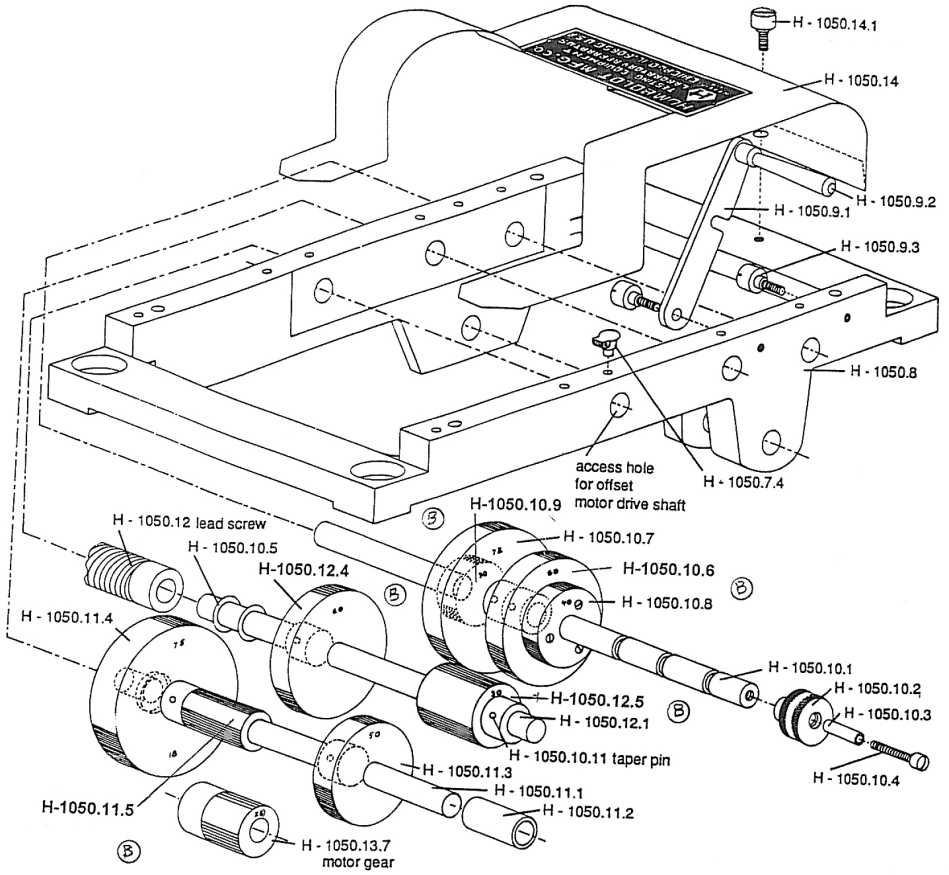

Gear Housing Frame, H-1050.8

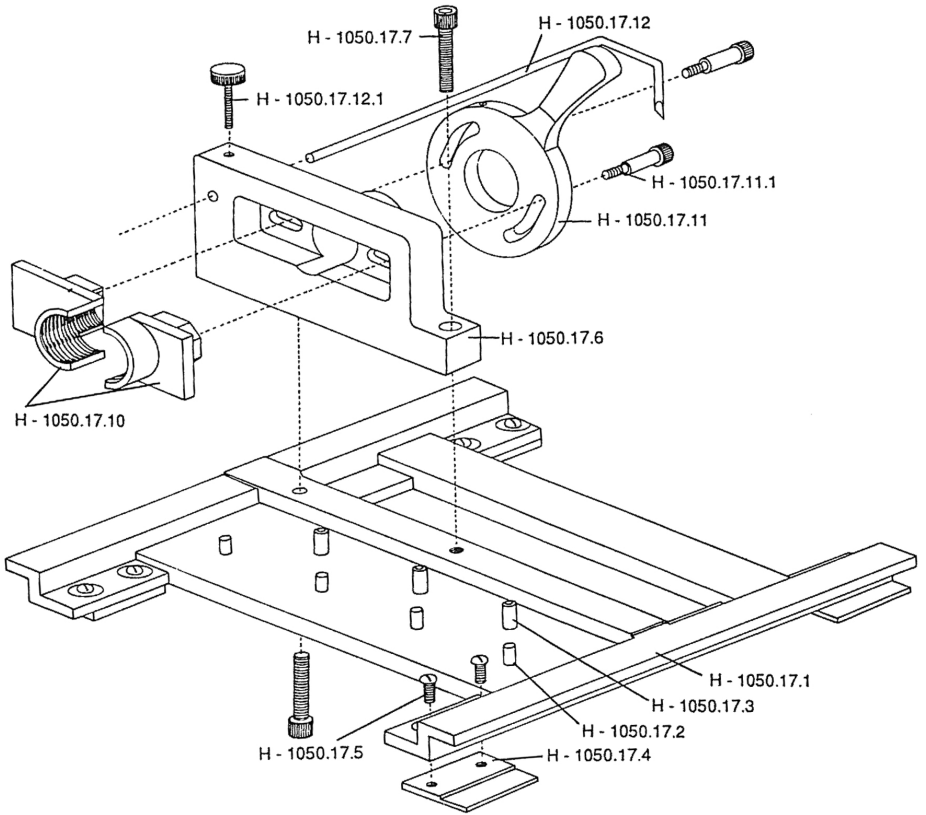

Carriage Assembly, H-1050.17



## Warranty

Humboldt Mfg. Co. warrants its products to be free from defects in material or workmanship. The exclusive remedy for this warranty is Humboldt Mfg. Co., factory replacement of any part or parts of such product, for the warranty of this product please refer to Humboldt Mfg. Co. catalog on Terms and Conditions of Sale. The purchaser is responsible for the transportation charges. Humboldt Mfg. Co. shall not be responsible under this warranty if the goods have been improperly maintained, installed, operated or the goods have been altered or modified so as to adversely affect the operation, use performance or durability or so as to change their intended use. The Humboldt Mfg. Co. liability under the warranty contained in this clause is limited to the repair or replacement of defective goods and making good, defective workmanship.

### **Humboldt Mfg. Co.**

875 Tollgate Road  
Elgin, Illinois 60123 U.S.A.

U.S.A. Toll Free: 1.800.544.7220

Voice: 1.708.468.6300

Fax: 1.708.456.0137

Email: [hmc@humboldtmfg.com](mailto:hmc@humboldtmfg.com)

Testing Equipment for



Construction Materials

# HUMBOLDT

[www.humboldtmfg.com](http://www.humboldtmfg.com)