



# H-1200, H-1250, H-1252



## Cone Penetrometers

# Introduction

## Universal Penetrometer — H-1200

Direct-reading instrument for precision penetration measurements of bituminous materials, cement, petrolatum and waxes, as well as food, cosmetics and pharmaceutical products. Unit has 5" diameter indicator dial, graduated in 400 divisions of 0.1mm, corresponding to 40mm penetration. Zero preset to eliminate errors. Includes 47.5g plunger with 3.2mm hole, and two loading weights (50g and 100g). Overall dim. 10-1/2" x 13" x 22" (266.7 x 330.2 x 558.8mm). Meets ASTM D5, D217, D1168, D1191, D1321, D1403, D1831, D1855; AASHTO T49, T187 and others.

## Special Application Penetrometers

Description	Model	Shpg.
Grease Penetrometer: Model H-1200 penetrometer with H-2520 grease cone	H-2510	30lbs. (13.6kg)
Battery Paste Penetrometer: Model H-1200 penetrometer with H-1255 battery paste cone	H-1202	30lbs. (13.6kg)

Special Application Penetrometers are available in electric versions, like the model H-1240. Call 1-800-544-7220 for information.

## Portable Penetrometer — H-1250

Lighter and smaller than H-1200 for field work, unit's micrometer adjusts for accurate settings as well as coarse adjustment for approximate settings. Only one additional 50g loading weight is included. Overall dim. 7" x 7" x 16" (178 x 178 x 406mm). Shipping wt. 8 lbs. (3.6kg)

## Special Application Penetrometer

Description	Model	Shpg.
Portable Grease Penetrometer: Model H-1250 penetrometer with H-2520 grease cone	H-1252	8lbs. (3.6kg)

# Installation

Level the instrument carefully by means of the leveling screws on the base, sighting the spirit level from above to obtain accurate alignment. After the instrument has been leveled, avoid shifting its location. Otherwise it will be necessary to repeat the leveling process.

Insert penetrating needle or cone into the chuck and tighten the chuck screw.

Set the zero reference. Grasp the gear rack knob and pull up to release the clutch trigger. With the trigger released, raise the test plunger as high as possible. If the dial reading is not exactly zero, adjust the reading to zero by means of the zero setting screw (which is on the bottom of the dial housing) which is adjustable as required. Use a #8 Allen Wrench.

## Procedure

Add the required weights to plunger head. In adding weights and in order to make up the required load for the test, note that the weight of the test plunger itself is 47.5 grams. For example, when the specified load for grease penetrations involving the use of a grease cone is 150 grams, no weights need be added to the plunger head since the combined weight of the cone (102.5 grams) and test plunger (47.5 grams) makes up required load as specified by ASTM. Place a prepared sample in position on base.

Adjust the height of the mechanism head via the control sleeve on the main post so as to bring the point of the penetrating instrument exactly into contact with the surface of the sample. To adjust the height of the mechanism head, release the lock screw. This adjustment may be accomplished more easily by placing a weak light to one side of the sample container and observing the shadow formed by the penetrating instrument on the surface of sample, until light disappears from the point. **BE SURE TO RELOCK THE HEAD SECURELY BY MEANS OF THE LOCK SCREW AFTER THE HEIGHT ADJUSTMENT IS COMPLETED.**

Release the test plunger, allowing the penetrating instrument to descend into the sample. To release the test plunger, depress and hold the clutch trigger in its released position during the specified time required for the test. Use a stopwatch to verify release duration.

**CAUTION:** *In operating the clutch trigger, grasp the finger grip firmly with the forefinger, and with the thumb depress the clutch trigger quickly as far in as it will go. HOLD THE CLUTCH TRIGGER IN DURING THE SPECIFIED LENGTH OF THE TEST. At the specified duration, let go of the clutch trigger quickly, allowing it to lock the test plunger instantly.*

## Reading Penetration

To read the depth of penetration, push down the gear rack knob gently as far as it will go. The dial reading now indicates the depth of penetration directly in tenths of millimeters. For example: If the pointer comes to a rest at the fourth mark past the 270 point, the depth of penetration is 274 tenths of a millimeter or 27.4 millimeters.

With the Universal Penetrometer, penetration measurements can be made to a total depth of 40 mm on a single reading. On depths greater than 40 mm the dial pointer makes a complete revolution and moves past the zero position for a fraction of another revolution. Simply add the fractional revolution to determine the total depth of penetration.

Return the dial pointer to zero, as directed in the Installation paragraph. If the original zero setting has been accurate, the dial pointer will return exactly to zero and subsequent readings will check against standard gauge blocks.

We also supply a 15-gram test plunger – readily installed or removed

**CAUTION:** *Keep hands, clothing and other objects away from moving parts when the machine is in operation.*

## Penetration Needles and Cones

Application	Specification	Model	Description
Bituminous materials	ASTM D5; AASHTO T49, IP49; ASA Std., A37.1; Fed Spec. SS.R. 406C, Meth. 214.01	H-1280	Standard hardened stainless steel needle, 40-45mm exposed needle length. Wt. 2.5g.
		H-1300	Same as H-1280. Certified to ASTM accuracy by independent laboratory. Wt. 2.5g.
		H-1302	Same as H-1290. Certified to ASTM accuracy by independent laboratory. Wt. 2.5g.
		H-1290	Long hardened stainless steel needle, 50-55mm exposed needle length. Wt. 2.5g.
Waxes with 250 or less penetration	ASTM D1321	H-1310	Hardened stainless steel wax penetration needles with tapered point, blunt tip of truncated cone. Ferrule is approx. 3.2mm dia. Wt. 2.5g.
		H-1317	Same as H-1310. Certified to ASTM accuracy by independent laboratory.
Battery paste	N/A	H-1255	Hardened stainless steel tip with special plunger. Total wt. 60g ± .050g.
Joint sealant for asphalt & concrete pavements	ASTM D5329	H-1320	Resilience ball penetration tool. Total wt. 27.5g.
Grease-testing penetrometers	ASTM D217, D937 ASA Std. Z11.3	H-2520	Hollow 90° brass cone, highly polished stainless steel tip. Removable nut and stem. Wt. 102.5g.
		H-2522	Same as H-2520, completely made of stainless steel. Wt. 102.5g.
For all 90° cones		H-2525	Stainless steel replacement tip, nut and stem.
Grease-testing penetrometers	ASTM D2884	H-2524	Magnesium cone and plunger, same dim. as H-2520. Total wt. cone and plunger 30.0g.
Food products and paste paints	U.S. Dept. of Agriculture	H-2529	Aluminum. Same dimension as H-2520. Total wt. 35g.
(shortenings, margarine, butter, etc.) Measuring firmness of solid and plasticized fats	AOCS Cc 16-60	H-1270	10° aluminum cone, 3.2mm ferrule, 0.8mm stainless steel blunt tip. Overall length 106mm. Wt. 45g.
(i.e., recovery of used grease) Small obtainable samples	ASTM D1403	H-2519	1/4 scale. (Not considered a substitute for full-size cone specified in ASTM D217.) Wt. 9.38g.

**Penetration Needles and Cones**



H-1280  
H-1290  
H-1300  
H-1302



H-1310  
H-1317



H-1255



H-1320



H-1270



H-2519



H-2520  
H-2522  
H-2529



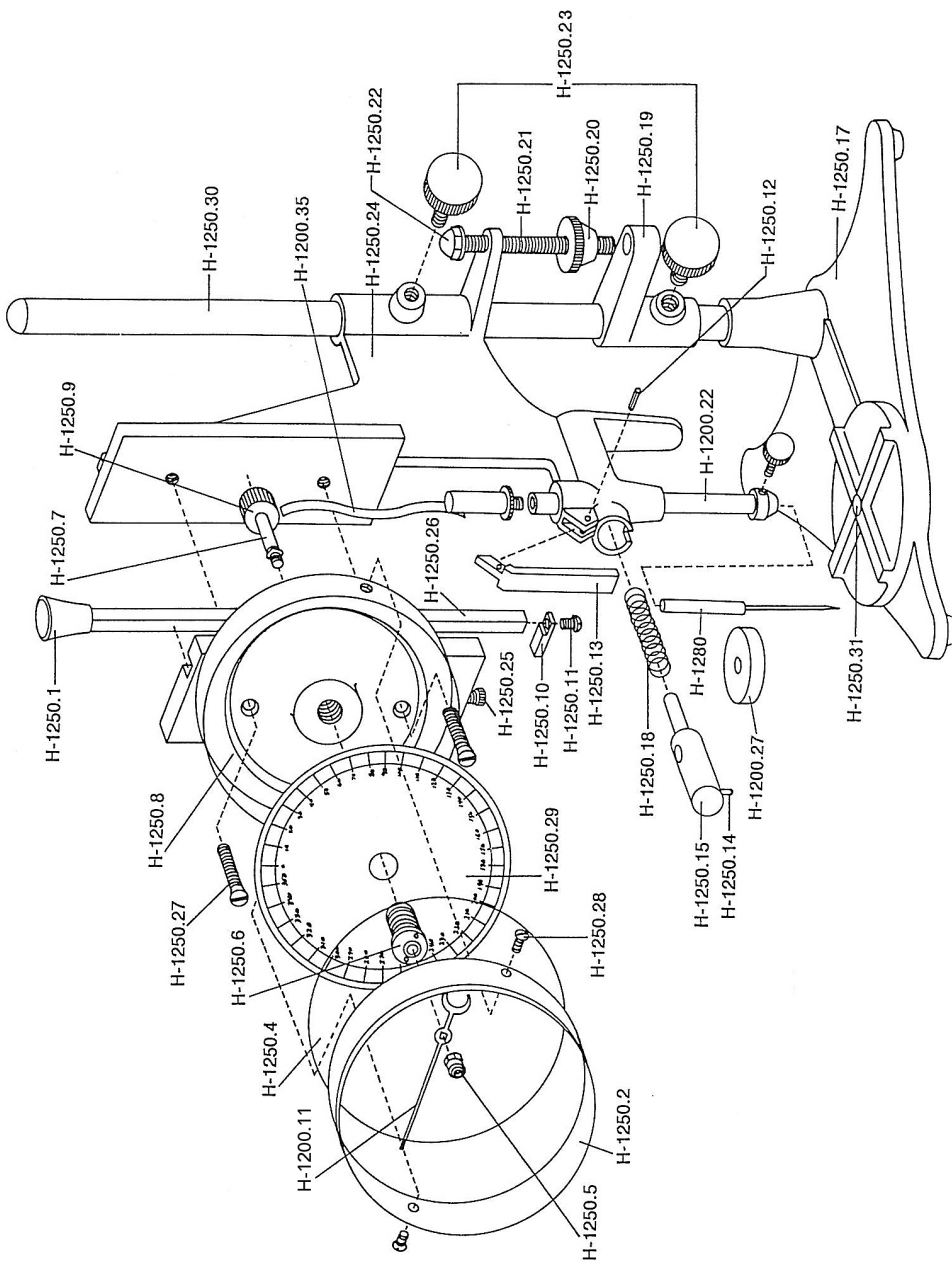

**H-1250**

## Warranty

Humboldt Mfg. Co. warrants its products to be free from defects in material or workmanship. The exclusive remedy for this warranty is Humboldt Mfg. Co., factory replacement of any part or parts of such product, for the warranty of this product please refer to Humboldt Mfg. Co. catalog on Terms and Conditions of Sale. The purchaser is responsible for the transportation charges. Humboldt Mfg. Co. shall not be responsible under this warranty if the goods have been improperly maintained, installed, operated or the goods have been altered or modified so as to adversely affect the operation, use performance or durability or so as to change their intended use. The Humboldt Mfg. Co. liability under the warranty contained in this clause is limited to the repair or replacement of defective goods and making good, defective workmanship.

### **Humboldt Mfg. Co.**

875 Tollgate Road  
Elgin, Illinois 60123 U.S.A.

U.S.A. Toll Free: 1.800.544.7220

Voice: 1.708.468.6300

Fax: 1.708.456.0137

Email: [hmc@humboldtmfg.com](mailto:hmc@humboldtmfg.com)

Testing Equipment for



Construction Materials

# HUMBOLDT

[www.humboldtmfg.com](http://www.humboldtmfg.com)