



H-1240 & H-1240.4F



Electric Penetrometer with Digital Automatic Timer

Testing Equipment for Construction Materials
HUMBOLDT
1.800.344.1700 • www.humboldtcorp.com • 714.865.4300

Introduction

The Humboldt Electric Automatic Penetrometer is of rugged construction, but requires careful handling to safeguard its accuracy. Keep the instrument clean at all times – especially the drop and indicator plungers, which constitute the spindle assembly. Use denatured alcohol as the cleaner for these surfaces.

For complete test procedure(s), refer to the following specifications: ASTM D5, D217, D937, D1168, D1321, D1403, D1831, and AASHTO T49.

Installation

1. Level the instrument carefully by means of the leveling screws on the base, sighting the spirit level from above, in order to obtain accurate alignment. After the instrument has been leveled, avoid shifting its location.
2. Position the height of the supporting casting by turning the knurled travel nut on the main support post and then tighten the black knob.
3. If additional weights are used, these should be taken from the side post and set on the end of the plunger (opposite end of the needle chuck).
4. Insert penetrating needle or cone into chuck and tighten the chuck screw.

Instruction

As supplied by Humboldt the unit is programmed to provide a solenoid actuation period (plunger release) of 5 seconds. The panel-mounted, electronic timer uses 120 VAC, 50/60 Hz. In order to use 240 VAC, a step-down transformer or converter suitable for digital circuits is required. The H-1240.4F is supplied with an H-1042 transformer for this purpose and is plug compatible with the penetrometer cap-plug, but requires the input line cord to the transformer to be wired for local service.

For further timer information refer to the ATC Model 365B Long Range Timer Instructions.

Operation

1. Holding the plunger with one hand, squeeze the lever on the front of the support casting with the other to allow raising the plunger & needle to clear the sample. Flip the toggle switch on the front panel to the up position and pre-select the specified time of penetration by turning the knobs on the timer bezel.
2. To conduct a test set the needle, cone or micro-cone on the sample surface. When ready to begin, press the red pushbutton on the front panel to release the plunger for the pre-selected amount time. The timer-controlled electromagnet will immediately release the plunger and after the preselected time interval will re-grip it to stop the test.
3. Measure the travel of the plunger assembly by lowering the dial indicator rod to contact the plunger and observing the dial reading.

- To reset for the next test, the front panel toggle switch must first be flipped to the down position, then the above sequence can be repeated.

CAUTION: Keep hands, clothing and other objects away from moving parts when the machine is in operation.

Drawing

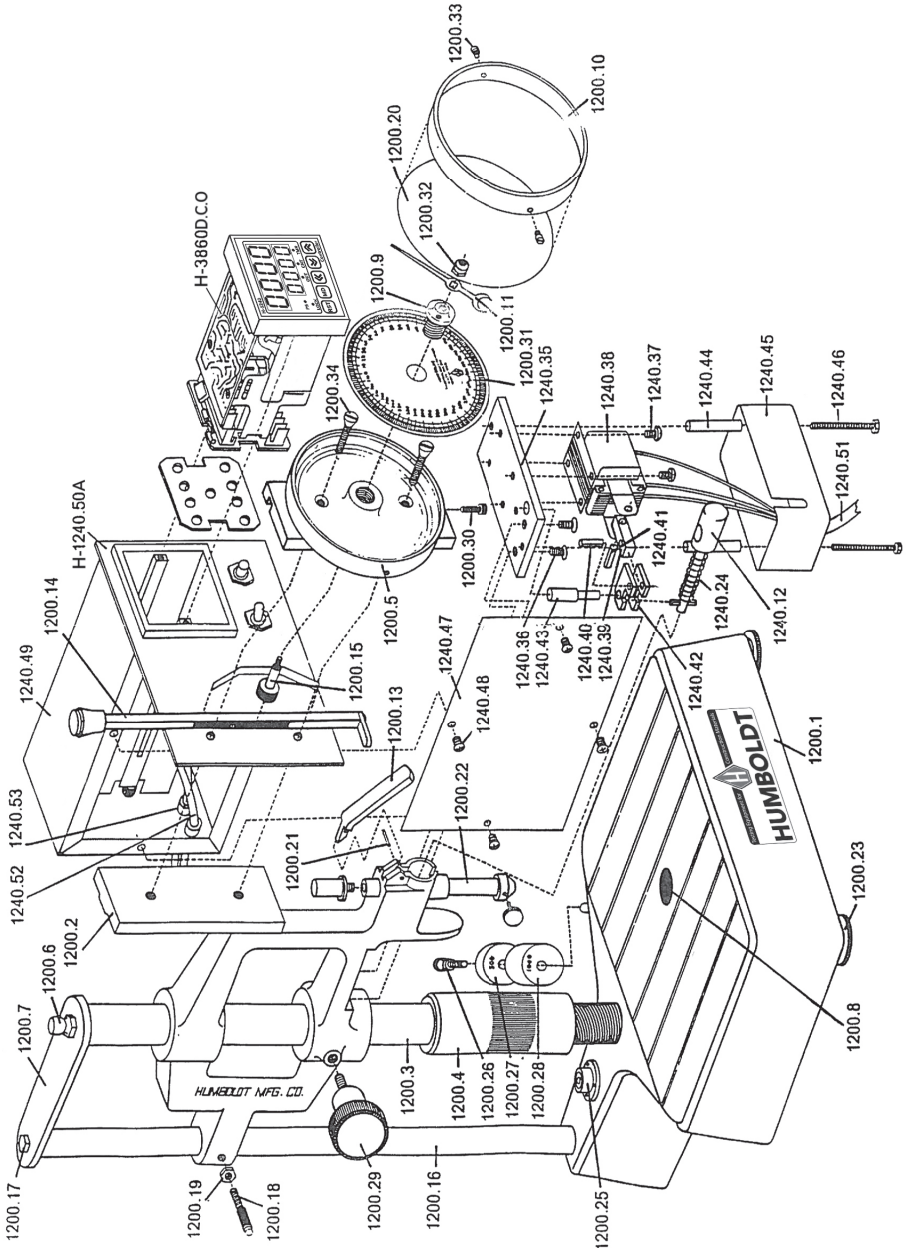

H-1240

Penetration Needles and Cones

Bituminous materials ASTM D5; AASHTO T49, IP49; ASA Std. A37.1; Fed Spec. SS.R. 406C, Meth. 214.01	Standard hardened stainless steel needle, 40-45mm exposed needle length. Wt. 2.5g.	H-1280
	Standard hardened stainless steel needle, 40-45mm exposed needle length. Certified to ASTM accuracy by independent laboratory. Wt. 2.5g.	H-1300
	Long hardened stainless steel needle, 50- 55mm exposed needle length. Wt. 2.5g.	H-1290
	Long hardened stainless steel needle, 50- 55mm exposed needle length. Certified to ASTM accuracy by independent laboratory. Wt. 2.5g.	H-1302
Waxes with 250 or less penetration ASTM D1321	Hardened stainless steel wax penetration needles with tapered point, blunt tip of truncated cone. Ferrule is approx. 3.2mm dia. Wt. 2.5g.	H-1310
	Same as H-1310. Certified to ASTM accuracy.	H-1317
Battery paste	Hardened stainless steel tip with special plunger. Total wt. 60g ± .050g.	H-1255
Joint sealant for asphalt & con- crete pavements ASTM D5329	Resilience ball penetration tool. Total wt. 27.5g.	H-1320
Measuring firmness of solid and plasti- cized fats: shorten- ings, butters AOCS Cc 16-60	20° aluminum cone, 3.2mm ferrule, 0.8mm stainless steel blunt tip. Overall length 106mm. Wt. 45g.	H-1270
Recovery of used grease, small samples ASTM D1403	1/4 scale. (Not considered a substitute for full-size cone specified in ASTM D217.) Wt. 9.38g	H-2519
Grease testing pen- etrometers ASTM D217, D937 ASA Std. Z11.3	Hollow 90° brass cone, highly polished stainless steel tip. Removable nut and stem. Wt. 102.5g.	H-2520
	Hollow 90° stainless steel cone, highly polished stainless tip. Removable nut and stem. Wt. 102.5g.	H-2522
ASTM D2884	Hollow 90° Magnesium cone and plunger. Total cone wt. 30.0g	H-2524
Food, Paste, Paints U.S. Dept of Agri- culture	Hollow 90° Aluminum cone and tip. Total wt. 35g	H-2529
Applications re- quiring 90° cones, ASTM D217, D937 ASA std. Z11.3	Stainless steel replacement tip, nut and stem.	H-2525

Penetration Needles and Cones



H-1280
H-1290
H-1300
H-1302



H-1310
H-1317



H-1255



H-1320



H-1270



H-2519



H-2520
H-2522
H-2529

Warranty

Humboldt Mfg. Co. warrants its products to be free from defects in material or workmanship. The exclusive remedy for this warranty is Humboldt Mfg. Co., factory replacement of any part or parts of such product, for the warranty of this product please refer to Humboldt Mfg. Co. catalog on Terms and Conditions of Sale. The purchaser is responsible for the transportation charges. Humboldt Mfg. Co. shall not be responsible under this warranty if the goods have been improperly maintained, installed, operated or the goods have been altered or modified so as to adversely affect the operation, use performance or durability or so as to change their intended use. The Humboldt Mfg. Co. liability under the warranty contained in this clause is limited to the repair or replacement of defective goods and making good, defective workmanship.

Humboldt Mfg. Co.
875 Tollgate Road
Elgin, Illinois 60123 U.S.A.

U.S.A. Toll Free: 1.800.544.7220
Voice: 1.708.468.6300
Fax: 1.708.456.0137
Email: hmc@humboldtmfg.com

Testing Equipment for



Construction Materials

HUMBOLDT

www.humboldtmfg.com