



H-1336D, H-1346D & H-1356D



Marshall
Mechanical
Compactors

Introduction

Humbolt's Standard-Duty, 4-inch automatic compactors ease sample preparation through automatic, mechanical compaction. These compactors can be adjusted to provide a set number of hammer blows and then shut off. All three models include the mechanical compactor, as well as a H-1334B automatic counter, oak pedestal, hammer and mold.

The H-1336D is a single-mold configuration, The H-1346D is a dual-mold configuration and the H-1356D provides a triple-mold configuration. All machines meet ASTM D6926, D5581 and AASHTO T245 and PTM705.

It is recommended to have additional mold and hammer assemblies for your compactor for ease of use. Hammers are available in three configurations: the standard H-1338A, a 4" flat foot used in the H-1336D with the stationary mold; H-1338B, a 4" tapered-foot hammer for use with the H-1346D and H-1356D rotating molds and, H-1338C, a 4" Hammer with a "Canadian" tapered foot for rotating molds.

Operating Instructions

For preparation of specimens and compaction procedures, see ASTM D5581 & AASHTO T245.

1. Remove pin from top of compaction hammer.
2. Lean hammer toward front of machine so as to disengage it from the chain. Lift hammer out of mold.
3. Lift mold holder (spring loaded) to remove the mold, base plate and collar.
4. Fill mold with mixture - follow ASTM D-5581 & AASHTO T-245 procedures.
5. Replace mold, base plate & collar by reversing step 3 above.
6. Replace hammer(s) and lower surcharge weight(s).
7. On the automatic triple compactor, to get same count for all three hammers, start the hammer on the right first.
8. To start the machine, plug the power supply cord into the power source, if an automatic model use the receptacle on the counter chassis and set the counter for the proper number. Actuate the power switch.

WARNING: All hammer compaction weights must be down before starting the compactor. To put the hammers in the down position hold the hammer weight then press the release pin down to release the weight and lower it to rest of the mold.

CAUTION: Keep hands, clothing and other objects away from moving parts when the machine is in operation.

Cleaning & Lubrication

- Keep all parts clean and lubricated. Clean molds and hammer feet thoroughly before each use. Make sure all mounting hardware is tight.
- After using the H-1346D or H-1356D compactors for several weeks clean as follows: Remove the bottom rotating chain guard and clean all asphalt from the chain and around the turntables. Grease if necessary. Replace guards before resuming operations. Cleanliness improves the operation.

- For Worm Gear Reducers operating in ambient temperatures of 20 degrees to 100 degrees Fahrenheit, use lubricant conforming to A.G.M.A. #7 Compounded.
- In addition to lubrication, the unit should have regular inspection to determine the tightness of bolts and screws, misalignment of connected shafts, oil leakage, excessive heating or any unusual noise or vibration.

Approved Lubricants

Manufacturer	Worm Gears A.G.M.A. #7 Compounded
Chevron Oil Co.	Cylinder Oil 460X
Gulf Oil Co.	Transgear EP 460
Mobile Oil Corp.	600 W Cylinder Oil

Lift Chain Replacement

1. Remove back chain guard and broken lift chain.
2. Loosen screws on adjustment blocks.
3. Remove master link from new chain.
4. Assemble chain on H-1336D compactor with open ends at rear.
5. Put master link above the roller and pin (see drawing H-1336D).
6. Tighten chain tension as you would on a bicycle, by lifting adjustment blocks, tighten screws.
7. Put guard on and resume work.

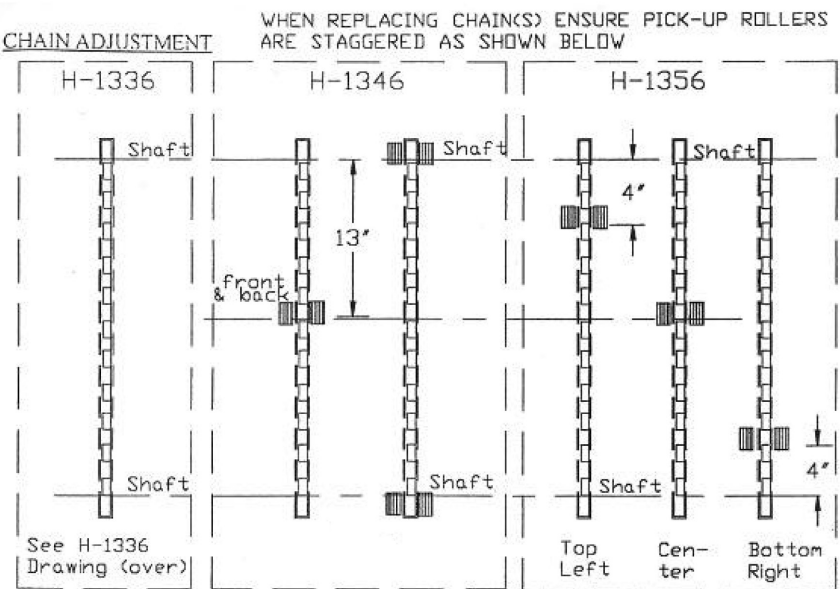

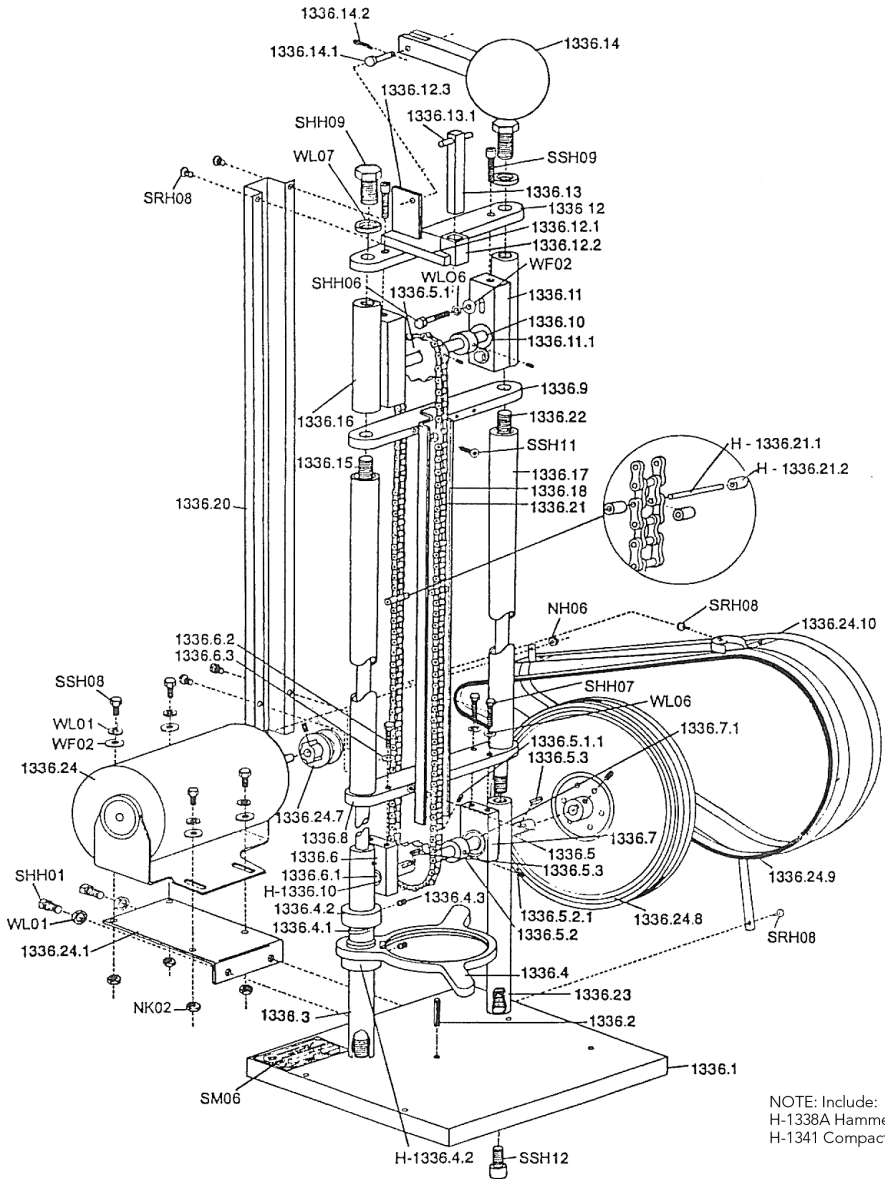

NOTE: Include:
 H-1336A Hammer Assy.
 H-1341 Compaction Mold

H-1336D

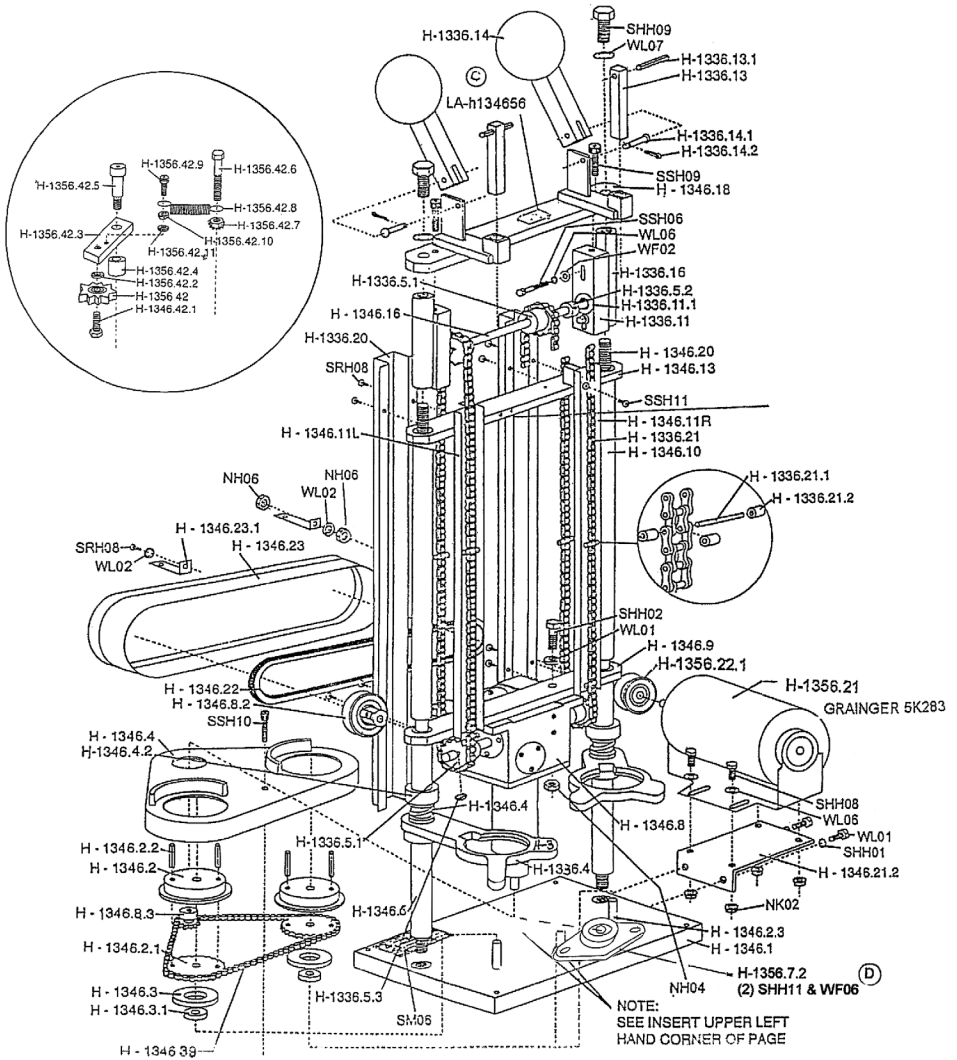

H-1346D

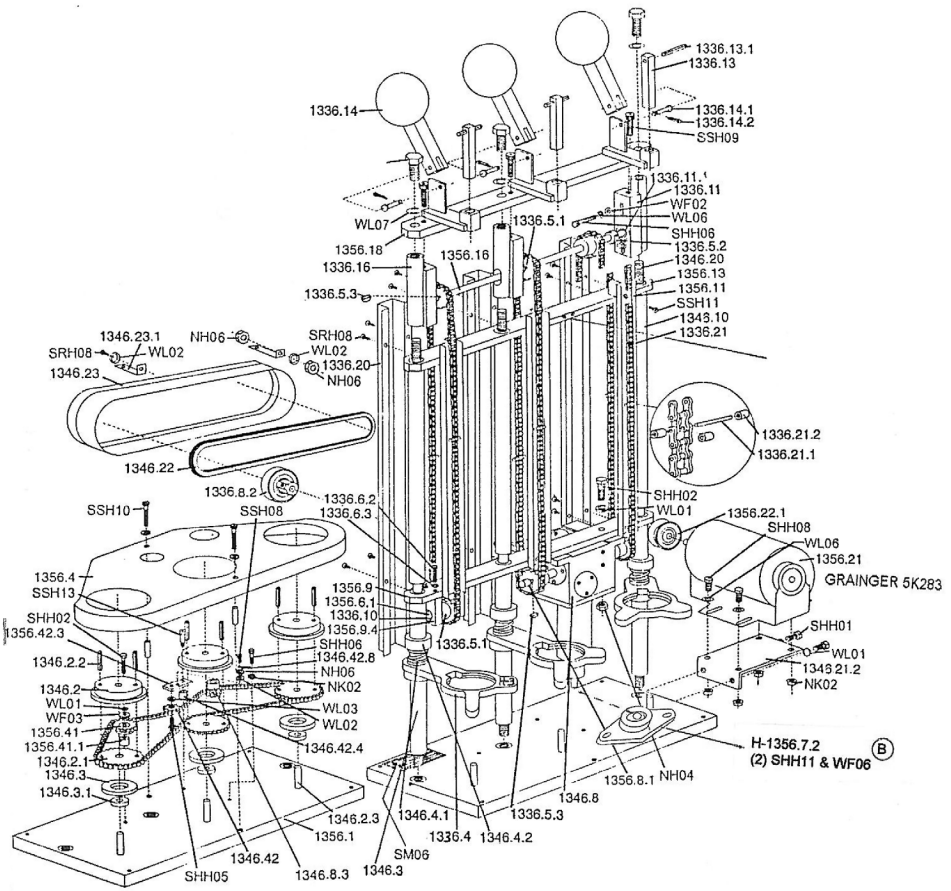

H-1356D

Hammer Replacement Parts

Description	Model
Clevis pin with screw	H-1338.29
Locator guide	H-1338.25
Hex head bolt	H-1338.25.1
Washer	H-1338.25.2
Nut	H-1338.25.3
Spacer	H-1338.25.4
Hammer handle	H-1338.26
Spring pin	H-1338.26.1
Hammer rod	H-1338.27
Key	H-1338.27.1
Hammer weight (complete)	H-1338.32
Plug	H-1338.33
Spring	H-1338.34
Hammer foot, flat	H-1338.35
Hammer foot, tapered	H-1338.38
Hammer foot, Canadian spec	H-1338.39
Screw for foot	H-1338.35.1

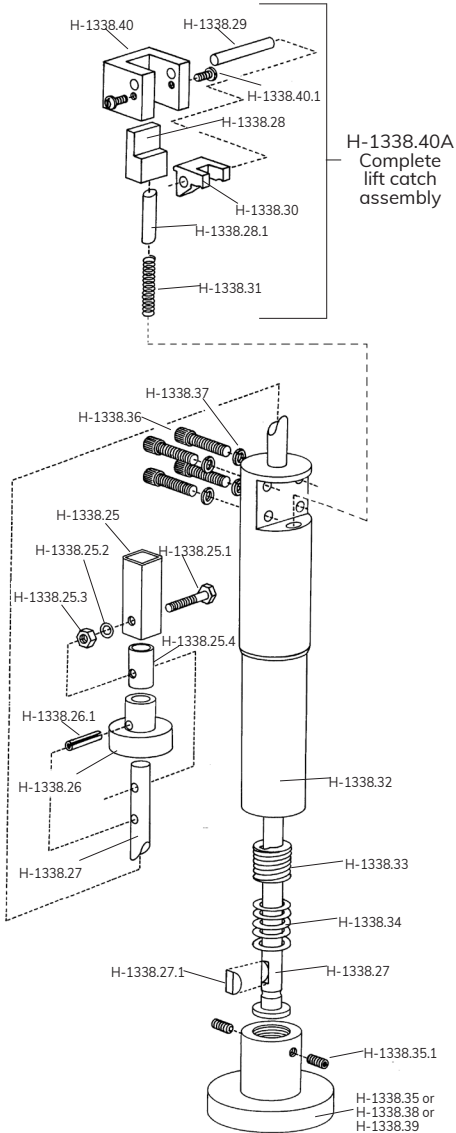

Lift Catch Replacement Parts

Description	Model
Complete lift catch assembly	H-1338.40A
Release block	H-1338.28
Pin	H-1338.28.1
Clevis pin	H-1338.29
Lift catch	H-1338.30
Spring	H-1338.31
Screw	H-1338.36
Washer	H-1338.37
Release housing	H-1338.40
Screw for release housing	H-1338.40.1

Warranty

Humboldt Mfg. Co. warrants its products to be free from defects in material or workmanship. The exclusive remedy for this warranty is Humboldt Mfg. Co., factory replacement of any part or parts of such product, for the warranty of this product please refer to Humboldt Mfg. Co. catalog on Terms and Conditions of Sale. The purchaser is responsible for the transportation charges. Humboldt Mfg. Co. shall not be responsible under this warranty if the goods have been improperly maintained, installed, operated or the goods have been altered or modified so as to adversely affect the operation, use performance or durability or so as to change their intended use. The Humboldt Mfg. Co. liability under the warranty contained in this clause is limited to the repair or replacement of defective goods and making good, defective workmanship.

Humboldt Mfg. Co.
875 Tollgate Road
Elgin, Illinois 60123 U.S.A.

U.S.A. Toll Free: 1.800.544.7220
Voice: 1.708.468.6300
Fax: 1.708.456.0137
Email: hmc@humboldtmfg.com

Testing Equipment for



Construction Materials

HUMBOLDT

www.humboldtmfg.com