



# H-2911 — H-2919



## Compressometers / Extensometers

# Introduction

## Compressometer

The Compressometer is used for evaluating deformation and strain characteristics of concrete cylinders while undergoing compression testing. The Compressometer includes two cast aluminum-alloy yokes, mounting and central points, stainless steel control rods. Models are available with a dial gauge— with a range of 0.2" (5.08mm) and minimum graduations of .0001 (.0025mm), as well as with a digital indicator or a LSCT transducer. Digital indicators and LSCT models can be used with data acquisition systems through the use of our MiniLoggers, see below. Meets ASTM C469. Shipping wt. 22 lb (10kg).

Compressometers	Dial Gauge	Digital Indicator	LSCT
6" x 12" (152 x 305mm) cylinders	H-2911	H-2911D	H-2911L
4" x 8" (102 x 203mm) cylinders	H-2916	H-2916D	H-2916L
3" x 6" (76 x 152mm) cylinders	H-2918	H-2918D	H-2918L

## Compressometer-Extensometer

Combined compressometer and extensometer for 6" dia. x 12"L (152 x 305mm) concrete cylinders is a convenient unbounded device. Apparatus contains a third yoke located halfway between the two compressometer yokes and attached to the specimen at two diametrically opposite points. Middle yoke is hinged to permit rotation of the two segments of the yoke in the horizontal plane. Indicator gives deformation readings. Second indicator is furnished for compressometer section. Unit measures changes in length and diameter. All H-2900 Series Compressometers may be ordered with dial gauges, digital indicators or strain transducers, see chart below. Digital Indicators and strain transducers can be used to construct a data acquisition system using our HM-2325A.3F and HM-2330D.3F MiniLoggers. Complies with ASTM C469.

Compressometer / Extensometers	Dial Gauge	LSCT
6" x 12" (152 x 305mm) cylinders	H-2912	H-2912L
4" x 8" (102 x 203mm) cylinders	H-2917	H-2917L
3" x 6" (76 x 152mm) cylinders	H-2919	H-2919L

The Concrete Cylinder Compressometer-Extensometer is used to determine the static modulus of elasticity (Young's Modulus) and Poisson's ratio of concrete in compression. The instrument complies with the specifications of ASTM C469. Using the H-2912, measurement of axial deformation and diametrical extension can be made on 6" dia x 12" to 16" length, high-molded concrete cylinders and diamond-drilled concrete cores, when longitudinal compressive stress is applied on the specimens. The device is constructed of lightweight aluminum magnesium alloy. The mounting points and contact points are of machine steel. The control (spacer rods) is stainless steel.

The axial and diametrical deformations can be read on the H-4460 & H-4461 dial indicators by taking one-half of their indicated values. (The lever ratio of the instrument multiplies the deformation by the factor 2\*, therefore, actual deformation of the specimen is one-half the indicated value).

The dial indicators have an operating range of 0.2 in. graduated in 0.0001 in. divisions that are separated enough to read in between them to the nearest  $\frac{1}{2}$  division or 0.000050 in. dividing this by 2 to account for the lever ratio gives 0.000025 in. deformation.

Strain is then computed by dividing by the effective specimen gage length, 6 in. for diameter and 8 in. for axial, giving readability better than 5 micro in per in per in strain required by ASTM C-469. Three metal blocks are recommended to enable the operator to conveniently mount the instrument at mid height on the concrete cylinder.

For preparation of the specimen and detailed test procedure refer to ASTM C469.

## **Assembly**

- 1 Place the concrete cylinder upright.
- 2 Assemble H-2912 as shown in the drawing. The H-4461 dial indicator with the stem brake should be mounted in the vertical position. The other dial indicator H-4460 should be mounted horizontally.
- 3 Unscrew the seven contact screws (2 on the upper lock ring, 3 on the lower lock ring and 2 on the middle ring) until the points are flush with the inside surface of the rings.
- 4 Place the compressometer over the concrete specimen locating the specimen at the center of the ring.
- 5 Place three equal length blocks under the lower ring. The length of the blocks (cylinders) should be vertical to provide the correct height.
- 6 Hand-tighten the 3 contact screws in the lower lock ring. And the 2 contact screws in the upper ring against the specimen.
- 7 Also hand-tighten the 2 contact screws in the middle ring making sure that the vertical stem of the axial strain dial indicator is midway between the two portions of the middle ring.
- 8 Remove the two spacer rods

- 9 Remove the three metal blocks from under the lower ring.
- 10 Zero the axial strain dial indicator with the stem close to the fully extended position. Zeroing can be done (1) by rotating the dial face after loosening the lock screw on the upper right hand side of the dial indicator or (2) by adjustment of the contact post that fits into the lower lock ring.
- 11 Zero the diametrical strain dial indicator with its stem close to the fully pushed-in position. (The stem is going to extend by the diametrical deformation of the specimen). Zeroing of the dial can be done by rotating the dial face or by adjusting the contact point.

### Calculation

- 1 To Calculate the modulus of elasticity, to the nearest 50,000 psi (344.74 MPA) as follows:

$$E = (S_2 - S_1) / (\epsilon_2 - 0.000050) \text{ Where:}$$

E = chord modulus of elasticity, psi

S<sub>2</sub> = stress corresponding to 40 percent of ultimate load or corresponding to appropriate strain value from Table 1 (below), psi

S<sub>1</sub> = stress corresponding to a longitudinal strain,  $\epsilon_1$ , of 50 millionths, psi

$\epsilon_2$  = longitudinal strain produced by stress S<sub>2</sub>.

- 2 To Calculate the poisson's ratio, to the nearest 0.01 as follows:

$$\mu = (\epsilon_{t2} - \epsilon_{t1}) / (\epsilon_2 - 0.000050)$$

Where:

$\epsilon_{t2}$  = transverse strain at midheight of the specimen produced by stress S<sub>2</sub>.

$\epsilon_{t1}$  = transverse strain at midheight of the specimen produced by stress S<sub>1</sub>.

**Table 1: Maximum Strain Values**

Unit Weight @ Time of Test		Strain @ Age Indicated, Max. Millionths	
lb/ft <sup>3</sup>	CK/M <sup>3</sup>	7 Days or More	Less Than 7 Days
205	3280 and Over	300	200
165 to 204	2640 to 3264	375	250
135 to 164	2160 to 2624	450	300
115 to 134	1840 to 2144	525	350
105 to 114	1680 to 1824	600	400
95 to 104	1520 to 1664	675	450
85 to 94	1360 to 1504	750	500
75 to 84	1200 to 134	825	550

## Maintenance

- 1 Occasionally oil the steel portions of the instrument, screws, spacer rods, nuts, etc.
- 2 Care should be taken in handling the device in order to avoid any misalignment of parts.



HCM-5090.3F



HM-2310.04



HM-4177

## Data Acquisition Upgrade for Existing Compression Machines and Compressometer-Extensometer Testing

Looking to upgrade your existing manually-operated compression machine or add compressometer/extensometer testing capabilities to it? Now you can easily upgrade your frame with Humboldt's HCM-5090 Digital Indicator. The HCM-5090's four, independent data acquisition channels provide you with enough options to control all your data needs with one digital indicator.

A typical setup would provide the logging of Load, Stress and Rate from one compression machine in Channel One. Channels Two and Three would provide inputs for measuring displacement— allowing you to per-

form extensometer and compressometer testing. Channel Four would provide another input for logging Load, Stress and Rate, perfect for an additional load frame set up for something like flexural testing or cubes. All this information can be simultaneously tracked by the HCM-5090.3F.

### Strain Transducer

ASTM C469

Strain transducer: 0.4" (10mm)

Strain Transducer

HM-2310.04



Ship wt. 1lbs. (453g)

### Pressure Transducer

Pressure transducer: 10,000 psi with plug for HCM-5090.3F

Pressure Transducer

HM-4177



Ship wt. 1lbs. (453g)

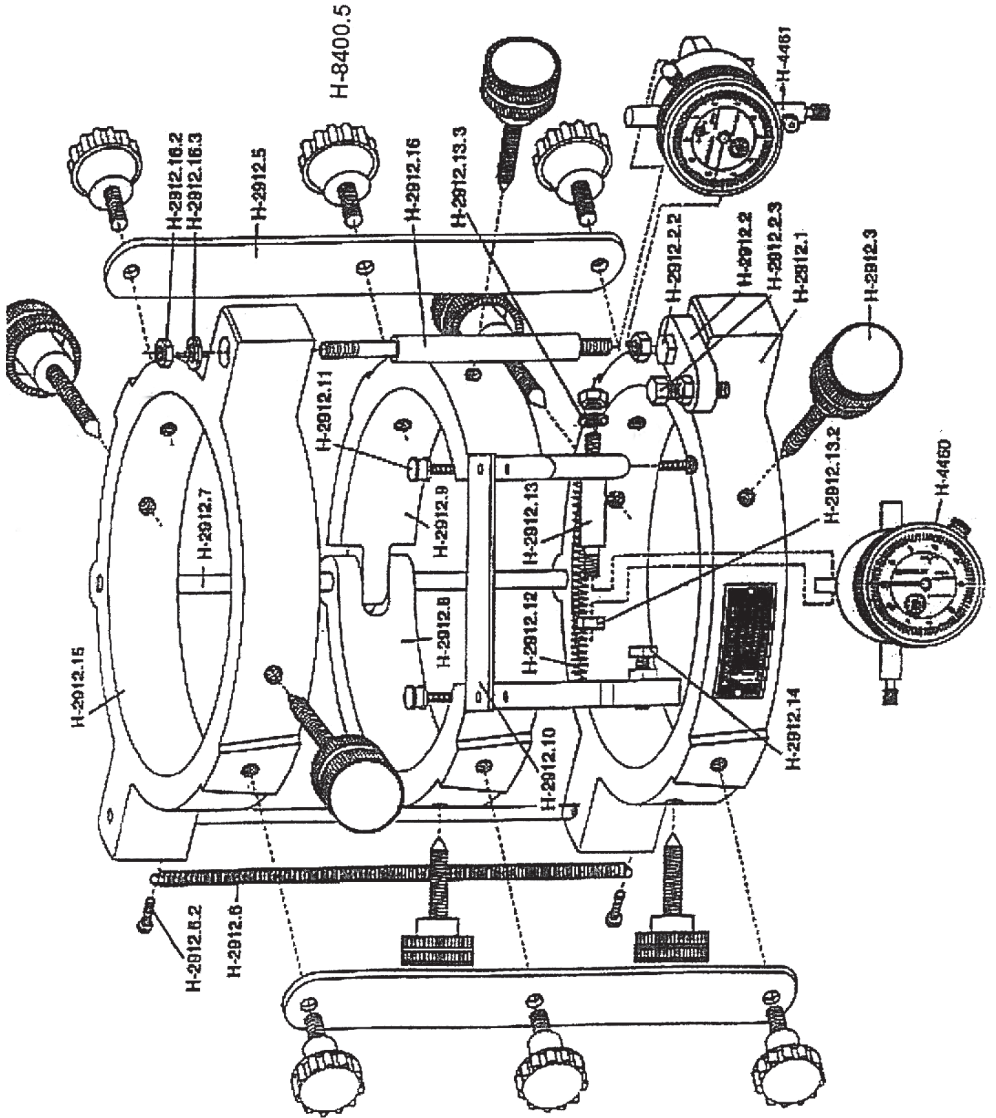

**Parts Drawing For H-2912**



## Warranty

Humboldt Mfg. Co. warrants its products to be free from defects in material or workmanship. The exclusive remedy for this warranty is Humboldt Mfg. Co., factory replacement of any part or parts of such product, for the warranty of this product please refer to Humboldt Mfg. Co. catalog on Terms and Conditions of Sale. The purchaser is responsible for the transportation charges. Humboldt Mfg. Co. shall not be responsible under this warranty if the goods have been improperly maintained, installed, operated or the goods have been altered or modified so as to adversely affect the operation, use performance or durability or so as to change their intended use. The Humboldt Mfg. Co. liability under the warranty contained in this clause is limited to the repair or replacement of defective goods and making good, defective workmanship.

### **Humboldt Mfg. Co.**

875 Tollgate Road  
Elgin, Illinois 60123 U.S.A.

U.S.A. Toll Free: 1.800.544.7220

Voice: 1.708.468.6300

Fax: 1.708.456.0137

Email: [hmc@humboldtmfg.com](mailto:hmc@humboldtmfg.com)

Testing Equipment for



Construction Materials

# HUMBOLDT

[www.humboldtmfg.com](http://www.humboldtmfg.com)