



Concrete Rebound Hammer

Using the Humboldt Concrete Rebound Hammer

Always hold the Concrete Rebound Hammer in both hands while in use. Also, when in use, keep the hammer perpendicular to the surface you are testing with the scale pointing up, making it easier to read.



Figure 1: The Concrete Rebound Hammer

Before the Hammer can be used for testing, the piston must be released out of the hammer into the testing position. Typically during storage and transportation, the Hammer piston will be locked inside the Rebound Hammer and will need to be released from the storage position. If the piston is not extended into the test position, place the end of the piston against a stiff surface and gently press the Rebound Hammer firmly against the surface. You will hear a click, and the piston will extend into the test position.



Figure 2: Always hold the Rebound Hammer with both hands perpendicular to the surface



Figure 3: Push the piston in as far as it will go

To perform a test, make sure the piston is extended and gently press the Rebound Hammer against the concrete surface to be tested. When the piston is pressed all the way into the Rebound Hammer, continue to push harder until you hear a rattling sound. Keep the Rebound Hammer firmly pressed against the concrete surface and read the rebound number on the scale.

As long as you hold the Rebound Hammer firmly against the concrete, the rebound number will remain on the scale. Record your reading. When you pull the hammer away and allow the piston to re-extend, the scale will return to zero.

The Rebound Hammer is now ready for another test. If desired, once you get a reading, you may press the button on the handle to lock the piston in place. This makes your test results easier to read, as it will also lock the indicator. Do not touch the button until you get a reading. To release the piston again for the next test, press against a hard surface. When you are finished using the Rebound Hammer, lock the piston inside the Rebound Hammer for storage, as described above.

Taking a Measurement

Selecting a Surface for Testing

Select a concrete surface that is:

- Smooth, dry, and fixed in place
- At least 4 inches (or 102 mm) thick
- Mature— at least 14 days old
- Free of any decay or scaling

If necessary grind a section of rough concrete smooth before taking your readings. A grind stone in a plastic case is provided with the hammer for this purpose.

Surfaces to Avoid

Avoid testing concrete that is:

- Frozen
- Honeycombed or excessively porous
- Known to have rebar 2cm or less below the surface
- Carbonated on the surface

If you must test a mature concrete surface that is damp from rain or flowing water, or if you must test new concrete, keep in mind that you will probably get rebound numbers that are lower than they should be. Using the Rebound Hammer on new concrete may damage it if the strength is less than 1,000 PSI.

If you are testing concrete with a lot of surface carbonation, the rebound readings will be significantly higher than normal. The thicker the layer of carbonated concrete, the higher the rebound numbers.

Holding the Rebound Hammer against Walls, Ceilings, and Floors

The Rebound Hammer will work against any concrete surface as long as you keep it perpendicular to that surface. The Rebound Hammer can be used against a ceiling (upward), a floor (downward), or a wall (forward). You will need to consider gravity when estimating the compressive strength of concrete. The rebound number found when pressing up against a ceiling will differ from the number that appears if you are pressing down against a floor. Please review the strike angles A, B, and C and the correlation curves in “Reading your Results” below.

Specialty Concrete

The Rebound Hammer is designed to estimate the compressive strength of standard concrete. The correlation diagram for standard concrete is printed on the side of your Concrete Rebound Hammer. It shows the correlation curves determined when the compressive strength of standard concrete, as measured with your Rebound Hammer, is directly compared to the compressive strength from laboratory tests of concrete cylinders or cubes.

This diagram is not designed for use with:

- Light weight concrete
- Concrete using artificial aggregates
- High performance concrete

In order to gain an accurate rebound number for these specialty materials, you will need to create your own correlation curves diagram intended for this use. See the standards ACI 228.1R-2010 and ASTM C-805-08.

Reading your Results

Make at least ten readings from a concrete surface and discard the highest and lowest rebound numbers. Average the remaining eight numbers. If desired, take a few test readings before you complete your series of ten regular tests. Use the average rebound number to estimate the strength of the concrete. Compare your average rebound number to the chart shown on your Concrete Rebound Hammer. Consider the diagram shown here:

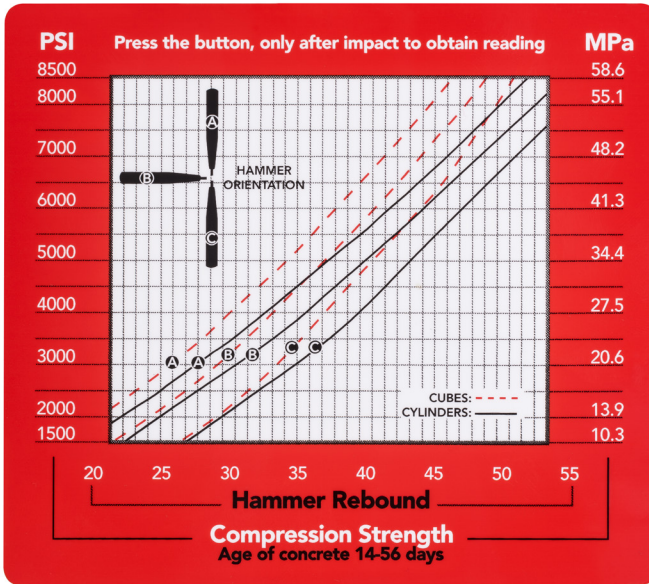

Figure 4: Concrete Rebound Hammer correlation curves

Rebound Number

Correlation curves. This diagram shows the relationship between the compressive strength for concrete, measured directly in a laboratory using concrete cylinders or concrete cubes, and the rebound numbers you receive using your Rebound Hammer.

A refers to using the Rebound Hammer against a concrete floor (downward).

B refers to using it against a concrete wall (forward).

C refers to using it against a concrete ceiling (upward).

The strength values shown in this diagram are directly based on compressive strength testing in a laboratory, using concrete 14 to 56 days old. The tests use concrete cylinders, 6 inches wide and 12 inches high (15cm x 20cm), or concrete cubes six inches high.

According to ASTM C-805-08, you should discard any readings that differ from the average value rebound number by more than six units. Then, take an average for the remaining readings. If more than two readings differ by more than six units from the average value, throw out all of your readings and perform the test over again. Take ten new readings with your Rebound Hammer in a

different section of the concrete but in the same test area.

Note that some countries have set their own national standards for calculating test results. Therefore, follow the standards of the country where you are using your Rebound Hammer.

Maintenance

We recommend that you calibrate your Rebound Hammer regularly using the Humboldt Calibration Anvil, H-2972, ordered separately. For a Rebound Hammer, you should start verifying the readings after approximately 2,000 uses (or completed tests). You should also verify the readings if you have reason to suspect that your Rebound Hammer is giving you false data.

Verifying Performance of Rebound Hammer

When tested against the Anvil, the rebound number must be a value of 80 ± 2 . As the Rebound Hammer approaches 2,000 uses, it may start to read outside of the range of 80 ± 2 on the test Anvil. At this point an inspection by our service center is suggested.

Safety:

- When using this device wear safety glasses
- Do not fire the Rebound Hammer against any body part

Specifications:

Humboldt Concrete Rebound Hammer: H-2987H

Weight: 2lbs (0.9 kilograms)

Size: 10.5" (267mm) with plunger retracted

Shipping weight: Six pounds (2.7 kilograms)

Carrying case: 15½ inches x 11½ inches x 2½ inches

H-2987H Replacement Parts

Key	Description	Part#
1	Impact Plunger	H-2987.1
3	Housing, complete	H-2987.3
4	Rider with Guide Rod	H-2987.4
6	Push-button, complete	H-2987.6
7	Hammer Guide Bar	H-2987.7
8	Guide Disk	H-2987.8
9	Cap	H-2987.9
10	Two-part Ring	H-2987.10
11	Rear Cover	H-2987.11
12	Compression Spring	H-2987.12
13	Pawl	H-2987.13
14	Hammer Mass	H-2987.14
15	Retaining Spring	H-2987.15
16	Impact Spring	H-2987.16
17	Guide Sleeve	H-2987.17
18	Felt Washer	H-2987.18
19	Acrylic Window	H-2987.19
20	Trip Screw	H-2987.20
21	Lock Nut	H-2987.21
22	Pin	H-2987.22
23	Pawl Spring	H-2987.23

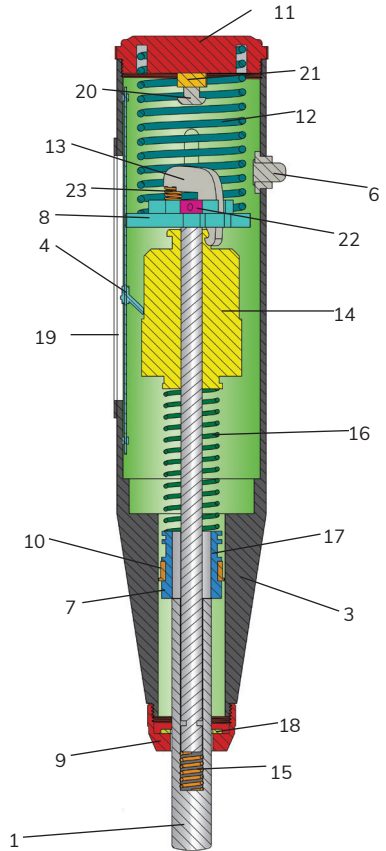

Warranty

Humboldt Mfg. Co. warrants its products to be free from defects in material or workmanship. The exclusive remedy for this warranty is Humboldt Mfg. Co., factory replacement of any part or parts of such product, for the warranty of this product please refer to Humboldt Mfg. Co. catalog on Terms and Conditions of Sale. The purchaser is responsible for the transportation charges. Humboldt Mfg. Co. shall not be responsible under this warranty if the goods have been improperly maintained, installed, operated or the goods have been altered or modified so as to adversely affect the operation, use performance or durability or so as to change their intended use. The Humboldt Mfg. Co. liability under the warranty contained in this clause is limited to the repair or replacement of defective goods and making good, defective workmanship.

Humboldt Mfg. Co.

875 Tollgate Road
Elgin, Illinois 60123 U.S.A.

U.S.A. Toll Free: 1.800.544.7220

Voice: 1.708.456.6300

Fax: 1.708.456.0137

Email: hmc@humboldtmfg.com

Testing Equipment for



Construction Materials

HUMBOLDT

www.humboldtmfg.com