



H-3052A.3F

Product Manual



Vicatronic Auto Vicat

Contents

1. GENERAL INFORMATION.....	4
1.1 WARNINGS.....	4
1.2 WARNING AND DANGER INDICATIONS - SIGNS.....	4
1.3 AIM OF THE INSTRUCTIONS MANUAL.....	4
1.4 STRUCTURE OF THE INSTRUCTIONS MANUAL.....	4
1.5 COMPOSITION OF THE INSTRUCTIONS MANUAL.....	5
1.6 MODIFICATIONS AND ENCLOSURES OF THE INSTRUCTIONS MANUAL.....	5
1.7 CONSTRUCTOR IDENTIFICATION.....	5
1.8 MACHINE IDENTIFICATION DATA.....	5
1.9 EC STAMP.....	5
1.10 USAGE.....	5
1.11 OPERATORS.....	5
1.12 STORAGE.....	6
1.13 TRASPORTATION AND MOVEMENT.....	6
1.14 PACKAGING REMOVAL.....	6
2. TECHNICAL CHARACTERISTICS.....	6
2.1 GENERAL MACHINE DESCRIPTION.....	6
2.2 DIMENSIONS AND WEIGHT.....	7
2.3 POWER SUPPLY.....	7
2.4 NOISE.....	7
3. GENERAL SAFETY STANDARDS.....	8
3.1 GENERAL STANDARDS.....	8
3.2 MACHINE SAFETY DEVICES AND PROTECTION.....	8
3.3 ACTIVE SAFETY DEVICES.....	8
3.4 DANGEROUS PARTS AND RESIDUAL RISK.....	8
4. INSTALLATION INSTRUCTIONS.....	9
4.1 LOCATION.....	9
4.2 ASSEMBLING PROCEDURE.....	9
4.3 ELECTRICAL CONNECTIONS.....	9
5. MAN-COMMAND INTERFACE.....	9
5.1 WORKPLACE.....	9
5.2 DESCRIPTION OF SCREENS AND SOFTWARE'S FUNCTIONS.....	10
6. MACHINE REGULATION AND TUNING.....	19
6.1 REGULATIONS.....	19
7. IN FUNCTION - USE.....	20
7.1 MACHINE CALIBRATION – METERS - INDICATORS.....	20
7.2 SWITCHING ON.....	20

7.3	EQUIPPING.....	20
7.4	SAMPLE POSITIONING.....	21
7.5	SWITCHING THE APPLIANCE ON	21
7.6	NORMAL STOP.....	21
7.7	EMERGENCY STOP.....	21
7.8	START UP AFTER EMERGENCY.....	21
7.9	START UP AFTER STOP COMMANDED BY SAFETY CIRCUIT.....	21
7.10	SWITCHING OFF	21
7.11	TEST START UP.....	21
8.	MAINTENANCE.....	26
8.1	ORDINARY MAINTENANCE.....	26
8.2	EXTRAORDINARY MAINTENANCE	26
8.3	AUTHORIZED MAINTENANCE CENTRES.....	27
9.	GUIDE TO RECOGNISING DAMAGE AND ANOMALIES	27
10.	SPARE PARTS.....	28
11.	INACTIVITY	28
12.	DECOMMISSIONING THE MACHINE.....	28
13.	ELECTRICAL DRAWINGS	29

1. GENERAL INFORMATION

1.1 WARNINGS

The manufacturer does not accept any responsibility for direct or indirect damage to people, things or animals and use of the appliance in different conditions from those foreseen.

The manufacturer reserves the right to make changes to the documentary information or to the appliance without advance notice.

Check the machine responds to the standards in force in the state in which it has been installed.

All operations necessary for maintaining machine efficiency before and throughout use are the operator's responsibility. Carefully read the entire manual before operating the machine.

It is vital to know the information and limitations contained in this manual for correct machine use by the operator. Interventions are only permitted if the operator is accordingly competent and trained.

The operator must be knowledgeable about machine operations and mechanisms.



The purchaser must ensure that operators are trained and aware of all the information and clarifications in the supplied documentation. Even with such certainty the operator or user must be informed and therefore aware of potential risks when operating the machine. Safety, reliability, and optimum performance is guaranteed when using original parts.

Any tampering or modifying of the appliance (electrical, mechanical or other) which has not been previously authorised in writing by the manufacturer is considered abusive and disclaims the constructor from any responsibility for any resulting damage. All necessary operations to maintain the efficiency of the machine before and throughout use are the responsibility of the user.

1.2 WARNING AND DANGER INDICATIONS - SIGNS

The machine has been designed and constructed according to the current norms and consequently with mechanical and electrical safety devices designed to protect the operator or user from possible physical damage. Residual risks during use or in some intervention procedures on the device are however present. Such risks can be reduced by carefully following manual procedures, using the suggested individual protection devices, and respecting the legal and safety norms in force.

This manual includes "Warning" and "Danger" indications in relevant chapters. These indications are shown with the words "Danger" or "Warning" in bold font and uppercase to make them highly visible.

	WARNING	It indicates that machine damage could be caused should indications be ignored.
	DANGER	It indicates that machine damage and/or injury to the worker could be caused should indications be ignored.

"**DANGEROUS ZONE**" indicates any zone inside or in the proximity on the appliance in which a person is exposed to the risk of injury or damage to health.

1.3 AIM OF THE INSTRUCTIONS MANUAL

This manual has been edited with the aim of providing all machine operators with all the necessary information on installation, use and maintenance from production to scrapping in as comprehensive and clear manner as possible.

All the procedures useful for any foreseeable emergency situations have been listed by the manufacturer and can be verified during use.

Operators, for whom this manual has been written, due to their competence must give instructions or operate the machine themselves.

The instructions manual must be carefully consulted by laboratory or site safety managers, equipment operators and any internal and external maintenance workers.

The manual is integral to the product and refers to this appliance only.

The manual must be safeguarded and always kept near the equipment so that it can be easily consulted whenever necessary.

IMPORTANT: The manual does not substitute the experience and technical training of the worker but must be considered a guide for carrying out its functions.

Furthermore, all the norms and rules the operator should be aware of or consult for correct use of the machine and/or test performance can be found in the manual.

This responsibility is entrusted to the installer and Laboratory or Site Manager where the machine is installed. The Constructor is available to provide further information.

1.4 STRUCTURE OF THE INSTRUCTIONS MANUAL

The manual can consist of a number of documents, as shown in the appropriate list.

- Correctly train and educate the “QUALIFIED PERSONNEL” before allowing them access to the machine. The personnel must also be exhaustively trained with regards to the machine’s protection devices.
- Ensure the machine’s safety devices are not tampered with or removed and are checked daily. Provide the operator appropriate individual protection devices according to the laws in force.
- The constructor is available for clarification, assistance and training and declines all responsibility for damage to things or people resulting from improper, incorrect, and negligent use by untrained personnel.

1.12 STORAGE

	WARNING	The appliance must be stored and conserved in the original packaging and in a closed environment, protected from atmospheric agents with a minimum temperature of 5C°, and a maximum of +40C° and a maximum humidity of 70%.
---	----------------	--

1.13 TRASPORTATION AND MOVEMENT

	WARNING	To avoid irreparable machine damage, move with care, do not overturn, protect from rain, do not stack, protect the packaging and its contents from bumps and sources of heat.
---	----------------	---

During transportation and movement, it is important to avoid bumps, overloading with other packages, exposure to freezing or heating atmospheric agents, or any other potentially harmful condition to the device, things or people.

1.14 PACKAGING REMOVAL

After removing the packaging check the machine is complete and that there are no visibly damaged parts. **DO NOT USE THE MACHINE** and refer to the constructor when in doubt.

	DANGER	The components used for packaging (plastic bags, polystyrene, nails, screws, wood, etc) must be kept out of reach of children, as they are sources of danger. These components should be placed in the appropriate containers.
---	---------------	--

	WARNING	In order to avoid bumps and overturn adopt the normal and logical precautions. Before disposing of the packaging check all machine components such as accessories, utensils, instructions, documents etc have been removed.
--	----------------	---

2. TECHNICAL CHARACTERISTICS

2.1 GENERAL MACHINE DESCRIPTION

The Vicatronic is formed by a load-bearing frame, upon which the whole structure of the appliance is located. A rotating plate (A7) allows the correct positioning of the specimen basing on the position of the probe (A6) and the selected program and nature of test to be carried out. The appliance is programmed through the Control Panel (A1), which is located on the upper part of the appliance. The probe (A6) is operated by a step-by-step motor linked to an asymmetrical cam device, which drops into the specimen from a known height. The specimen – holder plate which is also powered by two step by-step motors, guarantees highly precise and repetitive positioning.

A1	DISPLAY
A2	PENETRATION NEEDLE
A3	GLASS PLATE
A4	CARBONFIBER FRAME
A6	PROBE
A7	SPECIMEN – HOLDER PLATE
A8	MAIN SWITCH + FUSE CARRIER

Specifications:

Internal encoder with 0,1 mm resolution

Minimum time between penetrations
time: 15 seconds

Power supply: 230V 1Ph 50-60Hz 50W

Dimensions: 240x360x440 mm Weight: 13
kg approx.



- Correctly train and educate the “QUALIFIED PERSONNEL” before allowing them access to the machine. The personnel must also be exhaustively trained with regards to the machine’s protection devices.
- Ensure the machine’s safety devices are not tampered with or removed and are checked daily. Provide the operator appropriate individual protection devices according to the laws in force.
- The constructor is available for clarification, assistance and training and declines all responsibility for damage to things or people resulting from improper, incorrect, and negligent use by untrained personnel.

1.12 STORAGE

	WARNING	The appliance must be stored and conserved in the original packaging and in a closed environment, protected from atmospheric agents with a minimum temperature of 5C°, and a maximum of +40C° and a maximum humidity of 70%.
---	----------------	--

1.13 TRANSPORTATION AND MOVEMENT

	WARNING	To avoid irreparable machine damage, move with care, do not overturn, protect from rain, do not stack, protect the packaging and its contents from bumps and sources of heat.
---	----------------	---

During transportation and movement, it is important to avoid bumps, overloading with other packages, exposure to freezing or heating atmospheric agents, or any other potentially harmful condition to the device, things or people.

1.14 PACKAGING REMOVAL

After removing the packaging check the machine is complete and that there are no visibly damaged parts. **DO NOT USE THE MACHINE** and refer to the constructor when in doubt.

	DANGER	The components used for packaging (plastic bags, polystyrene, nails, screws, wood, etc) must be kept out of reach of children, as they are sources of danger. These components should be placed in the appropriate containers.
---	---------------	--

	WARNING	In order to avoid bumps and overturn adopt the normal and logical precautions. Before disposing of the packaging check all machine components such as accessories, utensils, instructions, documents etc have been removed.
---	----------------	---

2. TECHNICAL CHARACTERISTICS

2.1 GENERAL MACHINE DESCRIPTION

The Vicatronic is formed by a load-bearing frame, upon which the whole structure of the appliance is located. A rotating plate (A7) allows the correct positioning of the specimen basing on the position of the probe (A6) and the selected program and nature of test to be carried out. The appliance is programmed through the Control Panel (A1), which is located on the upper part of the appliance. The probe (A6) is operated by a step-by-step motor linked to an asymmetrical cam device, which drops into the specimen from a known height. The specimen – holder plate which is also powered by two step by-step motors, guarantees highly precise and repetitive positioning.

A1	DISPLAY
A2	PENETRATION NEEDLE
A3	GLASS PLATE
A4	CARBONFIBER FRAME
A6	PROBE
A7	SPECIMEN – HOLDER PLATE
A8	MAIN SWITCH + FUSE CARRIER

Specifications:

Internal encoder with 0,1 mm resolution

Minimum time between penetrations
time: 15 seconds

Power supply: 230V 1Ph 50-60Hz 50W

Dimensions: 240x360x440 mm Weight: 13 kg approx.



- E042-02N** CONSISTENCY PLUNGER Ø 10x50 mm
- E042N** NEEDLE for final setting Ø 1.13 mm, BS, EN 196-3
- E042-01N** NEEDLE for final setting ASTM 1 mm diameter.
- E044-45** ADDITIONAL 700 g WEIGHT (EN, NF)
- E055-04** PLASTIC MOULD Ø 80/90x40 mm high following UNI
- E055-11** BRASS MOULD Ø 80/90x40 mm high following BS
- E055-13** PLASTIC MOULD Ø 65/75x40 mm high following DIN

SPARES

- E046N** Ø 1.13 mm hardened needle (EN 196-3)
- E046-01N** Ø 1 mm hardened needle (ASTM)
- E055-05** Plastic mould Ø 60/70 x 40 mm high following ASTM
- E055-07** Glass base plate
- E055-10** Plastic mould Ø 70/80 x 40 mm. high following EN, NF
- E042-06N** Probe 300 g to EN 196-3
- E044-48N** Tang to fix the needle to the probe
- C127-11** Thermo-paper roll for printer (pack of 10 rolls)

GYPSUM TEST

STANDARDS: EN 13279-2 | DIN 1168

E044-40 N

CONICAL PENETRATION NEEDLE, having 8 mm of diameter and 50 mm long, to make gypsum tests following EN, DIN Specifications.

E044-41 N

PROBE 100 g, to make test on gypsum following EN, DIN Specifications.



E044-40N

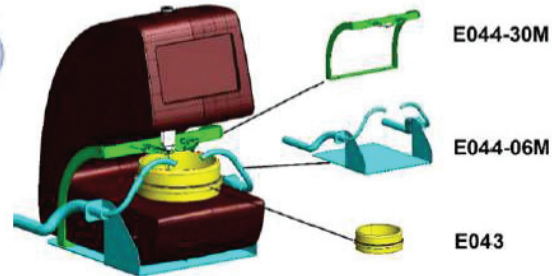

2.2 DIMENSIONS AND WEIGHT

Width (mm)	Depth (mm)	Height (mm)	Weight (kg)
233	356	461	13

Power supply: 230 V 1ph 50/60 Hz 50 W

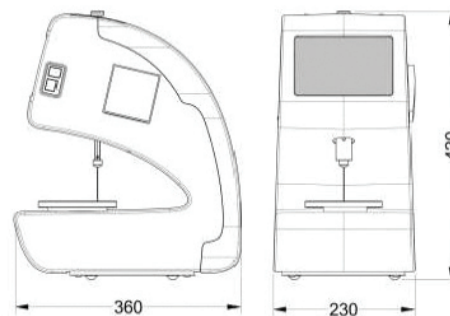

2.3 POWER SUPPLY

The identification plate is located on the rear side of the instrument, near the power cable outlet.

2.4 NOISE

The air noise emission levels shown do not necessarily imply the levels of exposure to the worker. The levels of exposure to the operator are obviously linked to the emission levels of the appliance; however other factors influence the levels of exposure to the operator: length of exposure, environmental characteristics, the presence of other machines etc. The appliance emission levels allow anyway an estimate to be carried out on the dangers due to noise.

	DANGER
Continuous use of the appliance and machines predictably present in the installation environment could cause a heightened daily personal exposure to noise.	

If the daily personal exposure is equal to or greater than 85 dB (A), it is advisable to use Personal Protective Equipment (Protective cap, Protective caps, etc.). If the daily personal exposure is equal to or greater than 90 dB (A), it is mandatory to use Personal Protective Equipment (Protective cap, Protective caps, etc.). For more information, consult the regulations in force in the country of installation.

3. GENERAL SAFETY STANDARDS

3.1 GENERAL STANDARDS

To ensure the safety of machine operators:

- Any tampering with the appliance not pre-emptively authorised by the manufacturer exempts the manufacturer from any responsibility for damage caused by or to it.
- The removal or tampering with safety devices entails a violation of the safety standards.
- Machine use is only allowed in areas where there is no risk of explosions or fires.
- Only the original fittings can be used. The use of unoriginal fittings exonerates the manufacturer from all responsibility.
- Check the appliance is in ideal working conditions and that its parts are not worn or faulty before Carry out all necessary maintenance
- Do not wear loose clothing, ties, chains, or anything else which could become caught in the frame or other moving parts of the appliance.
- Do not subject the appliance to violent impact.
- Do not expose the appliance to fire, welding sparks or extreme temperatures.
- Do not bring the appliance into contact with corrosive substances.
- Do not wash the appliance with jets of water.
- Check the workspace around the machine is clear from potentially dangerous objects.
- The machine operator must wear appropriate work clothing such as protective glasses, gloves, and mask to avoid damage from, for example, harmful dust projection. Wear a lower back support when lifting heavy parts. There should be no hanging objects such as bracelets or otherwise, long hair should be protected with relevant precautions, shoes must be appropriate for the type of operation to be carried out.

DURING USE

When operating check there are no conditions of danger. Immediately stop the machine when it is functioning irregularly. Contact the authorized Sales Service department.

For the operator's safety do not touch any part of the appliance when testing and use the appropriate individual protection devices to keep the operator safe.

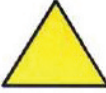
RISK OR DANGER		PROTECTION DEVICES	
FINGER SQUEEZE CUTS OR ABRASIONS		REINFORCED GLOVES	
MATERIAL FALL		ACCIDENT-PREVENTION SHOES	

3.2 MACHINE SAFETY DEVICES AND PROTECTION

DEFINITION: Protections are all the safety measures that consist of the use of specific technical means (repairs, safety devices) to protect people from dangers which cannot be limited reasonably in design.

	DANGER
<p>Tampering with the protections or any appliance modification could cause risks to users or other exposed people. The manufacturer does not assume any responsibility for direct or in direct damage to people, things or animals following tampering with the protections.</p>	

3.3 ACTIVE SAFETY DEVICES

Active Safety Devices are all those disposals and devices, which eliminate or greatly reduce the risks for the operator. They require a conscious and active behaviour of the operator to be activated.

On the rear panel a main switch can be found (A8) which also acts as an emergency switch

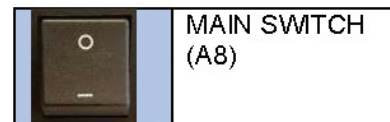

3.4 DANGEROUS PARTS AND RESIDUAL RISK

The dangerous zone is the space inside and around the machine where the operator could be wounded or injured. During the performance of some procedures the operator could face some risk of danger.

The risks can be eliminated following carefully the procedures written in this manual and using suitable safety devices.

4. INSTALLATION INSTRUCTIONS

4.1 LOCATION

The equipment must be placed in an ideal position and environment for the use it has been conceived for (laboratory use and protected from atmospheric agents) and that the machine is placed by a qualified operator.

ALLOWED TEMPERATURE

From +5°C to +40°C

ALLOWED RELATIVE HUMIDITY

from 30% to 70%

GENERAL ADVICE:

The machine must be installed in an area which allows ease of access to all parts so that maintenance may be carried out. Unauthorized people and objects which could be potential sources of danger must not be permitted in the area surrounding the machine. Do not position the equipment near instruments or appliances which could produce vibrations.

4.2 ASSEMBLING PROCEDURE

After removing the packaging, make sure the machine is intact, checking that there are no visibly damaged parts. In case of doubt DO NOT USE THE MACHINE and contact the retailer.

4.3 ELECTRICAL CONNECTIONS



Wiring of the electrical system must be carried out by qualified personnel.

Before wiring consult the electric plan linked to the instructions manual and the registration plate on the machine for information regarding supply, frequency and nominal current. Connect the earthing system via the PE terminal (yellow-green) before any other connection.

Apply a knife switch at the top of the connecting cable of the machine to the power system.

The knife switch must be combined with a safety device against the overload with a differential switch (safety switch). The technical features of the safety device must be in accordance with the standards in force in the country where the machine has been installed.

ELECTRIC TOLERANCES:

- Real voltage $\pm 10\%$ of the nominal one
- Frequency: $\pm 1\%$ of the nominal one in a continuous way
- $\pm 2\%$ of the nominal one for a short period
- The harmonic distortion of the sum from the second to the fifth harmonics not more than 10% of the total voltage as a real value between the conductors. A further distortion of 2% is accepted for the sum from the sixth to the thirtieth harmonics of the real total value between the conductors.
- With reference to the voltage imbalance of the three-phase voltage, the inverted sequence component and the zero-sequence component must not be more than 2% of the direct sequence component of the voltage.
- the zero-sequence component must not be more than 2% of the direct sequence component of the voltage.
- The voltage pulses must not last more than 1,5 ms with an up/down time between 500 ms and 500 ms and a peak value not higher than 200% of the real value of the nominal tension.
- The electric supply must not be interrupted or zeroed for more than 3 ms at any time. Between two interruptions it must not take more than 1 s.
- The interruptions must not overcome 20% of the tension peak for more than one cycle. Between two interruptions it must not take more than 1 s

The manufacturer assumes no liability for any damages to people, things and animals caused by the non-compliance of the above instructions.

5. MAN-COMMAND INTERFACE

5.1 WORKPLACE

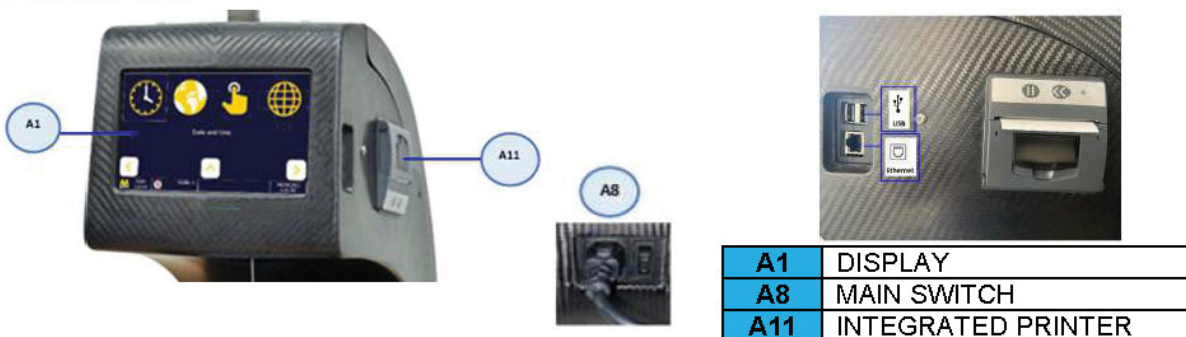

The operator carries out the normal functions of preparing the machine, equipping, and programming the test, moving in front of the machine. During the execution of the test, the operator monitors the operating status of the machine via the display on the panel.

TOUCH-SCREEN CALIBRATION

Beside it is shown the view for the touch screen calibration.



WARNING

Once the calibration procedure is activated it cannot be interrupted and must be completed.

How to calibrate the touchscreen

1. Keep Touched the pen at the middle of the scope, wait for the acquisition of coordinates, and then for the offset of the scope to the following position.
2. Repeat point 1 for the 5 proposed positions (in the middle, right below, up on the right, up on the left, down on the left).
3. Confirm the calibration touching the LCD display

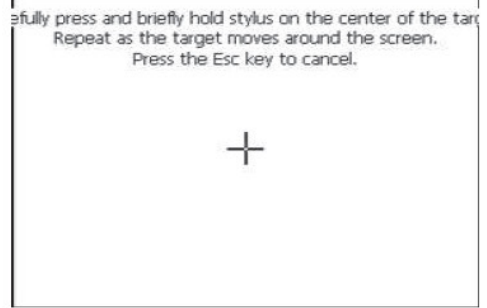

WARNING

In order to obtain a correct calibration, during the 5 steps requested by the procedure, its necessary to maintain the pen still as much as possible.

NETWORK CONNECTION

The screen network connections show the parameters for TCP/IP configuration, set up by the user (if DHCP is disable) or assigned by DHCP (if enabled).

Parameters	Values
DHCP	Select "Enable" to activate the configuration of a dynamic IP address (assigned by DHCP). Select "Disable" to activate the configuration of a static IP address (set up by the user).
IP address	This parameter is accessible only in case of disabled DHCP. In this case, set a valid IP address.
Subnet mask	This parameter is accessible only in case of disabled DHCP. In this case, set a valid subnet mask.
Gateway address	This parameter is accessible only in case of disabled DHCP. In this case, set the IP address of the gateway. This parameter is unnecessary if the machine is connected to a local network.
Server address for synchronized tick:	Used for connection to the server that manage the net synchronization of multiple devices. Set a valid IP, if requested.

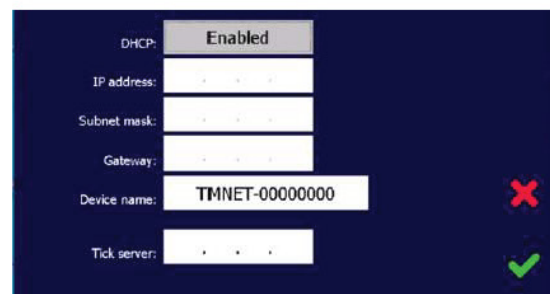

Net configuration (Parameters' alteration can be activated by pressing the button)



Closing of the view



Abort



Confirm



WARNING

For a proper configuration of the network, turn to the network's administrator or consult the provided helpsheet.

How to update the software

1. Select "Software update".
2. Select memory device.
3. Ensure that the memory device is in the proper slot and that the slot contains all files for the update in the roots.
4. Activate the execution button for update operation. 
5. Confirm the updating process and wait until it is finished. During the updating operation the device will be reactivated twice.

How to execute the backup of the configuration system

1. Select "Backup"
2. Select the memory device
3. Ensure that the memory device is in the proper slot
4. Activate the execution button for update operation 
5. Confirm the updating process and wait until it has finished.
6. Ensure that the folder "<dispositive name>" on the memory device has saved the "License.dat" file and that subfolders "Certificate", "Configuration", "Specimen" and "Standard", containing configuration files, have been created.

How to reboot the device with a temporary license (this function is used by technical assistance service for diagnosis system).

1. Select "Temporary license".
2. Select the device.
3. Activate the execution button for update operation 

How to the license

1. Select "License update".
2. Select the memory device.
3. Ensure that the memory device is located in the proper slot and that the slot contains "License.dat" file in the f
4. Ensure that the memory device is located in the proper slot and that the slot contains "License.dat" file in the fold 
5. Confirm the updating process and wait until it is finished. Then, wait for the device to be reactivated.

How to restore the configuration system

1. Select "Restore".
2. Select memory device.
3. Ensure that the folder "<dispositive name>" on the memory device has saved the "License.dat" file and that subfolders "Certificate", "Configuration", "Specimen" and "Standard", containing configuration files, have been created.
4. Activate the execution button for update operation 
5. Confirm restore and wait the end of the operation and the subsequent reboot of the electronics.

4. Ensure that the memory device is in the proper slot and that the slot contains "License.tmp" file in the fold.
5. Confirm the use of temporary license and wait for reboot.

Hot to exit to Windows

1. Activate the button to exit to Windows ().

2. Confirm the exit to Windows and wait the reboot



SYSTEM CONFIGURATION

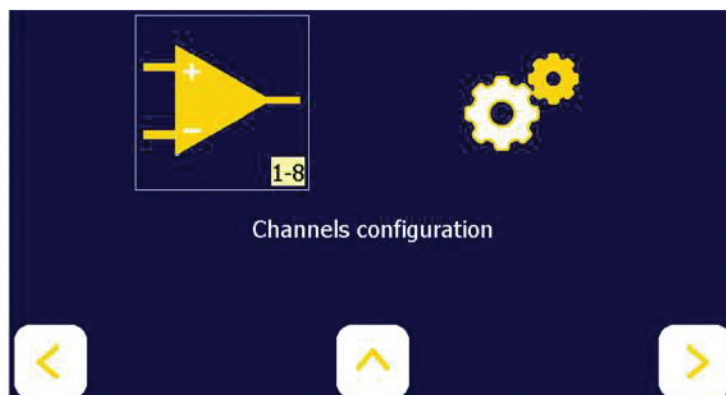

Analogue channel configuration
(**PROTECTED BY PASSWORD** –
default 3333)



Machine configuration (**PROTECTED
BY PASSWORD** – default 2222)

POWER SAVE SETTINGS

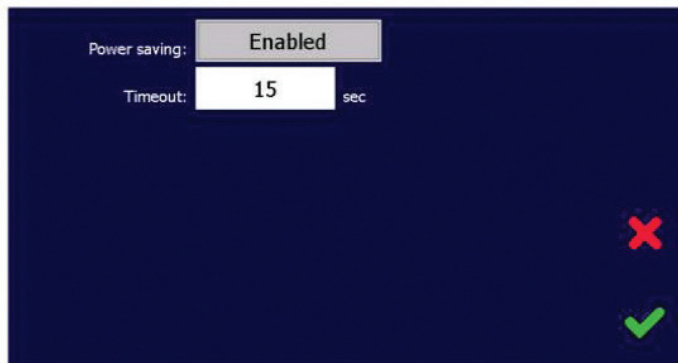

Power saving allows to automatically turn off the backlight of the display if no operator activity. Useful with battery tools because they increase the duration of the charge.

Parametes	Value
Power saving	"Enabled", "Disabled".
Timeout	Enter the time (seconds) after which, if no operator activity, the system turns off the backlight of the display to reduce power consumption. To reactivate the backlight "touch" screen, move the mouse or press any key.

Commands

- It cancels the changes
- It confirms the changes

PASSWORD

The password screen allows the personalization of access keys to "critic" function of the machine.

Parameters	Values
Profile password	Digit a numeric value
Device password	Digit a numeric value
Channel password	Digit a numeric value
Access password	Digit a numeric value
Software password	Digit a numeric value

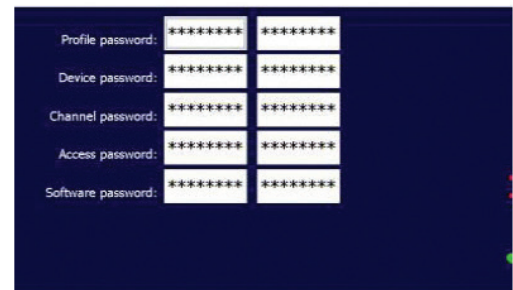

WARNING Every password it has to be digitated twice in order to avoid errors that may disable the current function.

Commands

- Abort
- Confirm

SOFTWARE MAINTENANCE

Device name (TMNET-xxxxxxx)
CPU name
Operating system
Operation
Memory support

Commands

- Exit to Windows
- Execution of selected operation
- Close screen

WARNING During the updating process (it may require few minutes) ensure that power supply of the components is kept active. Backup and restore of license and configurator will be executed automatically during the process.

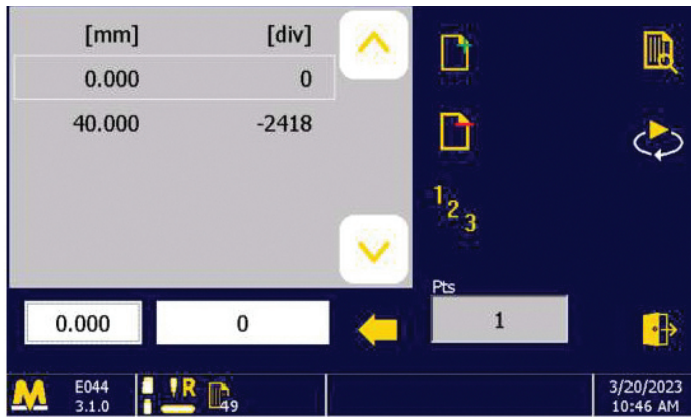

↑ Channel value for the selected step
 ↑ Channel points for the selected step
 ↑ Copy of points value calibration step

commands



- to start the calibration check screen
- to start the manual activation of the motor (only for load channels).
- to add / remove a calibration step
- to add equidistant values of steps over the full scale
- close the screen

To calibrate the analogue channels, proceed as follows:

1. Add to the calibration chart the number of the desired steps by using the key
2. Set manually the engineering values for the expected steps in the chart or initialize them with the default values (calculated in function of the number of the expected steps and of the full scale so as to have equidistant values) by using key . define manually the points corresponding to the engineering values, either manually acquire them using or start the manual activation by using

! WARNING The manual activation must be used only by qualified personnel, because it can cause the damage of the machine.

The calibration screen changes as follows:

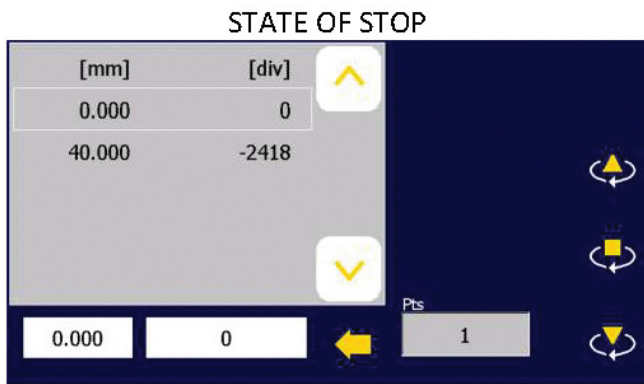

↑ Channel value of the selected step
 ↑ Channel points of the selected step
 ↑ Copy point value in calibration step

commands



- to move the probe upwards
- to stop of the activation
- to move the probe downwards

CALIBRATION CHECK

It is also possible to check the correct calibration of the channel, by using the button

Allows the selection of functions for “particular” configuration of the machine. The settings menu is the following:

NAVIGATION
COMMANDS



TO SCROLL THE COMMANDS



TO RETURN
TO THE TOP MENU

CONFIGURATION AND CALIBRATION OF CHANNELS



Use the key to access the channels configuration menu.

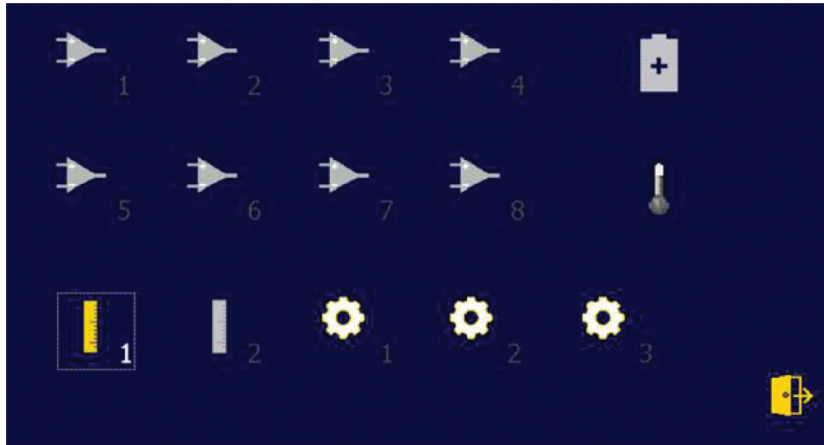

Configuration and calibration of an analogue channel can be chosen from the screen (ONLY CHANNEL 1 IS ACTIVE)

Selecting analogue channel 1, you access to the configuration screen, through which functions and data readout modalities can be determined.

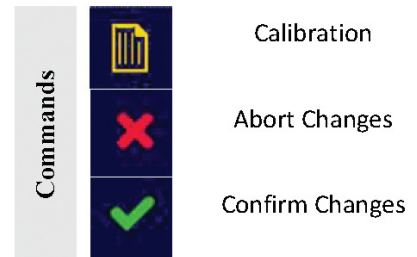
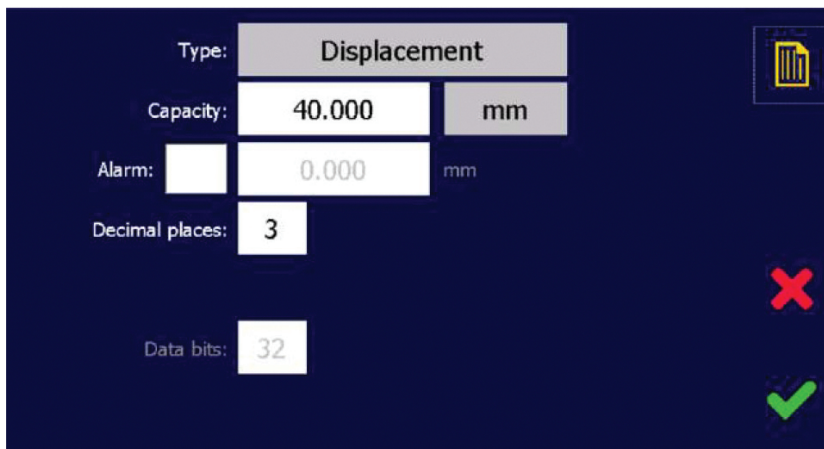

Parameter	Value
Type	Shows the information read by the analogue channel (Load, deformation, etc).
Capacity	Shows transducer full-scale connected to the analogue channel. The measurement system by which it is configured is independent and different from the measurement system indicated in the section “International settings”. The operator can digit the transducer’s capacity directly.
Alarm	If enabled, shows threshold beyond which an alarm is automatically generated on the analogue channel.
Decimal places	Decimal figures used to indicate the measure of transducer’s value.
Data bits	Shows the number of bits by which data are elaborated. By increasing the bits, increases resolution of the analogue channel and instability of the measurement.

CALIBRATION



Use the key to enter the calibration_screen

REV.	DESCRIPTION	MANAGED	APPROVED	PRODUCT CODE	PAGES	ISSUE DATE
01	Instruction Manual	EK	UTEC	E044M.M01.EN	16/31	03/2023

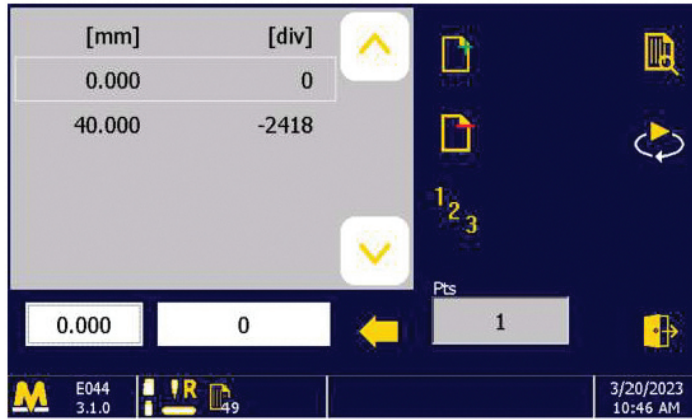

↑ Channel value for the selected step
 ↑ Channel points for the selected step
 ↑ Copy of points value calibration step



to start the calibration check screen
 to start the manual activation of the motor (only for load channels).
 to add / remove a calibration step
 to add equidistant values of steps over the full scale
 close the screen

To calibrate the analogue channels, proceed as follows:

1. Add to the calibration chart the number of the desired steps by using the key
2. Set manually the engineering values for the expected steps in the chart or initialize them with the default values (calculated in function of the number of the expected steps and of the full scale so as to have equidistant values) by using key . define manually the points corresponding to the engineering values, either manually acquire them using or start the manual activation by using

! WARNING The manual activation must be used only by qualified personnel, because it can cause the damage of the machine.

The calibration screen changes as follows:

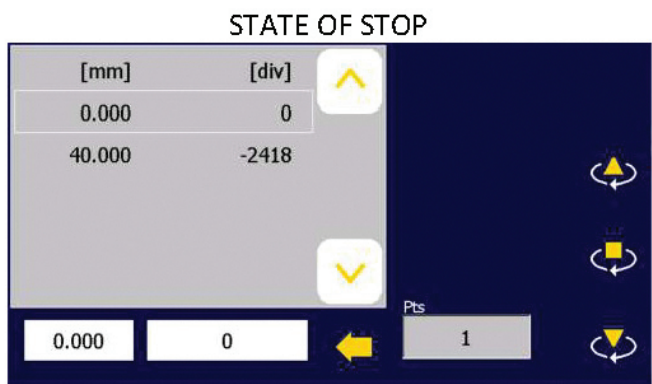

↑ Channel value of the selected step
 ↑ Channel points of the selected step
 ↑ Copy point value in calibration step

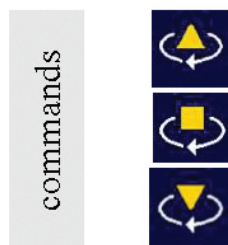

to move the probe upwards
 to stop of the activation
 to move the probe downwards

CALIBRATION CHECK



It is also possible to check the correct calibration of the channel, by using the button



to reset the analogue channel value
to start the manual activation of the motor (only for load channels)
Screen closure



Start the manual activation by pressing the button

	WARNING	The manual operation must be exclusively used by expert personnel because might cause machine damage.
--	----------------	---

The screen of calibration check changes as follows:

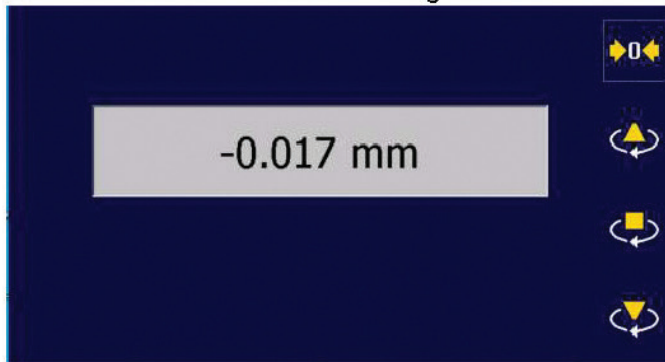

Readout zeroing
Increase/decrease the activation speed
Stop of the activation

CONFIGURATION OF THE MACHINE

Use the key to access the advanced configurations



Commands



Next page
Cancel changes
Confirm changes

Probe high speed:	1250	rpm	
Probe low speed:	1250	rpm	
Probe test speed:	1250	rpm	
Probe home position timeout:	10.0	sec	
Probe position timeout:	10.0	sec	

Parameter	Value	Unit of measure (metric)	Unit of measure (U.S.)
Probe high speed	➤ this speed is used to move the probe in phases during which a fast movement is allowed (typically when it goes up or when it has to enter the mold, even during the load regulation) [default value 1250 rpm]	rpm	rpm
Probe low speed	➤ this speed refers to the low speed of the probe [default value 1250 rpm]	rpm	rpm
Probe test speed	➤ this speed refers to the speed of the probe during testing	rpm	rpm

 WARNING	Insert the probe keeping it perfectly vertical and let it fall alone. An incorrect positioning or forcing could damage the internal mechanisms of the instrument.
 WARNING	Once the appliance is switched on do not touch, turn or move the specimen holder. If above instruction is not followed the appliance can be seriously damaged.

Before starting the calibration procedure, the screw that holds the needle must be loosened (see opposite picture) to prevent the needle from being damaged when it touches the glass plate.

In order to start the calibration procedure enter the instruments menu, position the glass plate (A3) and activate the “needle calibration” command.

The calibration procedure requires the memorization of two different points corresponding to the surface where the specimen is placed (glass plate) and to the upper surface of the specimen, equal to the height of the mould that will be used for the test, usually 40 mm

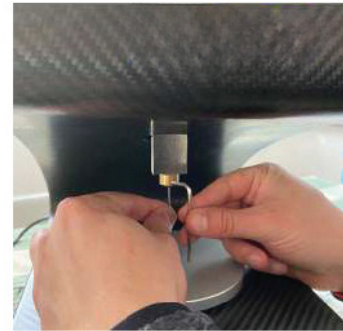

The calibration procedure consists of the following steps:

- The probe goes all the way down and the needle touches the glass plate (A3)
- The user must tighten the screw which was previously loosened (see above picture) in order to block the needle position corresponding to the 0 point of the calibration
- Once the screw is tightened, the user must confirm the first calibration step as per described in Par.
- The probe goes all the way up and the user must quickly place a 40 mm thickness between the needle and the glass plate (use of Johansson blocks is recommended). If such a thickness is not available, it is possible to use a different thickness, for example 30 mm, but this must be configured in the calibration procedure
- The probe goes down and the needle touches the blocks
- The user must confirm the second calibration step as per described in Par.
- The calibration procedure is done and the probe goes back to its initial position. The machine is now ready to start a test

7. IN FUNCTION - USE

7.1 MACHINE CALIBRATION – METERS - INDICATORS

The machine is checked in the factory, using sample equipment periodically checked by officially recognised institutes. These checks cannot guarantee that the machine, meters, and indicators will provide accurate values and results conforming to the standards in force in the countries the machine has been installed and used in. Normally such norms envisage calibration check after every movement. In order to obtain correct values and results it is therefore VITAL that the operator, once the machine has been installed and set up and before official tests, has an officially recognised body check the machine characteristics, its calibration and results/values reliability. The manufacturer is exempt from all responsibility in the case of direct and indirect damage from use of the machine without official approval by the relevant bodies.

7.2 SWITCHING ON



The feeding cable must be plugged into the electrical circuit.
Position the main switch on “I”.

When the machine is **switched on** it will be in the position ‘zero’ which verifies the position of the motors and puts them in the correct position for the test (positioning photo-sensor search). There will be a slight delay of between 8-10 seconds during positioning.

7.3 EQUIPPING



PROBE CLEANING DEVICE (OPTIONAL)

The probe-cleaning device is supplied assembled and ready for use with the Automatic Vicat Instructions must be closely followed to correctly mount the device on the appliance:

Parameter	Values
Plate position timeout	➤ The maximum time allowed for the plate to reach any other position different from home [default value: 30.0 sec]
Run log file	➤ This parameter allows the recording of the machine activation data for diagnostic purposes. Select "Off" to disable this function; select "Base" to create a log file with resumptive data about each single rotation. Select "Advanced" to create a log file with detailed data of each rotation.
Auto saving	➤ This option is for data autosaving. Select "Partial" to get a partial data file (without graphs). Select "Complete" to get a complete data file (with graphs).

ARCHIVE



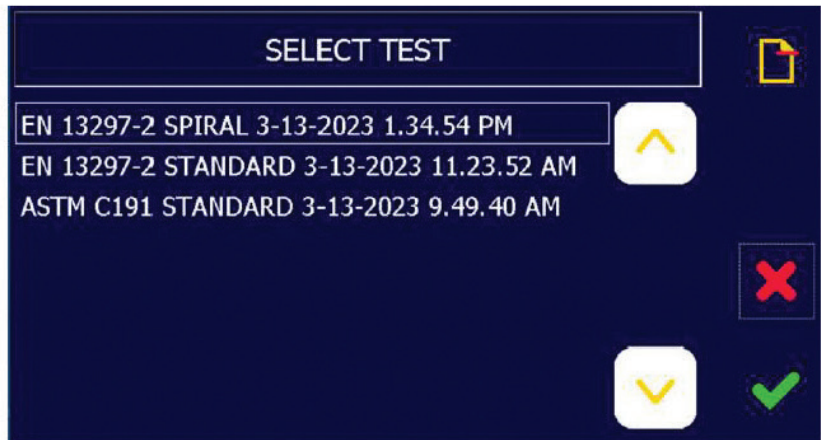

Use the key  to access the test archive

- Commands**
-  Delete test
 -  Cancel changes
 -  Confirm changes

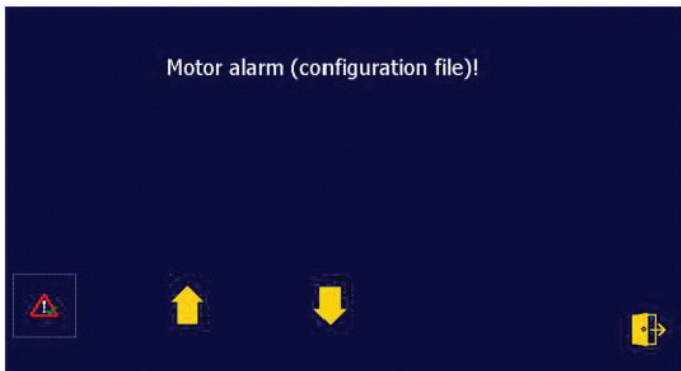

ALARMS



- Commands**
-  Alarm awareness/reset  Visualize previous alarm
 -  Close the screen  Visualize next alarm

How to confirm alarm awareness and execute alarm reset

1. Scroll the list of active alarms until the one of your interests is found.
2. Confirm the alarm awareness and reset it by pressing:

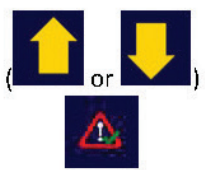





WARNING A reset alarm could appear again if the causes by which it has been plunged are not fixed.

6. MACHINE REGULATION AND TUNING

The first time these operations must be performed by qualified personnel in the presence of the operator in charge.

6.1 REGULATIONS

For safety reasons, the probe (A6) must be disassembled when transporting. Before use put it into the appropriate runners (from above).

 WARNING	Insert the probe keeping it perfectly vertical and let it fall alone. An incorrect positioning or forcing could damage the internal mechanisms of the instrument.
 WARNING	Once the appliance is switched on do not touch, turn or move the specimen holder. If above instruction is not followed the appliance can be seriously damaged.

Before starting the calibration procedure, the screw that holds the needle must be loosened (see opposite picture) to prevent the needle from being damaged when it touches the glass plate.

In order to start the calibration procedure enter the instruments menu, position the glass plate (A3) and activate the “needle calibration” command.

The calibration procedure requires the memorization of two different points corresponding to the surface where the specimen is placed (glass plate) and to the upper surface of the specimen, equal to the height of the mould that will be used for the test, usually 40 mm

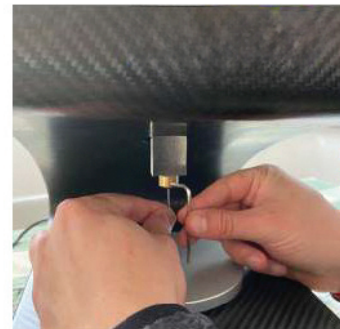

The calibration procedure consists of the following steps:

- The probe goes all the way down and the needle touches the glass plate (A3)
- The user must tighten the screw which was previously loosened (see above picture) in order to block the needle position corresponding to the 0 point of the calibration
- Once the screw is tightened, the user must confirm the first calibration step as per described in Par.
- The probe goes all the way up and the user must quickly place a 40 mm thickness between the needle and the glass plate (use of Johansson blocks is recommended). If such a thickness is not available, it is possible to use a different thickness, for example 30 mm, but this must be configured in the calibration procedure
- The probe goes down and the needle touches the blocks
- The user must confirm the second calibration step as per described in Par.
- The calibration procedure is done and the probe goes back to its initial position. The machine is now ready to start a test

7. IN FUNCTION - USE

7.1 MACHINE CALIBRATION – METERS - INDICATORS

The machine is checked in the factory, using sample equipment periodically checked by officially recognised institutes. These checks cannot guarantee that the machine, meters, and indicators will provide accurate values and results conforming to the standards in force in the countries the machine has been installed and used in. Normally such norms envisage calibration check after every movement. In order to obtain correct values and results it is therefore VITAL that the operator, once the machine has been installed and set up and before official tests, has an officially recognised body check the machine characteristics, its calibration and results/values reliability. The manufacturer is exempt from all responsibility in the case of direct and indirect damage from use of the machine without official approval by the relevant bodies.

7.2 SWITCHING ON



The feeding cable must be plugged into the electrical circuit.
Position the main switch on “I”.

When the machine is **switched on** it will be in the position ‘zero’ which verifies the position of the motors and puts them in the correct position for the test (positioning photo-sensor search). There will be a slight delay of between 8-10 seconds during positioning.

7.3 EQUIPPING

PROBE CLEANING DEVICE (OPTIONAL)

The probe-cleaning device is supplied assembled and ready for use with the Automatic Vicat Instructions must be closely followed to correctly mount the device on the appliance:

1. Position the cleaning device as shown in the picture. Ensure the device is correctly centred on the screw holes.
2. Regulate the device so the pads are perfectly aligned with the needle.
3. Tighten the fixing screws completely.

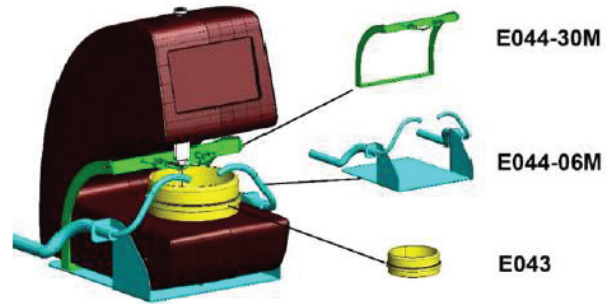

	WARNING
It is advisable to replace the pads before each test. See the following paragraph.	

PAD REPLACEMENT

For pad replacement, follow these instructions:

1. Push the fixing button pad holder in order to free and remove the holders easily.
2. Cut some new pads with a 65 mm length and insert them into the special holders.
3. Push the fixing button pad holder, replace the holders so they fit the needle perfectly, and then release the stroke.
4. Add three or four oil drops into the holders and wait at least a couple of minutes before starting a test

	WARNING	If a mould tank is being used for water testing of the specimen (OPTIONAL), assemble the supporters after the insertion of the mould tank and disassemble them before the insertion of the mould tank.
--	----------------	--

7.4 SAMPLE POSITIONING

	WARNING	Before using the appliance for routine procedures ensure that the installed probe is suitable for the test to be performed
--	----------------	--

The preparation as well as the positioning of the material to be tested can be done in different ways depending on the test nature. For correct specimen preparation and positioning, refer to the specific standards.

7.5 SWITCHING THE APPLIANCE ON

Press to start the test

7.6 NORMAL STOP

Press to stop the test

7.7 EMERGENCY STOP

To switch off the machine position the main switch on "0".

7.8 START UP AFTER EMERGENCY

		WARNING DANGER	It is recommended to find the causes that stop the test and set the initial conditions
--	--	---------------------------	--

7.9 START UP AFTER STOP COMMANDED BY SAFETY CIRCUIT

Close the window. Confirm the view of the alarm and reset it by release the button.

7.10 SWITCHING OFF

- stop the execution of the test if it is still ongoing

put the main switch on the "0" position and disconnect the power supply

7.11 TEST START UP

Before using the appliance regularly check it is working correctly by carrying out at least one complete empty cycle according to the previous instructions.

Should there be any problem consult the chapter "DIAGNOSTICS".

If the instructions in this manual do not provide the solution to the problem, contact Sales Assistance.



VICATRONIC TEST

1. Tap on the test icon  to enter the test configuration screen

Commands



Extended Configuration



To start the TEST



To close the screen

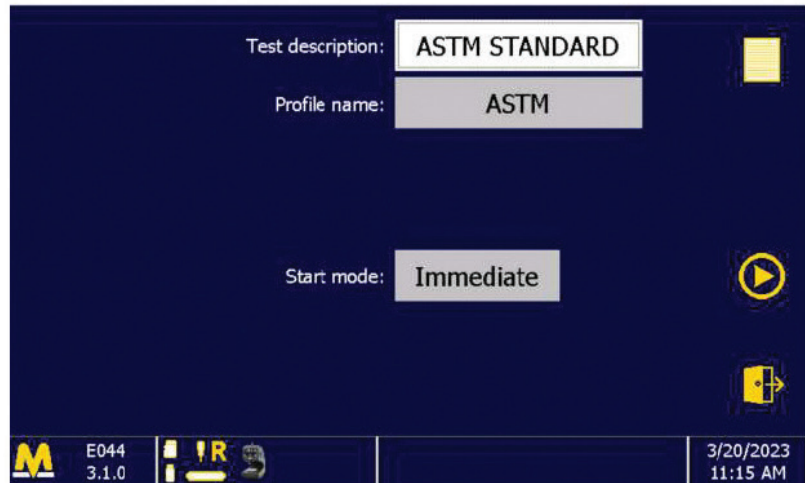

Parameters	Values	Unit of measure (metric)	Unit of measure (U.S.)
Test description	➤ Description that identifies the test. The test will be saved using this name and date /time information		
Profile name	➤ Select the test program among the ones proposed or from a custom one*		
Start mode	➤ Select the start test mode among IMMEDIATE, DELAYED or TIMED. IMMEDIATE means that the test will start as soon as the play button is pushed		

*The Vicatronic allows to select the following test programs:

STANDARD	DIAMETERS (mm)	PENETRATIONS (num.)	TOTAL
ASTM	20.50 – 14.10 – 7.70 – 0.00	20 + 13 + 7 + 1	41
BS4550	30.00 – 20.00 – 10.00 – 0.00	17 + 11 + 5 + 1	34
DIN1168 GYPSUM	30.00 – 16.50 – 0.00	14+ 7 + 1	22
EN	25.00 – 15.00 – 5.00	15 + 9 + 2	26
EN196-3:2005	26.00 – 20.75 – 15.50 – 10.25 – 5.00	15 + 12 + 9 + 6 + 1	43
EN 480-2	26.00 – 20.75 – 15.50 – 10.25 – 5.00	15 + 12 + 9 + 6 + 1	43
EN13279-2	30.00 – 16.50 – 0.00	14 + 7 + 1	22
90 DROP	30.00 – 24.00 – 18.00 – 12.00 – 6.00	31 + 25 + 18 + 12 + 4	90
SINGLE	0.00	1	1
SPIRAL	25.00 – 20.00 – 15.00 – 10.00 -5.00 – 0.00	24 + 18 + 12 + 6 + 3 + 1	64

Start mode: DELAYED

Commands



Extended Configuration



To start the TEST



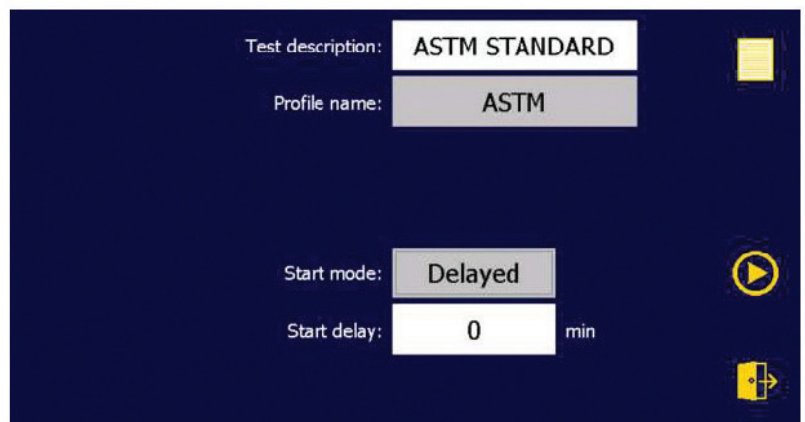

To close the screen



Parameters	Values	Unit of measure (metric)	Unit of measure (U.S.)
Start delay	➤ Set a time delay for the start of the test from 0 to 999 minutes.	min	min

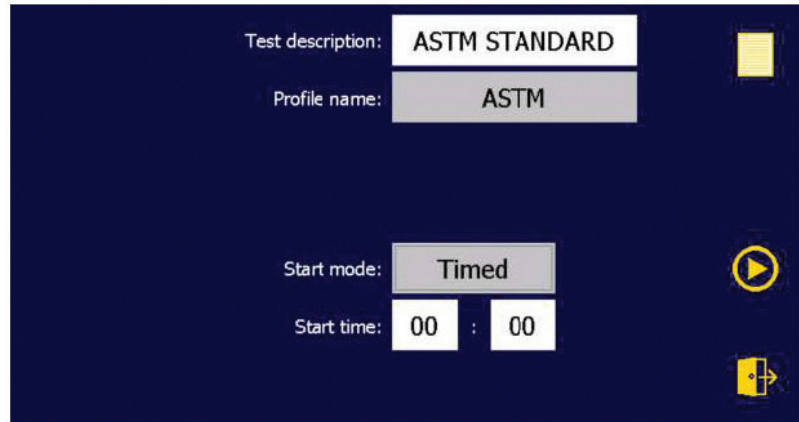

Start mode: TIMED

- Commands**
-  Extended Configuration
 -  To start the TEST
 -  To close the screen



Parameters	Values	Unit of measure (metric)	Unit of measure (U.S.)
Start time	➤ Set a time for the start of the test		

2. Tap the button  to switch to the screen showing the advanced test parameters

- Commands**
-  To enter the advanced parameters
 -  To enter the penetrations time window
 -  To close the screen

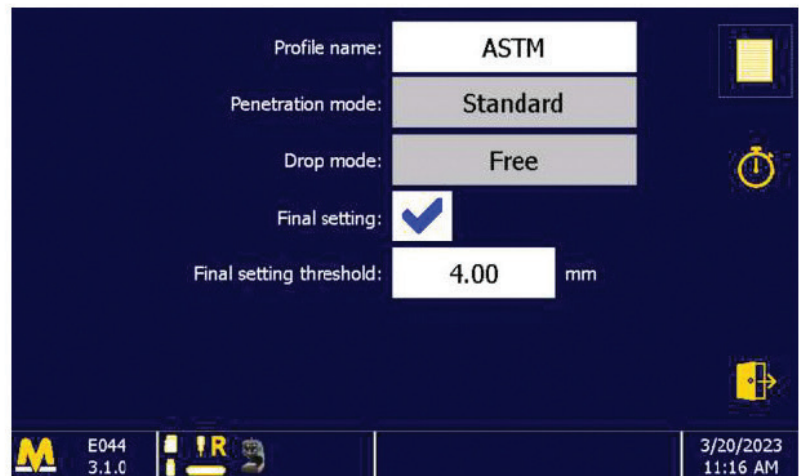

Parameters	Values	Unit of measure (metric)	Unit of measure (U.S.)
Profile name	➤ To change the profile name		
Penetration mode	➤ Select the penetration mode among STANDARD (single penetration per each point), DOUBLE (it means a double round of penetrations on each diameter; the penetrations of the second round are made halfway between those made during the first round) or SPIRAL (single penetrations per point along a spiral path)		
Drop mode	➤ Select the drop mode among DRIVEN (the probe will be lightly rested on the specimen) or FREE (the probe will fall on the specimen freely)		
Final setting	➤ To activate the final setting option		
Final setting threshold	➤ Set the threshold value of the final penetration	mm	inc

3. Tap the button  to switch to the screen showing the penetrations phases (position). Each phase includes the number of penetrations (num.) to be carried out on each diameter (mm).

Commands



- To add a new step
- To delete a step
- To close the screen

[mm]	[num.]
20.50	20
14.10	13
7.70	7
0.00	1

↑ ↑
Diameters Number

The screen above indicates four phases:

First phase: includes twenty penetration on the diameter 20.50 mm.

Second phase: includes thirteen penetrations on the diameter 14.10 mm

Third phase: includes seven penetrations on the diameter 7.70 mm

Fourth phase: includes one penetration on the centre of the mould.

4. Tap the button  to switch to the screen showing the penetrations time.

Commands



- To switch to the next screen
- To close the screen

Default penetration time: 0.25 min

Parameters	Values	Unit of measure (metric)	Unit of measure (U.S.)
Default penetration time	➤ Time from one penetration to another [Default value: 0.25 mm]	mm	inc

5. Tap the button  to switch to the screen showing the penetrations phases (time). Each phase ends with the penetration number set in ID column of the same phase and begins with the penetration number set in ID column of the previously phase (or the beginning if it concerns the first penetration)

Commands



- To switch to the next screen
- To return to the previous screen
- To close the screen

[ID]	[min]
10	3.00
25	2.00
41	1.00

↑ ↑
ID time

The screen above indicates three phases:



First phase: includes the penetrations from 1 to 10 with an interval of 3 minutes.

Second phase: includes the penetrations from 10 to 25 with an interval of 2 minutes.

Third phase: includes the penetrations from 25 to 41 with an interval of 1 minute.

6. Tap the button  to switch to the screen showing the penetration time for each diameter

Commands

-  To switch to the next screen
-  To return to the previous screen
-  To close the screen



The screen above indicates 2 phases:

First phase: includes the penetrations from 5 to 8 mm when the penetration interval is 3 minutes.

Second phase: includes the penetrations from 8 mm with an interval of 5 minutes.

	WARNING	The instrument will search for the first useful criteria among the ones set, if none of them can be used, the penetration time used will be the default one.
---	----------------	--

TEST EXECUTION

1. Make sure that the machine is in the ready state (highlighted by the icon  in the status bar)

2. Press the key  to execute the test.

	WARNING	After touching the icon  the probe will start moving downwards. If the calibration of the needle has not been positioned correctly, the probe will not be able to complete its travel and the machine will get an alarm.
---	----------------	---

3. Further to confirmation, the test execution screen appears

Time from the test start up	→	Time: 0:00:35
Time to go for the next penetration	→	Time to penetration: 0:00:15
Number of penetrations made	→	Penetrations: 2
Last penetration depth	→	Last penetration: 24.86 mm
Maximum penetration depth	→	Maximum penetration: 24.86 mm

↑
End test

4. Press, the button  at any time to finish the execution of the test.
5. At the end of the test, the screen with the results automatically appears:

RESULTS

At the end of the test, the screen with the test results will be displayed showing the reason why the test ended



to close the screen

to enter the screen for storage and printing

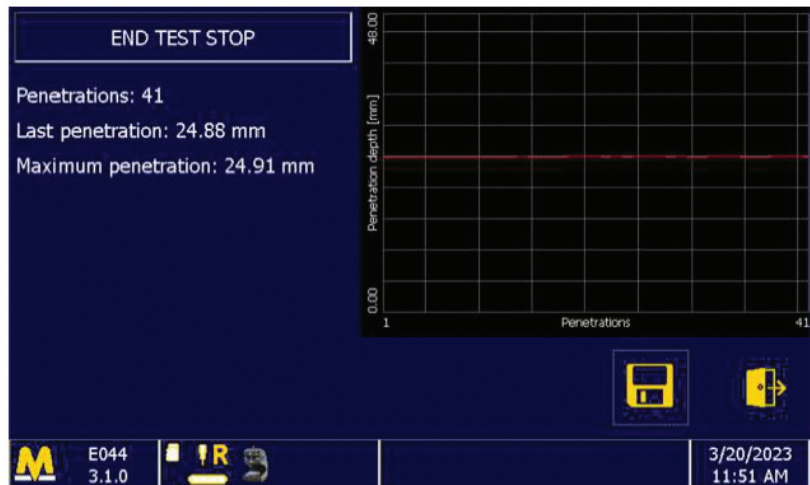



STORAGE AND PRINTING

Press the key  to activate the screen for storing and printing the test results.

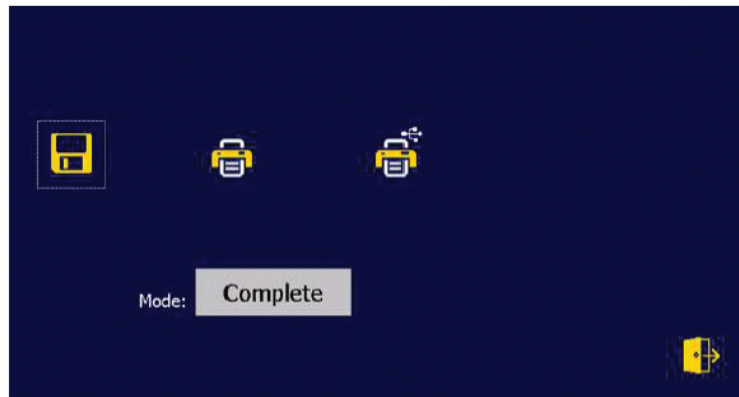
Select the print mode (partial - numerical data only, complete - numerical and graphic data). This mode has no effect in the case of printing on a USB printer (PCL compatible). Press the key to print on a thermal printer (if available)



Make sure there is a PCL compatible printer connected and press the button  to print to the USB printer.

Make sure there is a storage device (SD-Card, Pen-Drive) in its slot and press the button  to carry out the data storage. The data will be saved, in order of priority, on SD-Card or Pen-Drive. The created file will have a name built automatically by combining the description of the test (parameter that can be set in the first configuration screen) with the date and time of the test execution

Close the saving and printing screen using the button .

8. MAINTENANCE

8.1 ORDINARY MAINTENANCE

	WARNING DANGER	Periodically clean all machine parts and oil the unpainted parts in order to preserve the machine and its efficiency. Avoid the use of solvents which damage paint and parts in synthetic material.
---	---------------------------	--

8.2 EXTRAORDINARY MAINTENANCE

	DANGER	The removal of the safety devices or any tampering of the machine could cause risks to the operator or to any other people.
---	---------------	---

For extraordinary maintenance operations refer directly to the Manufacturer.

8.3 AUTHORIZED MAINTENANCE CENTRES

For information on the nearest authorised help centre it is essential to contact the manufacturer.

9. GUIDE TO RECOGNISING DAMAGE AND ANOMALIES

This chapter presents and discusses all the simple problems which could occur during machine use. The appropriately qualified, professional personnel must carry out all the maintenance procedures, check and control, as well as all the repair operations on parts of the machine or the electrical system.

Contact Technical Sales Assistance for any other problem not listed on the previous table or should the malfunctioning persist after the intervention of the operator in accordance with the previously mentioned courses of action.

HARDWARE SIDE

PROBLEM	POSSIBLE CAUSE	CURE
After acting on the Main Switch, the appliance doesn't switch on.	Lack of supply	Check the right use of the Main Switch Verify the Main in the Panel
	Fuses are broken	Replace the fuses with new fuses of the same capacity.
The probe (A6) doesn't go up or down completely.	Probe broken or damaged	Contact the After Sales Service for probe replacement
	Failure of the inside components of probe movement.	Contact the After Sales Service
The probe (A6) stops when going upwards or downwards.	Failure of the inside components of probe movement.	Contact the After Sales Service
The rotating plate does not turn or turns slowly	Failure of the inside mechanisms of the rotating plate	Contact the After Sales Service
The Control Panel buttons are out of order.	Control Panel failure	Contact the After Sales Service

SOFTWARE SIDE

PROBLEM	POSSIBLE CAUSE	CURE
SNAP communication alarm!	SNAP communication alarm!	Contact the Technical Assistance Service.
SNAP communication alarm (RXWRONGHDRCHK)!	SNAP communication alarm!	Contact the Technical Assistance Service.
SNAP communication alarm (RXWRONGLEN)!	SNAP communication alarm!	Contact the Technical Assistance Service.
SNAP communication alarm (RXWRONGEDM)!	SNAP communication alarm!	Contact the Technical Assistance Service.
SNAP communication alarm (RXWRONGDAB)!	SNAP communication alarm!	Contact the Technical Assistance Service.
SNAP communication alarm (RXWRONGSEQ)!	SNAP communication alarm!	Contact the Technical Assistance Service.
SNAP communication alarm (RXNAK)!	SNAP communication alarm!	Contact the Technical Assistance Service.
SNAP communication alarm (RXTIMEOUT)!	SNAP communication alarm!	Contact the Technical Assistance Service.
SNAP communication alarm (RXWRONGCOMMAND)!	SNAP communication alarm!	Contact the Technical Assistance Service.
SNAP communication alarm (ALLOCERROR)!	SNAP communication alarm!	Contact the Technical Assistance Service.

SNAP communication alarm (KEEPALIVE)!	SNAP communication alarm!	Contact the Technical Assistance Service.
System information unavailable!	System information unavailable!	Contact the Technical Assistance Service.
Motor 1 alarm!	Motor or motor control failure	1. check if motor control is powered on 2. check wires between motor and motor control 3. check wires between motor control and CORE board 4. Contact the Technical Assistance Service.
Short circuit outputs alarm!	Digital output failure	Contact the Technical Assistance Service.
Motor alarm (configuration file)!	Missing configuration file	1. restore original configuration of the machine 2. contact Matest
Motor N alarm (configuration file)!	Missing configuration file	1. restore original configuration of the machine 2. contact Matest
Run alarm (timeout)!	Axis failure	1. chek if the motor can freely run 2. check proximities 3. contact Matest

10. SPARE PARTS

	WARNING DANGER	<p>Only original spare parts can be used.</p> <p>Use of unoriginal spare parts exempts the manufacturer from all responsibility. Procedures for substitution of spare parts will be provided by the manufacturer along with the part. For spare parts contact the manufacturer's Sales Service department.</p>
--	---------------------------	--

11. INACTIVITY

Ensure all machine parts are in safe working order before operating it again should the machine be inactive for a long period of time. When in doubt contact the Manufacturer.

12. DECOMMISSIONING THE MACHINE

Should it be decided that the machine is to be no longer used, proceed as follows:

- Disconnect the electrical supply network by removing the connecting cable therefore making it unusable.
- Make the potential sources of danger harmless, such as sharp or protruding parts.
- Dismantle the machine; divide it into similar parts and dispose of according to the standards in force

Recycling notice for the disposal of electrical and electronic devices



This symbol, shown on the device or on the package and/or the documentation, suggests that the device should not be disposed together with other home garbage at the end of its life cycle. To avoid further environment, or health-care damage, caused by the unsuitable disposal of garbage, the user should separate this device from other different types of garbage and recycle it in responsibly to avoid the reuse of material resources. Users must take care at the disposal of the equipment by taking it to the nearest recycling site for appropriate recycling treatment for electrical and electronic devices. Gathering and Recycling deplete devices allow the preservation of natural resources and grant them the adequate treatment by respecting health and environment. For further information on your local recycling site please contact your local council or city waste treatment department.

13. ELECTRICAL DRAWINGS

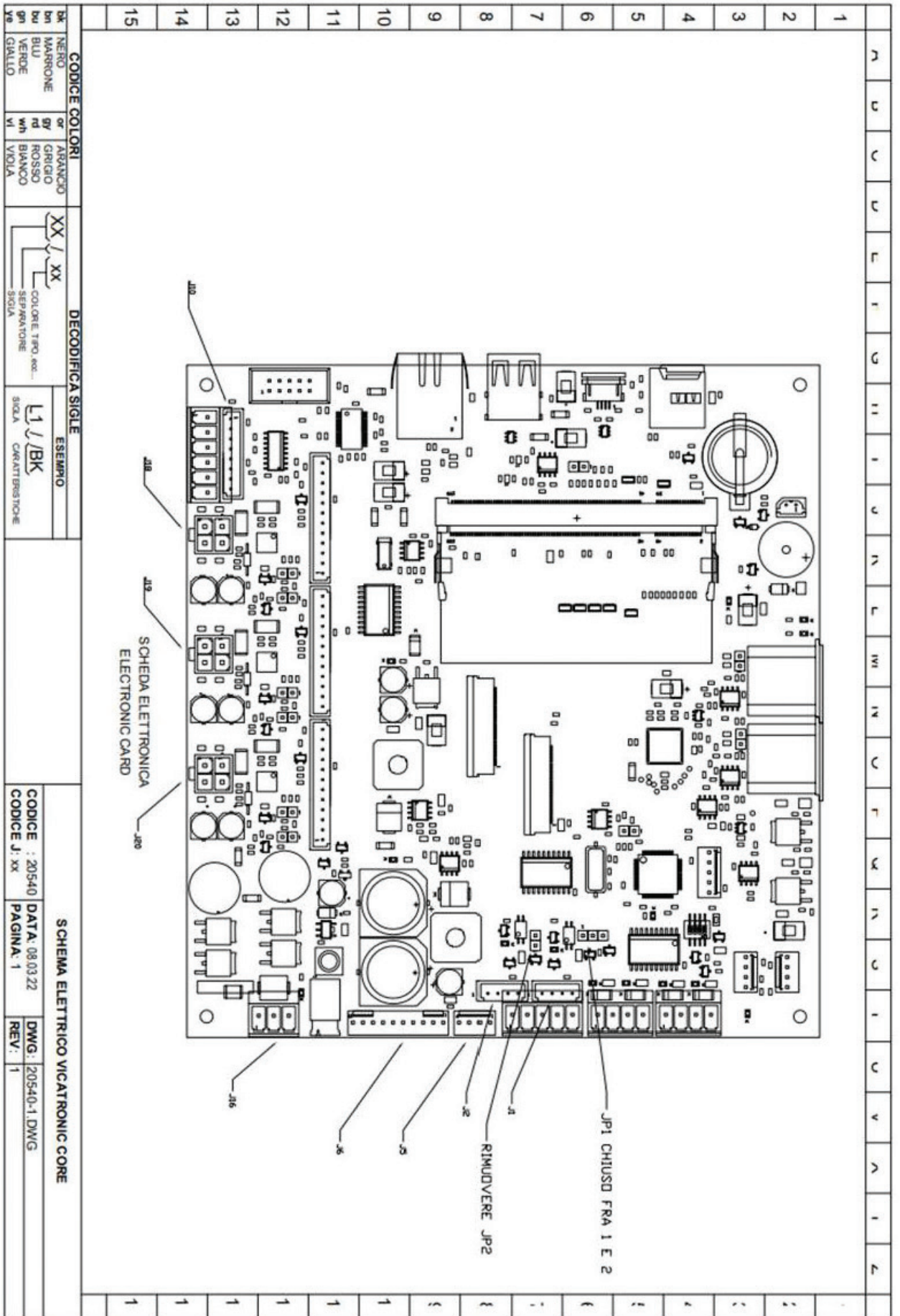

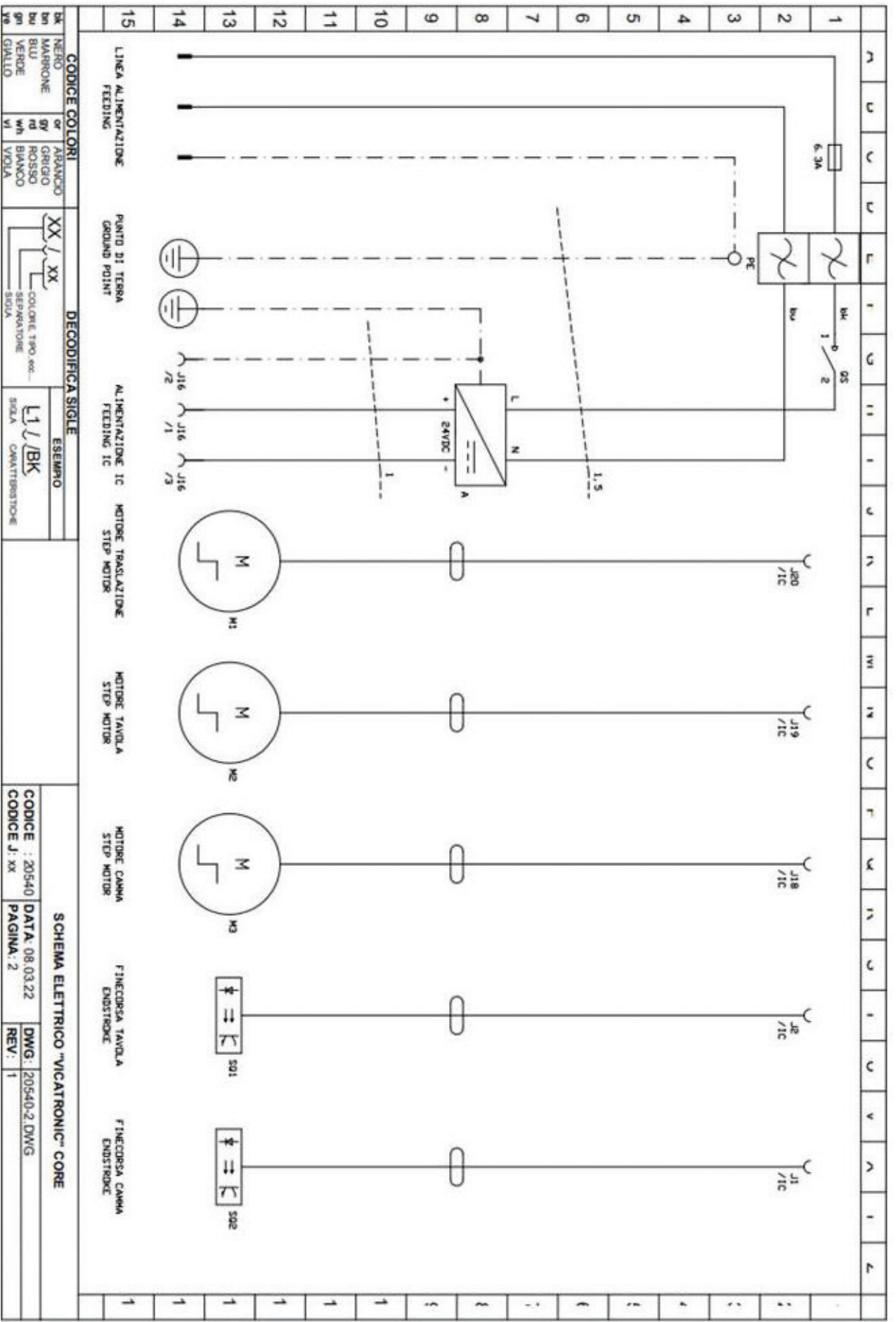

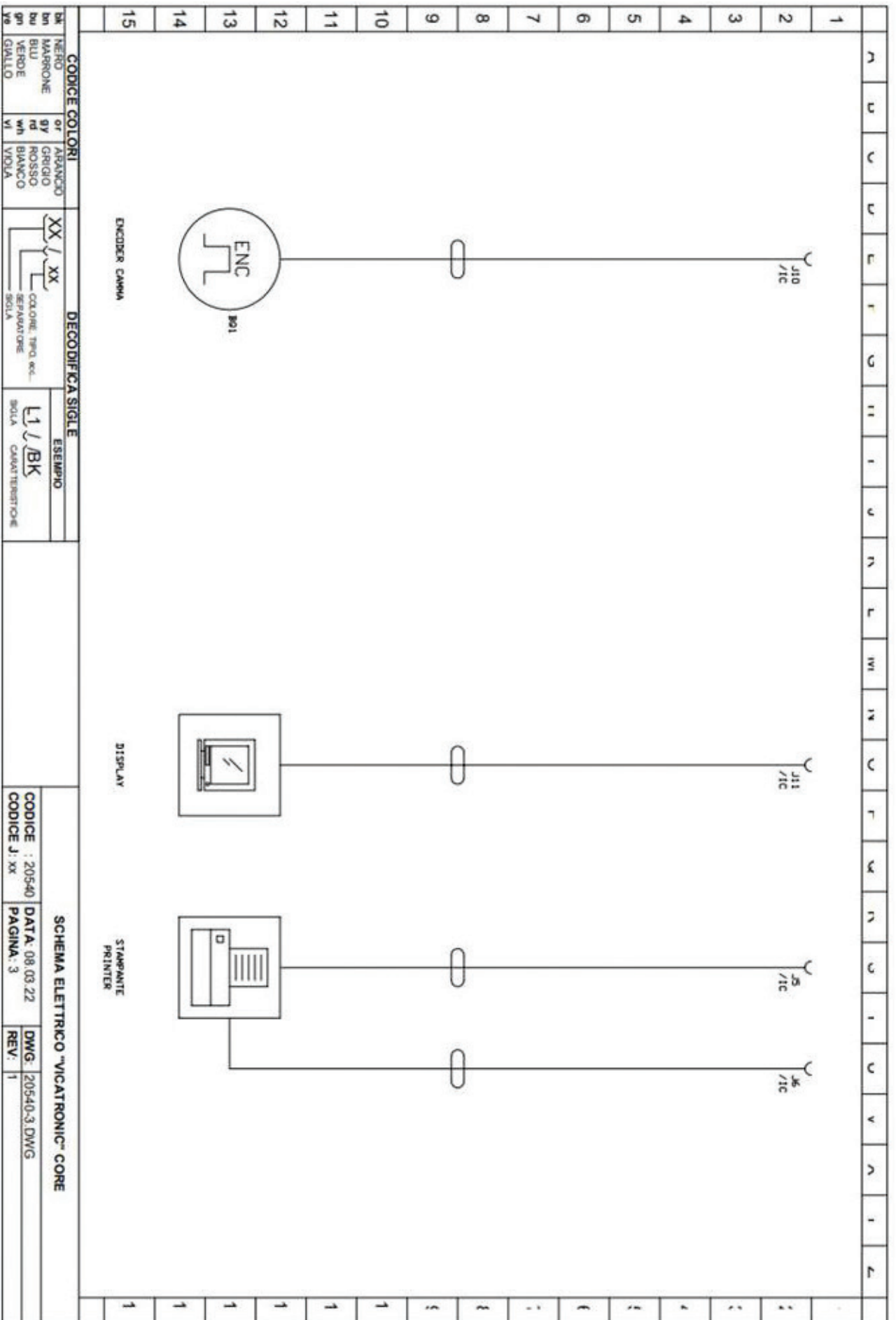

**Humboldt Mfg. Co.
875 Tollgate Road
Elgin, IL 60123**

**1.800.544.7220
hmc@humboldtmfg.com**

Testing Equipment for



Construction Materials

HUMBOLDT

www.humboldtmfg.com