



# H-3248 and H-3250



H-3250D



H-3250

## Length Comparators



## **Introduction:**

Length comparators measure length changes of hardened cement paste, mortar and concrete prismatic specimens. Indicators are mounted on a sturdy upright support attached to a solid triangular base. All units include an Invar reference bar and stationary and movable anvils designed to fit H-3260 gauge studs, which are cast into test specimens. Humboldt Length Comparators comply with ASTM C151, C157, C227, C311, C341, C342, C452, C490, C596; AASHTO M210, T107, T160. **Custom length comparators are also available, contact us for details.**

Length Comparators consist of three main components:

- A base with an upright frame, which includes an adjustable terminal and collar on the base.
- A dial or digital indicator with an adjustable terminal and collar.
- A reference bar for calibration. An Invar Test Bar is included for this purpose. A 10" effective-length bar is included with the H-3250 and a 16" effective-length bar is included with the H-3248.

**Note:** ASTM C806 and C878 require specimens to be measured while under restraint. For those using these specifications different collars are required for the Length Comparator. For ASTM C806 order H-3251 collars and for ASTM C878 order H-3257.5 collars.

Humboldt Length Comparators can also be used to measure length changes of prismatic specimens over an effective gauge length of 5". To accomplish this, it is necessary to use our 5" adapter, H-3250.8 and a 5" Reference Bar, H-3249.1.

## **Unpacking**

Your equipment was thoroughly inspected before it was shipped and should be ready to operate as soon as you have completed the set-up procedure. Notify Humboldt Mfg. Co. or your local agent and file a claim with any carriers involved if you find any damage to the machine. Unpack all of the equipment carefully to prevent loss of small items or manuals.

## **Assembly & Set-up**

Place the comparator frame on a stable surface with sufficient space to work. If using digital models, a receptacle to power the digital indicator may be desired. It is recommended the instrument be checked and adjusted when received using the Standard Invar Test Bar as follows (dial-type indicator example):

With the test bar in place between the terminals, set the large hand on the outer scale and the hand on the lower small scale (0.010" movement) on "0". The upper small scale (0.100" movement) should be set on "2". If adjustment is necessary, loosen the hex locking nut on the terminal elevating screw at the base and adjust the height of the terminal until the hand on the upper small scale (0.100" movement) is on "2". Hold base terminal in place and tighten lock nut.

## **Operation**

Use for measuring length changes of hardened cement paste, mortar and concrete prismatic specimens to 0.0001-inch accuracy.

Specimens are placed between the two terminals on the Length Comparator. These terminals are equipped with collars, and both are shaped to meet the measuring studs cast into the ends of the test bars. The upper terminal is attached to the end of the indicator spindle and is adjustable due to the functioning of the indicator. The lower terminal is stationary, being attached to the base with a threaded elevating screw through the base and held in place with a hex lock nut. The lower terminal needs to be adjusted to obtain a proper reading on the indicator. This is done using the Invar Test Bar (see Assembly and Set-up above).

In operating the Comparator, specimens should be placed into the instrument with the Indicator retracted. The specimen is set against the lower terminal and the indicator is released, very slowly and carefully, to allow contact of the upper terminal with the gage stud of the sample.

## **Operation of Mechanical Dial Indicator**

The outer scale around the circumference of the dial directly indicates in 0.0001" increments with a range of 0.4000". The scale may be rotated to set zero at any indication of the needle pointer then locked with the set screw. The two smaller scales with needle pointers on the face of the dial indicate the number of revolutions of the large pointer. One full revolution of the gauge's large hand on the outer scale is equal to .010"

One full revolution of the hand on the small, lower scale is equal to .100" Every full revolution of the hand on the small, lower scale is recorded on the upper small scale, up to the maximum of 4. Refer to Figure 1 for an explanation.

# Reading Instructions for H-3250.3 Dial Gauge



figure 1

The gauge shown above has a total range of .400". This is indicated by the upper small scale, which goes to 4. The gauge has an accuracy of .0001", which is measured on the large outer scale. Each gradation of the outer scale is equal to .0001"

One full revolution of the gauge's large hand on the outer scale is equal to .010"  
One full revolution of the hand on the small, lower scale is equal to .100"  
Every full revolution of the hand on the small, lower scale is recorded on the upper small scale, up to the maximum of 4.

Example:

Large hand is on 84,  
the small, lower scale's hand is between 4 and 5 on the scale,  
the small, upper scale's hand is between 2 and 3

**2484**

reading from the large outer scale  
reading from small lower scale  
reading from small upper scale

## Operation of Digital (Electrical) Indicator

This dual power indicator uses either internal batteries or an external AC Adapter for operating power. The standard lithium batteries are Manganese Dioxide Chemistry, listed under IEC # CR2450. A standard 2.5mm audio jack is provided for use by the 9 VDC AC adapter; center pin is "+" (positive).

### Installing batteries:

Using a narrow edge screwdriver, gently pry under the tab on the left side of the bezel and slide out the battery tray as you turn the indicator face side down. Insert two batteries, + side up, into tray cavities, then slide the tray back into its bezel slot, taking care that the batteries stay in proper position.



figure 2

## Basic Operating Instructions

Please refer to figure 2 for the instructions below:

### ON/OFF:

To turn Indicator On: Press ON/clr and release when clr appears.

To turn Indicator Off: Press and Release OFF

### CLEAR:

To Clear Display to zero: Press and Release On/clr

### HOLD:

To Turn Max. Hold On/Off: Press and Release HOLD

### INCH/MILLIMETER:

To change from inch to millimeter, or millimeter to inch:

Press and hold 2ND until 2nd appears on bottom of display and then release. Press and release within 5 seconds.

**NOTE:** MM for millimeter and IN for inch will appear on bottom of display.

### TRAVEL REVERSE:

To change Travel Direction of Reading: Press and hold 2ND until 2nd appears on bottom of display and then release. Press and release HOLD within 3 seconds. **NOTE:** Arrow under measurement mode will show positive direction of spindle travel.

### AUTO OFF:

To turn AutoOff on or off: Press and hold 2ND until 2nd appears on bottom of display and then release. Press and release OFF within 3 seconds. **NOTE:** An hour glass will appear on left side of display if AutoOff feature is active.

### CHANGING RESOLUTION:

To change resolution:

Press and hold 2ND until 2nd appears on bottom of display and then release. Press and release ON/clr within 3 seconds.

Press and release HOLD within 3 seconds

**NOTE:** A # will appear in the right side of the display. 1 = .0005; 2 = .0001; 3 = .00025; 4 = .0005; 5 = .001

Press and release CHNG until desired # is displayed

Press and release CHNG and 2ND simultaneously to save

**NOTE:** Resolution can only be changed to a courser resolution

than the base gauge as purchased.

## **TOTAL RESET:**

To clear all settings and return to factory set defaults:

Press and hold 2ND until 2nd appears on bottom display and then release.

Press and release ON/clr within 3 seconds

Press and release CHNG within 3 seconds

## **Internal Memory**

Digital indicators include internal non-volatile memory to store all factory default and user settings. When the indicator is turned on, user settings and preset numbers will be the same as when the indicator was turned off.

**Note:** Many of the user settings are stored when the indicator is turned off by using the "OFF" key, or when the indicator turns itself off (AUTO OFF). However, if the indicator is turned-off by removing power (disconnecting the AC adapter or cutting power through the Data I/O connector), some or all of the user settings and/or changes may be lost.

## **Maintenance**

Since indicators have precision bearing surfaces, frequent cleaning of the spindle to prevent sluggish or sticky spindle movement is recommended. Although dry wiping of the spindle with a lint free cloth will usually suffice, isopropyl alcohol can be used if necessary to remove gummy deposits. Do not apply any type of lubricant to the spindle.

The bezel and front face can be cleaned using a soft cloth dampened with a mild detergent. Use of aromatic solvents could cause damage. Spindle dust cap and spindle boot are available if the gauge is to be operated in very dirty or abrasive environments.

For digital indicators removal of batteries is highly recommended if the indicator is to be stored or operated on AC adapter power for an extended period of time, to prevent damage to the indicator from battery leakage or corrosion. A periodic check of the batteries for corrosion or leakage is also recommended.



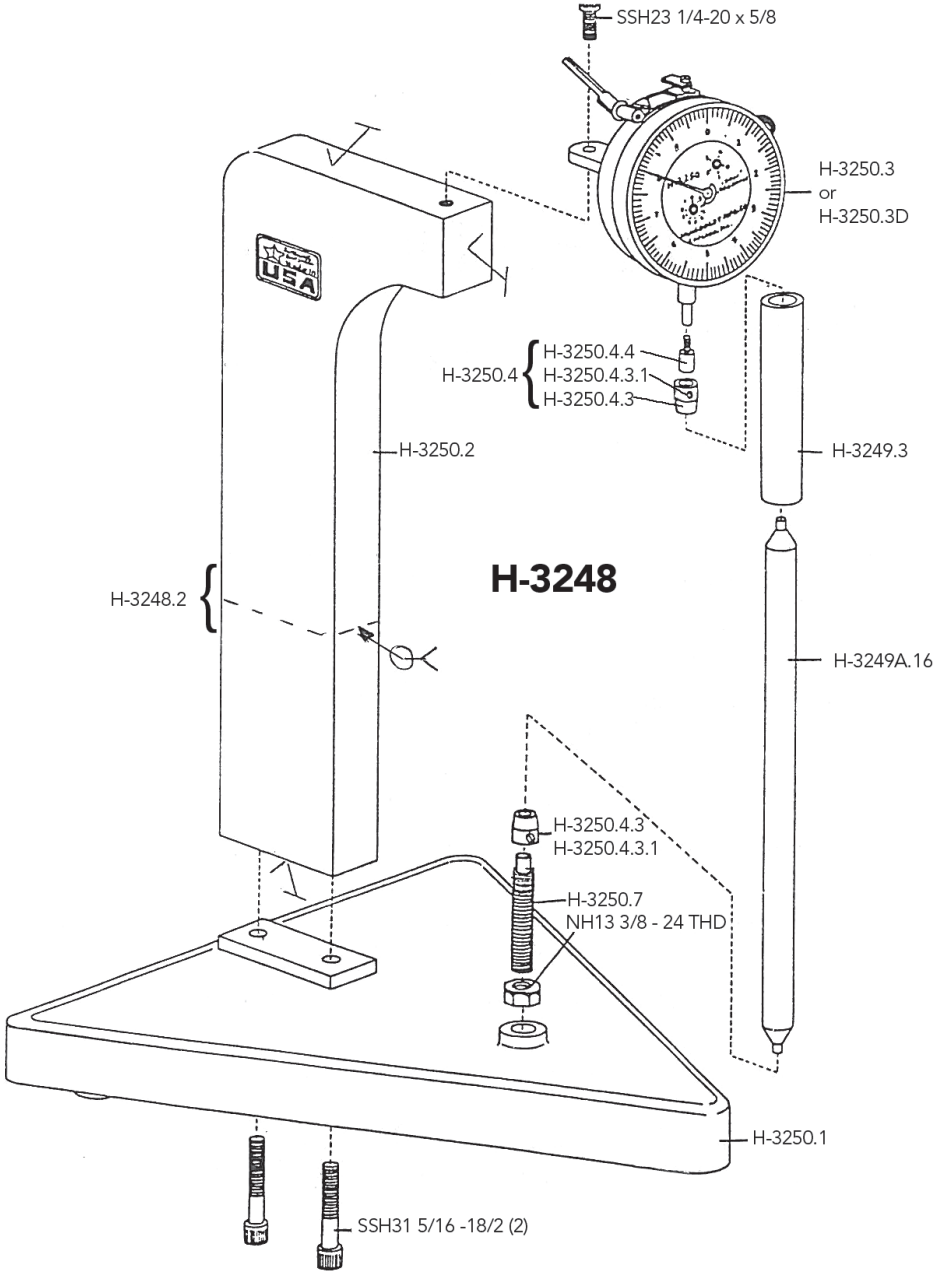

SSH23 1/4-20 x 5/8

H-3250.3  
or  
H-3250.3D

H-3250.4 {  
H-3250.4.4  
H-3250.4.3.1  
H-3250.4.3

H-3249.3

**H-3248**

H-3248.2

H-3250.2

H-3249A.16

H-3250.4.3  
H-3250.4.3.1

H-3250.7  
NH13 3/8 - 24 THD

H-3250.1

SSH31 5/16 - 18/2 (2)

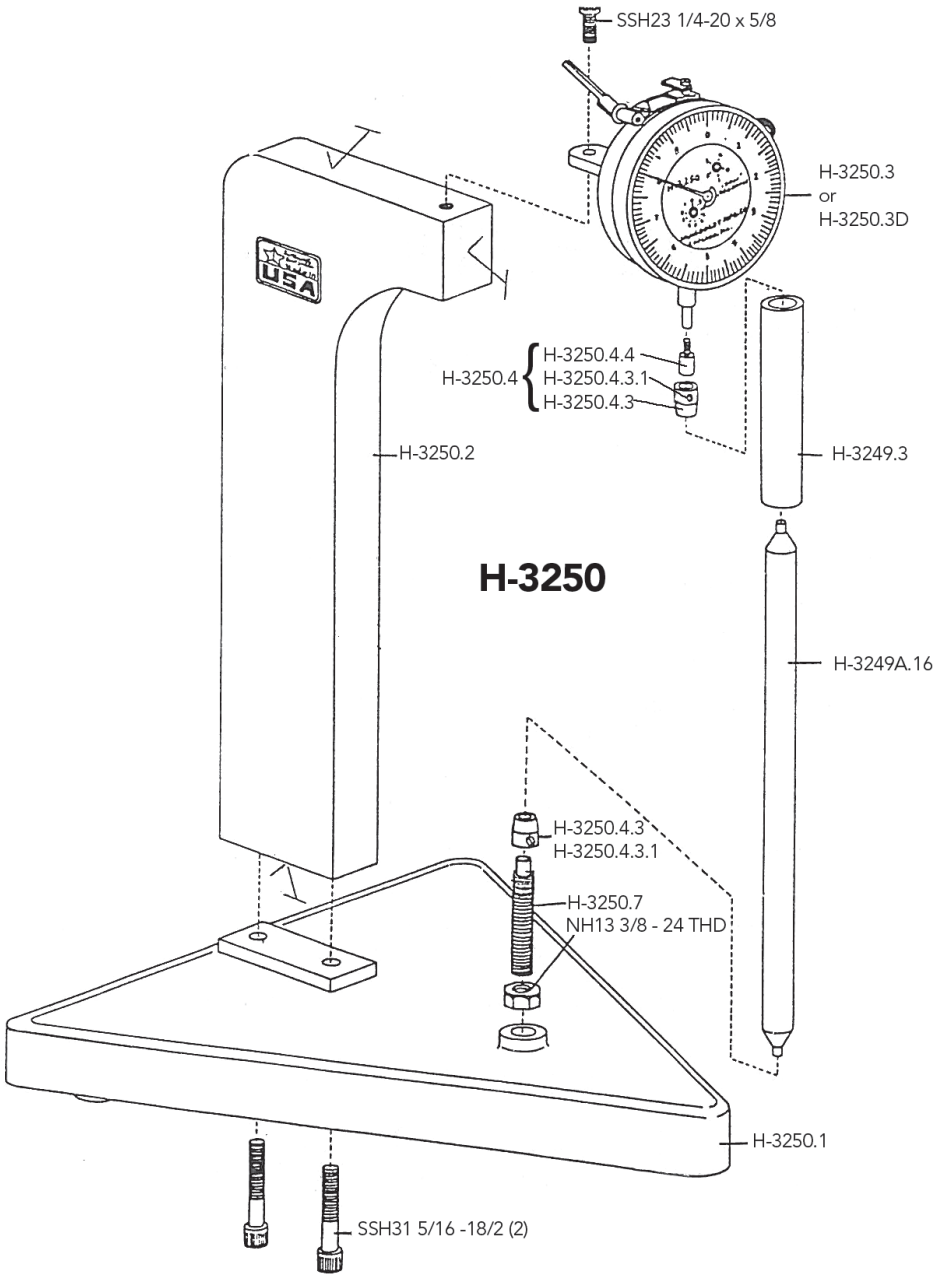

## Replacement Components

Description	Model
Invar Reference Bar for use with H-3250 and 10" (254mm) specimens	H-3249A
Invar Reference Bar for use with H-3248 and 16" (254mm) specimens	H-3249A.16
Dial Indicator	H-3250.3
Digital Indicator	H-3250.3D
Anvil with collar (one each)	H-3250.4
Anvil only	H-3250.4.4
Collar only	H-3250.4.3
Elevating Screw, nut collar & anvil assembly	H-3250.7
Adapter for 5" specimens	H-3250.8



H-3250.8

## Gage Studs— H-3260

Gage Studs have stainless steel contact points and are knurled and threaded for use with cement prism molds. Packaged 10 per bag. Meets ASTM C151, C157, C227, C490; AASHTO M210, T107,

H-3260



**Humboldt Mfg. Co.**

875 Tollgate Road  
Elgin, Illinois 60123 U.S.A.

U.S.A. Toll Free: 1.800.544.7220

Voice: 1.708.468.6300

Fax: 1.708.456.0137

Email: [hmc@humboldtmfg.com](mailto:hmc@humboldtmfg.com)

Testing Equipment for



Construction Materials

**HUMBOLDT**

[www.humboldtmfg.com](http://www.humboldtmfg.com)