



H-3620, H-3624, H-3625



Flow Table
with Mold

Introduction

These Flow Tables are constructed in accordance with the current ASTM Specification C 230, using the inch-pound units for the tables, and for accessory sets of molds and calipers, both inch-pound and metric (SI) units.

Models	Shipping Wt.
H-3624 Flow Table, Motorized, with automatic counter (110V, 60Hz)	108 lbs. (49kg)
H-3624.5F, same H-3624 except (220VAC, 50 Hz, 1 ph) (53.5kg)	118 lbs.
H-3625 Flow Table, Motorized (110V, 60Hz)	100 lbs.(45kg)
H-3625.5F, same as H-3625 except (220 VAC, 50 Hz, 1 ph) (49.9kg)	110 lbs.
H-3620 Flow Table, Hand driven	30 lbs. (13.6kg)

Components and Accessories (ordered separately):

- H-3622 Mold (English)
- H-3622M Mold (Metric)
- H-3621 Caliper (English)
- H-3621M Caliper (Metric)
- H-3623 Circular shield, for use with molds to protect table top from mortar spills.
- H-4144 Straight edge, for cutting off mortar flush with surface of mold.
- H-3614 Automatic counter kit

General Information

Inspection:

Your Flow Table was thoroughly inspected before it was shipped and should be ready to operate after it is properly mounted (see below). Notify Humboldt Mfg. Co. or your local agent and file claim with any carriers involved if you find any damage to the machine.

Physical Specification:

Shipping weight (see above)	
Overall height, table & frame:	9 ¾" (25 cm) approx.
Diameter of table top:	10" (25.4 cm)
Base plate:	10" x 10" x 1" (25.4 x 25.4 x 2.54 cm)

Power Supply:

- 110 VAC 60 Hz 1 phase (H-3624&H-3625), 200 watts
- 220 VAC 50 Hz 1 phase (H-3624.5F&H-3625.5F), 200 watts

Initial Installation

Remove the packing list and verify that all parts have been received. Normally you will receive the product complete in one carton.

It is necessary to mount the base plate to which the flow table is mounted to the top of a concrete pedestal using ½" (13mm) bolts imbedded at least 6" (150mm) into the pedestal. The pedestal is to be cast inverted on the base plate such that positive contact is maintained at all points between the base plate and pedestal (dimensions are as described in ASTM C230).

The motor mounting and supporting plate is attached to the side of the pedestal as shown with 5/16" (8.5mm) imbedded studs or anchored bolts. Use the attached template to mark the hole pattern.

When the concrete is cured insert the proper ½ " (13mm) padding or pads under the pedestal.

After mounting, tighten all fasteners (20 ft. lb. torque or 27 NM) and check to see the able top is level along two diameters in both the raised and lowered positions.

Operation

Depending upon the model purchased operation are the following:

1. By hand (cranking clockwise).
2. By actuating the switch (on the motor line-cord) to the desired count or
3. By presetting and actuating the automatic counter. If the latter, see instructions attached for the H-3614 Automatic Counter Kit.

Prior to an actual test raise and permit the table to drop a dozen times or more just prior to use if it has not been operated in some time.

Perform a calibration test to check for satisfactory operation of the flow table using a suitable calibration material.

Refer to the appropriate ASTM or AASHTO specification for conducting tests, e.g., for testing the Air Content of Hydraulic Cement Mortar follow the procedure outlined in the current issue of ASTM Specification C185.

CAUTION: Keep hands, clothing and other objects away from moving parts when the machine is in operation.

Maintenance

The table top and vertical shaft must be kept clean and the vertical shaft lightly lubricated with a light oil (SAE-10), which must not flow into the mating frame and table top surfaces.

To facilitate easy starting and reduce wear apply a light film of oil to the crown of the cam, being careful to keep it off of the mating frame and table top surfaces.

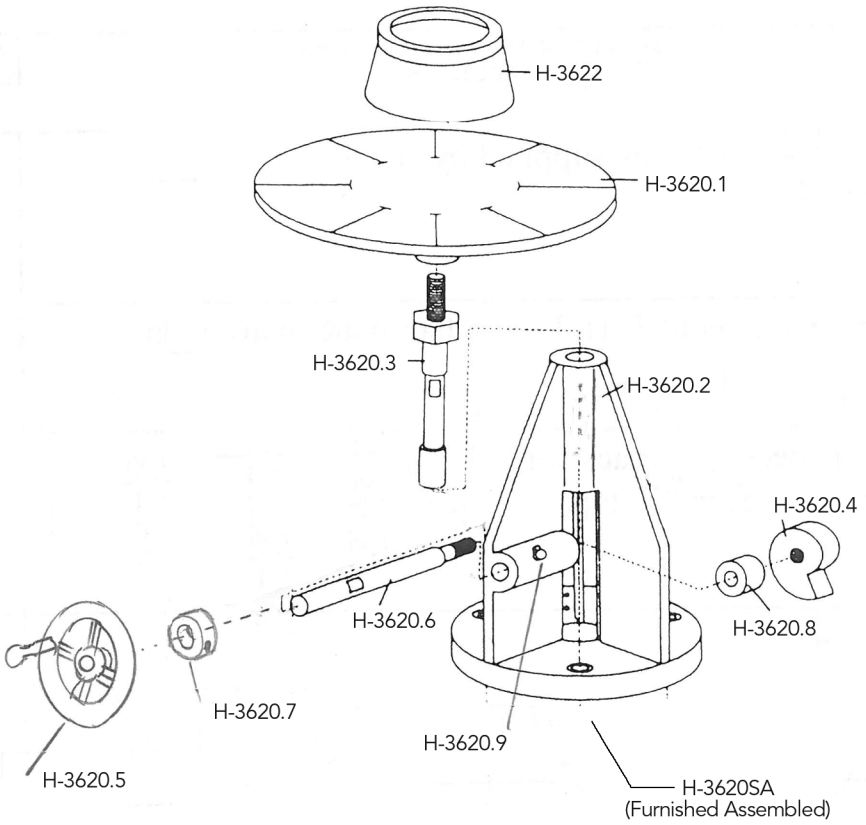

H-3620

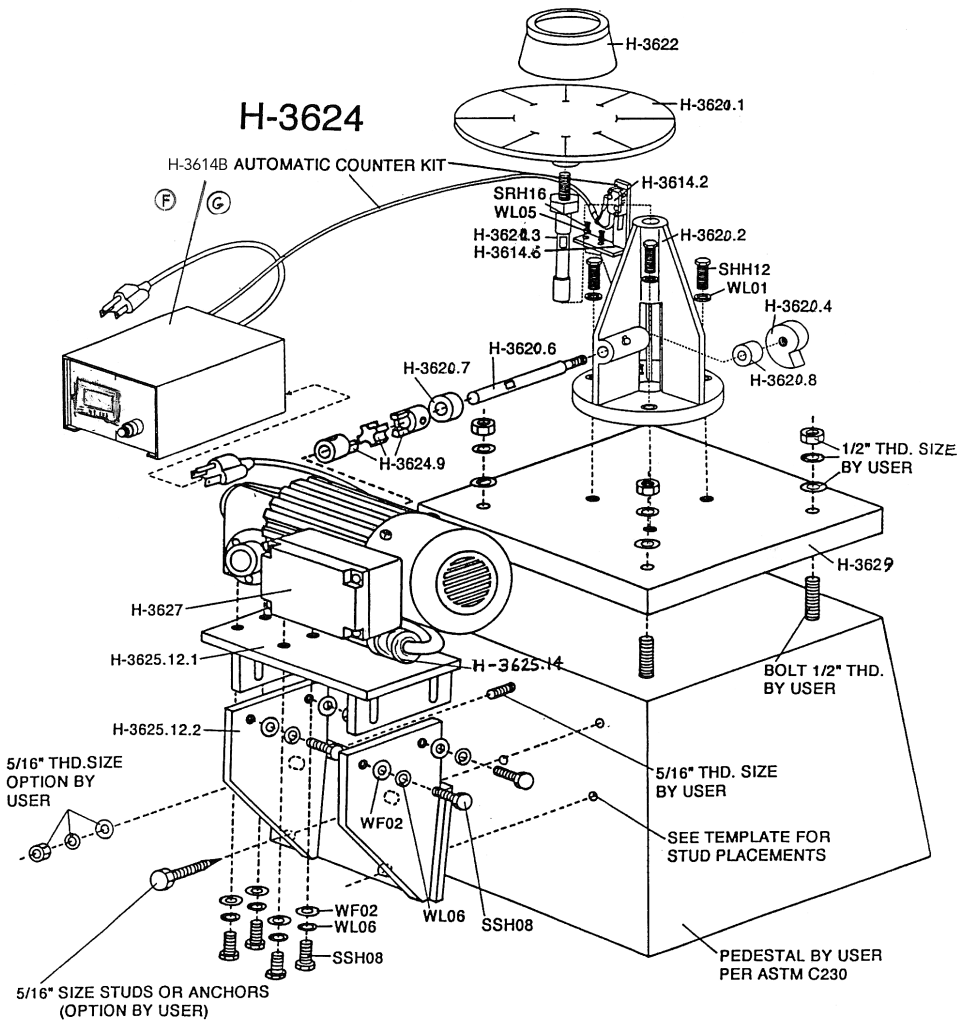

H-3624

H-3625

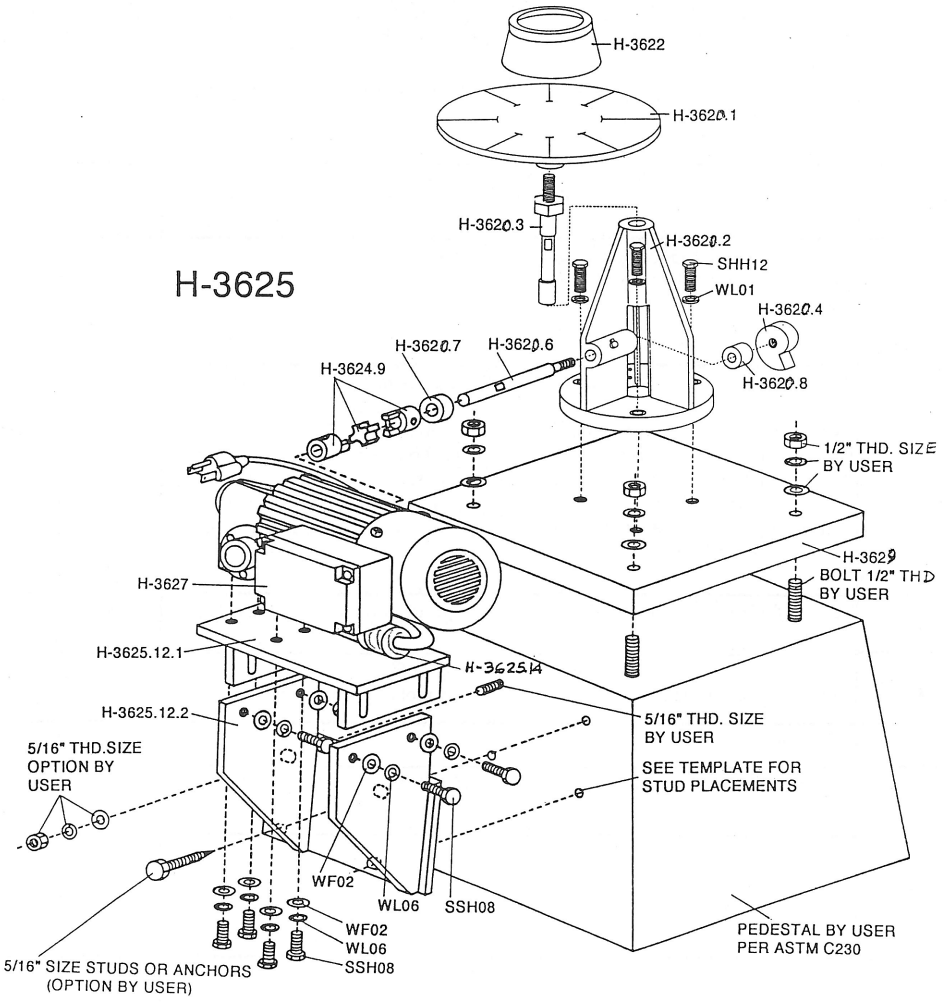

H-3625

Warranty

Humboldt Mfg. Co. warrants its products to be free from defects in material or workmanship. The exclusive remedy for this warranty is Humboldt Mfg. Co., factory replacement of any part or parts of such product, for the warranty of this product please refer to Humboldt Mfg. Co. catalog on Terms and Conditions of Sale. The purchaser is responsible for the transportation charges. Humboldt Mfg. Co. shall not be responsible under this warranty if the goods have been improperly maintained, installed, operated or the goods have been altered or modified so as to adversely affect the operation, use performance or durability or so as to change their intended use. The Humboldt Mfg. Co. liability under the warranty contained in this clause is limited to the repair or replacement of defective goods and making good, defective workmanship.

Humboldt Mfg. Co.
875 Tollgate Road
Elgin, Illinois 60123 U.S.A.

U.S.A. Toll Free: 1.800.544.7220
Voice: 1.708.468.6300
Fax: 1.708.456.0137
Email: hmc@humboldtmfg.com

Testing Equipment for



Construction Materials

HUMBOLDT

www.humboldtmfg.com