



Compaction
Permeameters

General

The H-4145 and H-4146 Permeameters are designed for performing either constant head or falling head permeability tests on undisturbed, remolded or compaction soils. The units consist of a standard compaction mold and collar, mounting base with porous stone and brass pipe fitting and head with air escape valve and fitting.

Sample Preparation

For tests on cohesionless soils, such as sands and gravels the soils are placed in to the mold by a spoon or any other desired method. To avoid entrapped air it is advisable to raise the water level in the cylinder as the soil is placed, maintaining about one inch of free water above the surface of the sample. If the sample contains fines, care must be exercised to avoid segregation. After the material has been placed and is at the proper voids ratio the collar is removed and the test head and gasket are set in position and tightened.

For tests on remolded, compacted soils such as silts and clays, the cylinder and the collar are mounted on a compaction test base and the sample is compacted as per Standard Proctor Method or other method applicable to the desired test results. With the specimen properly compacted, the collar should be removed and the upper surface of the soil squared with the end of the cylinder. The cylinder and soil are then placed on the permeameter base and the head fastened in place. Care must be taken to keep air out of the system at all stages of preparation for the test.

For tests on undisturbed soil samples, the specimen is trimmed to fit the cylinder without air space between soil and the wall. If this is impossible, the sides of the sample should be sealed with paraffin and the sample fitted to the cylinder. The cylinder is then placed on the permeameter base and the head fastened in place.

For tests on rock samples (rock cores), the sides are coated with paraffin in order to fit tightly in the cylinder. With this completed the cylinder is placed on the permeameter base and the head fastened in place.

Test Instructions

Constant Head Test—This test is generally used for determining permeability of materials, such as sands, gravels, etc. A constant head supply can be adjusted to give the desired hydraulic gradient. This discharge can be conveniently collected in a 100cc graduate. A stop watch is required for timing the discharge period.

Falling Head Test—For soils with low permeability, the falling head test is most applicable. The drain at the base is connected to a tank, which will give the tail water elevation. The falling source is connected to the pipe fitting at

the head and the valve opened to remove all air from the system, the valve is closed after air removal. If a small pressure head is sufficient, the elevation of the water in a pipette may be taken as the headwater elevation. If a large pressure head is required, constant air pressure may be introduced at the top of the pipette and this air pressure head added to the pipette head. When a very high pressure head is used it is usually sufficiently accurate to average the start and finish heads and to calculate the permeability, as in the constant head test. For tests in which it is desired to maintain a high hydrostatic pressure, but a small difference in pressure head, i.e. simulating underground low depth pressures, two pressure tanks on at each end may be used. One would become the head pressure and the other the tail pressure.

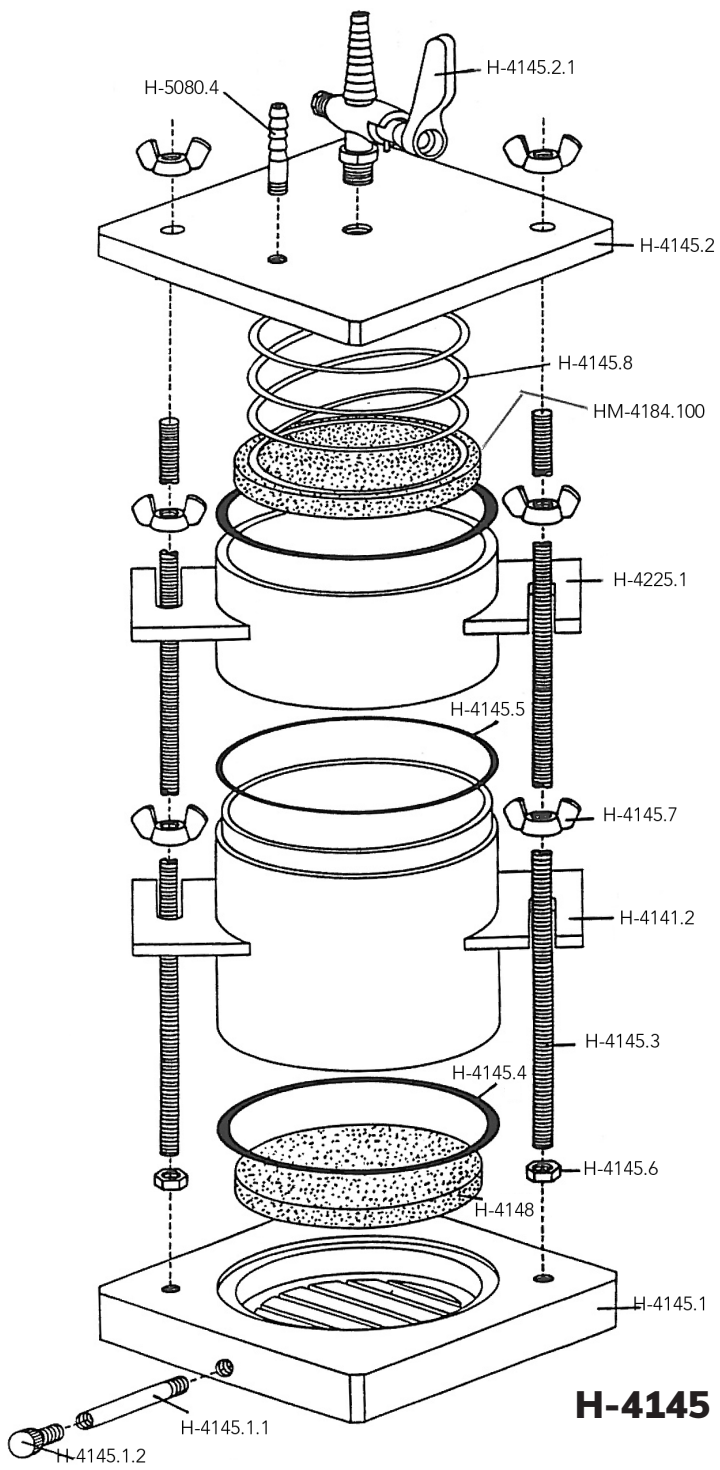

H-4145

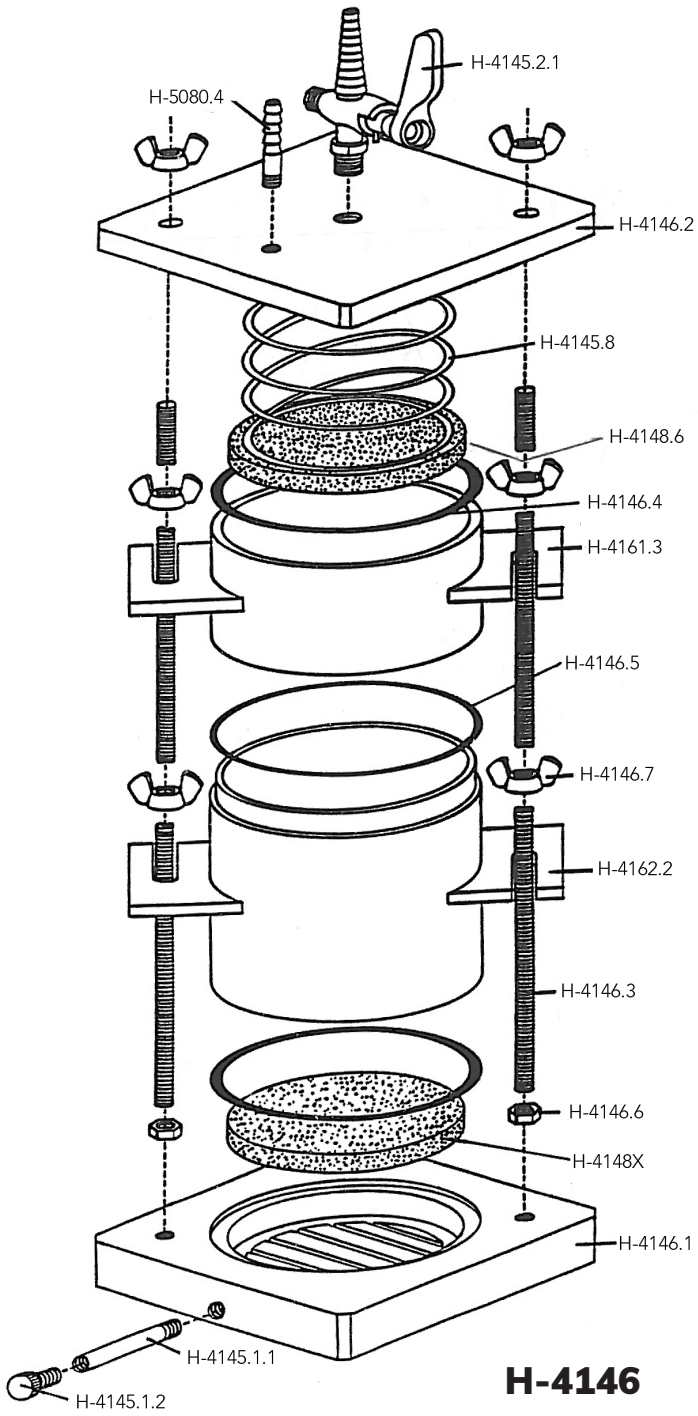

H-4146

Warranty

Humboldt Mfg. Co. warrants its products to be free from defects in material or workmanship. The exclusive remedy for this warranty is Humboldt Mfg. Co., factory replacement of any part or parts of such product, for the warranty of this product please refer to Humboldt Mfg. Co. catalog on Terms and Conditions of Sale. The purchaser is responsible for the transportation charges. Humboldt Mfg. Co. shall not be responsible under this warranty if the goods have been improperly maintained, installed, operated or the goods have been altered or modified so as to adversely affect the operation, use performance or durability or so as to change their intended use. The Humboldt Mfg. Co. liability under the warranty contained in this clause is limited to the repair or replacement of defective goods and making good, defective workmanship.

Humboldt Mfg. Co.

875 tollgate Road
Elgin, Illinois 60123U.S.A.

U.S.A. Toll Free: 1.800.544.7220

Voice: 1.708.468.6300

Fax: 1.708.456.0137

Email: hmc@humboldtmfg.com

Testing Equipment for



Construction Materials

HUMBOLDT

www.humboldtmfg.com