



Vane Inspection Kit

Introduction

The inspection vane is used to measure in-situ undrained shear strength in clays. It is primarily intended for use in trenches and excavations at depths up to 3m. This can be extended with additional optional extensions.

The range of the instrument is from 0 to 260kPa when three different size vanes are used. Accuracy should be within 10% of the reading.

Description

The measuring part of the instrument is a spiral-spring, (max. torque transmitted 30 kgcm). When the handle is turned, the spring deforms and the upper part and the lower part of the instrument get a mutual angular displacement. The size of this displacement depends on the torque required to turn the vane. By means of a graduated scale shear strength of the clay is obtained.

The lower and upper halves of the instrument are connected by means of threads. The scale is also supplied with threads, and follows the upper part of the instrument by means of two lugs. The O-point is indicated by a line on the upper part. When torque is applied, the scale-ring follows the upper part of the instrument, and when failure in the clay is obtained, the scale-ring will remain in its position due to the friction in the threads.

Four sizes of four-bladed vanes are supplied:

20 x 40mm (standard): Reading is direct-Range is 0 to 130kPa (1.3 TSF)

16 x 32mm (extra vane): Multiply reading by 2-Range is 0 to 260kPa (2.6 TSF)

25.4 x 50.8 (extra vane): Multiply reading by 0.5-Range is 0 to 65kPa (0.65 TSF)

50.8 x 101.6mm (extra vane):, Multiply reading by 0.0625-Range is 0 to 8.125kPa (0.08TSF).

- Note that each mark on graduated scale equals 1kPa. Therefore, the mark 1 actually represents 10kPa when using the standard (20 x 40mm) vane. The maximum possible reading is 130kPa using the standard vane and 260kPa when using the smallest (16 x 32mm) vane.

The "area ratio" of the vanes are 14, 16.5 and 24% (ratio of cross sectional area of vane to the area to be sheared).

The vane blades are soldered to a vane-shaft, which can be extended by one or more 0.5m long rods. The connection between the shaft-rods and the instrument is made by threads. To make the connection as straight as possible, the rods have to be screwed tight together and with threads free from dirt.

The maximum shear strength that can be measured with the inspection vane is 260kPa. In clays with this shear strength, a force of about 40 to 50 kilos is required to press the vane down into the clay. The vane-shaft is designed to take this -force, but if extension rods are used, precautions against buckling

are suggested.

Working Instructions

General Procedure

1. Connect required vane and extension rods to the inspection vane instrument
WHILE SCREWING VANE OR RODS TO INSTRUMENT, HOLD ONTO LOWER PART of the instrument.
2. Push vane into the ground to the required position.
MAKE NO TWISTING MOTION TO VANE DURING PENETRATION.
3. Make sure that the graduated scale is set to 0 position.
4. Turn handle clockwise.
TURN AS SLOWLY AS POSSIBLE WITH CONSTANT SPEED.
5. When the lower part moves at same rate as upper part (4) around or even falls back, failure has occurred and maximum shear strength has been attained in the clay at the vane.
6. Holding handle firmly, allow it to return to zero-position.
DO NOT ALLOW THE HANDLE TO SPRING BACK as damage to mechanism could occur.
7. Note the reading on the graduated scale.
DO NOT TOUCH OR IN ANY WAY DISTURB THE POSITION OF THE GRADUATED RING UNTIL THE READING IS TAKEN.
8. Record the reading together with position of hole and depth.
9. Turn the graduated scale counter-clockwise back to 0 position.
10. To determine the remolded shear strength, the following procedure is used: Turn the vane quickly at least 25 revolutions. Zero the scale and take at least two measurements by turning the instrument as slowly as possible. The minimum value is considered the correct one.
11. Push the vane down to next position. If necessary add on another extension rod.
12. Repeat the above measurement procedure (3-10).
13. When the last reading is taken pull the vane up. If the clay is comparatively soft, this can be done by hand, gripping the handle. In harder clays, some mechanical device might be necessary. It is then advisable to remove the instrument and pull the rods directly.

Special Procedure

When measuring the shear strength at greater depths, friction between the clay and the extension rods can be appreciable and must be taken into consideration.

To measure this friction, extension rods and a vane-shaft without vane (dummy) are pushed into the ground to the depths required for shear force measurements. Friction is then measured in the same way as when using vanes (above 3-9). The friction-value obtained is deducted from the measured shear strength to determine the actual shear strength. To penetrate through firm layers, a preboring using a rod with the same diameter as the vane may be helpful.

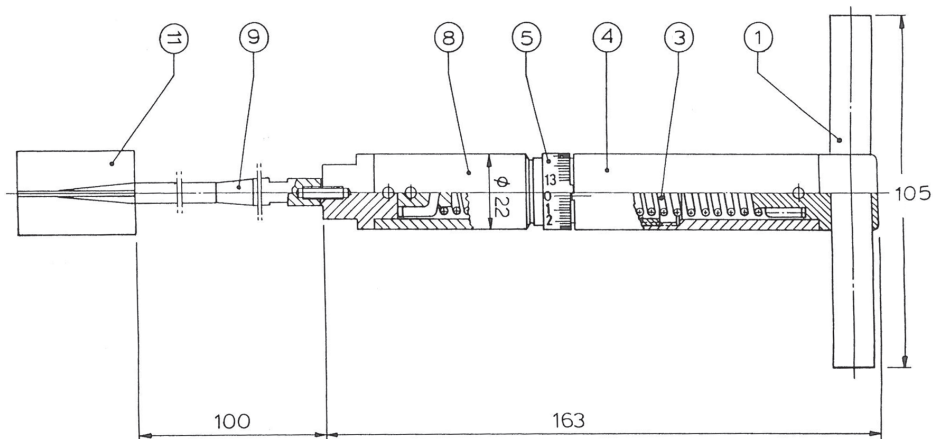

Warranty

Humboldt Mfg. Co. warrants its products to be free from defects in material or workmanship. The exclusive remedy for this warranty is Humboldt Mfg. Co., factory replacement of any part or parts of such product, for the warranty of this product please refer to Humboldt Mfg. Co. catalog on Terms and Conditions of Sale. The purchaser is responsible for the transportation charges. Humboldt Mfg. Co. shall not be responsible under this warranty if the goods have been improperly maintained, installed, operated or the goods have been altered or modified so as to adversely affect the operation, use performance or durability or so as to change their intended use. The Humboldt Mfg. Co. liability under the warranty contained in this clause is limited to the repair or replacement of defective goods and making good, defective workmanship.

Humboldt Mfg. Co.

875 Tollgate Road
Elgin, Illinois 60123 U.S.A.

U.S.A. Toll Free: 1.800.544.7220

Voice: 1.708.468.6300

Fax: 1.708.456.0137

Email: hmc@humboldtmgf.com



Testing Equipment for

Construction Materials

HUMBOLDT

www.humboldtmgf.com