



3-Cell Manual Control Panel

INTRODUCTION

The HM-4165 Pressure Control/Distribution Panel is designed to control cell and back pressure outputs for up to three triaxial cells. A digital pressure display allows the monitoring of the pressure of each output individually. The HM-4165 panel includes the air and water distribution capabilities including tap water, as well as de-aerated water. The panel also controls the vacuum necessary to remove air from the tap water in the de-airing tank. The digital pressure gauge is powered by an AC to DC transformer and a 110/220 VAC power source is required. A supply of compressed air is necessary, as well as vacuum, tap water, and a drain to allow water to be removed from the test apparatus.

INSTALLATION

The HM-4165 is a simple bench mounted system, which requires no fixed mounting.

PANEL MOUNTING

A pair of supporting feet is supplied with the panel so that it can be bench mounted and remain stable. Screws, nuts, and washers for the support feet are supplied so that the support feet can be attached as shown in Figure 1.

AIR/WATER CONNECTIONS

All connections will require either 1/4 inch OD or 1/8 inch OD flexible tubing. However, metric adapters are available to allow connecting the 1/4 inch tubing to 6 mm tubing.

PANEL CONNECTIONS

The panel is equipped with push-to-connect-style fittings on the back side of the panel frame. It is necessary to use 1/4" OD flexible tubing to make the connections. Figure 2 shows how the connections are to be made with air and water sources, as well as connections to the triaxial cell and other equipment. The panel is designed to accommodate 3 triaxial test apparatuses simultaneously. However, only the connections for one triaxial test apparatus are shown in the figure. The two remaining test apparatuses connect to their respective connection locations. Insert the tubing into the fittings. The seal in the fitting will resist the tubing and a little extra force will be required to get the tubing to pass through the seal in the fitting. To make sure the fitting is in all the way, lightly pull on the tubing. If it comes out of the fitting, it was not inserted completely. While facing the back of the panel, the four connections starting from the left are for the water drain, tap water

2

input, vacuum input, and compressed air input respectively. The last three connections are for de-aerated water return from the de-airing tank, tap water going to the de-airing tank, and air/vacuum to the de-airing tank respectively.

On the face of the panel are the connections for air pressure outputs to the HM-4151A Bladder Air/Water Cylinders for cell pressure and back pressure, tap water and de-aerated water for the bladder cylinders, automatic volume change, and the triaxial cell. Also, there is an auxiliary pressure connection for air pressure up to 10 psi and an auxiliary vacuum connection. These connections are made using quick disconnect style fittings. These fittings have a barbed end and a nut which fits over the tubing to clamp the tubing on to the barbed end of the fitting.

To disconnect the fittings from the panel, push down on the tab at the top of the socket half of the fitting as shown in Figure 3. The plug half of the fitting will pop outward. To reconnect it, just push the plug into the socket until the tab clicks and locks the plug in place. The connection for the tap water to the base of the sample via the volume change device requires a 1/4" to 1/8" push-to-connect adapter to allow the attachment of 1/4" tubing from the panel to the 1/8" OD tubing which connects to the volume change device. This adapter is supplied with the panel.

BLADDER CYLINDER CONNECTION

The bladder cylinders have push to connect style fittings at the bottom of the assembly. These fittings use the 1/4 inch OD tubing and attach the by the same method as the fittings on the back side of the panel. The center fitting is for air pressure from the right side of the panel. The other push-to-connect fitting is for water from the connections on the front of the panel. There are two bladder cylinders required per triaxial cell. One bladder cylinder is for cell pressure and tap water supply, the other cylinder is for back pressure and de-aerated sample water supply. The air pressure line for one of the bladder cylinders will connect to the Cell air pressure connection on the front of the panel and the water line for that bladder cylinder will connect to the Bladder A connection on the front of the panel. The air line for the second bladder cylinder will connect to the pore water pressure (PWP) connection on the front of the panel and the water line for the second bladder cylinder will connect to the Bladder B connection on the front of the panel as shown in Figure 2.

AUTO VOLUME CHANGE CONNECTION

The Automatic Volume Change Device has push-to-connect fittings for

3

1/8" OD tubing. The volume change device is connected to the panel at the Base connection on the front of the panel as shown in Figure 2. The connection for the tap water to the base of the sample via the volume change device requires a 1/4" to 1/8" push-to-connect adapter to allow the attachment of 1/4" tubing from the panel to the 1/8" OD tubing which connects to the volume change device. This adapter is supplied with the panel.

TRIAxIAL CELL CONNECTION

The triaxial cell has compression fittings on the front as shown in Figure 4. The cell connection on the triaxial cell connects to the water connection at the Cell connection on the front of the panel. The base connection on the triaxial cell connects to the volume change device as shown in Figure 2 and not directly to the panel.

DE-AIRING TANK CONNECTION

The de-airing tank has connections for the tap water in, de-aerated water out, and air/vacuum lines. These lines connect to the back side of the panel at the corresponding push-to-connect fittings as shown in Figure 2.

ELECTRICAL CONNECTION

The only electrical connection required is to connect the AC to DC transformer into the back of the digital display and then plug the transformer into a 110/220 VAC electrical socket as in Figure 5.

OPERATION

After making all of the necessary connections, check to make sure all of the valves on the front of the panel are set to the off position. Also, loosen the jam nuts on the regulators as shown in Figure 3.

AIR PRESSURE ADJUSTMENT

There are a total of seven regulators on the panel. The main regulator, located below the gauge labeled SYSTEM AIR PRESSURE, controls the supply of air for all of the other regulators. There are six regulators on the front of the panel near the center which control the output pressure to the bladder cylinders for cell pressure and back pressure control. There is also a small regulator at the front of the panel in the upper right corner labeled AUXILIARY AIR PRESSURE. This regulator is used to control up to 10 psi of pressure to assist in the purging of water either from the triaxial cell or from the de-airing tank. This regulator has a locking knob which must be pulled out to adjust the pressure or pushed in to lock it into position.

AIR/WATER CONTROL VALVES

There are several control valves on the panel for on/off operation of the air and water control.

There are two valves under the De-Airing Tank heading (Figure 6). These valves control flow of water to and from the de-airing tank and air or vacuum to the tank. The water flow valve either allows tap water to fill the tank or allows the tank to be drained for cleaning and maintenance. The other valve is for the application of vacuum to the de-airing tank to remove air from the water in the tank and it also allows compressed air to be pumped into the tank to assist in draining the water from the tank. The small auxiliary regulator controls the amount of pressure to assist in draining the water from the de-airing tank. Set the desired pressure by turning the knob on the auxiliary regulator in the clockwise direction. NOTE: These valves must be in the off position during a test.

There are three valves under the AIR CONNECTION heading (Figure 7) on the front of the panel (one valve per triaxial cell). These valves connect the digital display to the corresponding regulators so that the pressure for any individual air line can be displayed one at a time. When the valve is in the off position, the pressure is still controlled by the regulator. NOTE: When the pressure is displayed for one of the cell air connections, the other cell air valves must be in the OFF position or else the incorrect pressure will be displayed.

There are six valves under the WATER CONNECTION heading. There are two valves for each triaxial cell apparatus which are used to control the flow of tap water to the cell and to the corresponding bladder cylinder and also de-aerated water to the Auto Volume Change and to the other bladder cylinder in the apparatus (Figure 8). When the valve is in the FILL position, water flows to the cell and bladder cylinder at the same time, or to the second bladder cylinder and to the Auto Volume Change at the same time. The CELL valve has drain position which allows water to be drained from the cell. NOTE: These valves should be in the off position during a test. The valve is in the off position when the knob is pointed to the left.

PRESSURE GAUGES

There are two pressure gauges on the panel. The gauge at the upper left side is used to monitor the pressure regulated by the main pressure input regulator. It is a mechanical gauge and requires no electrical source. The other gauge has a digital display and is used to monitor the air pressure in the bladder cylinders which control the pressure in the cell and the back pressure in the sample. To operate this gauge, it must first be connected to an AC power source. It has an On/Off button on the left side of the display.

AIR FILTER

There is an in-line air filter which filters the incoming air from the compressed air source. It also traps water and other fluids in the line.

MAINTENANCE

There is very little maintenance required. The digital gauge operates with AC power. If the gauge fails to operate, first check the transformer to determine if it is operational.

The air filter should be checked every day to determine if the white filter element is dirty or if fluid must be drained from the clear plastic bowl. To remove water or fluids from the bowl, turn the black knob at the bottom of the clear plastic bowl. To purge the fluids from the bowl, turn the knob as if tightening a right handed screw and the fluids will drain out of the bottom. To close it, turn the knob as if loosening the screw.

Caution: The filter may be under pressure. If so, the fluids will spray out at high velocity.

If the filter becomes dirty and clogged, open the drain plug as described above to relieve pressure. Remove the bowl by rotating the bowl counterclockwise to unscrew it from the filter body. Be careful not to lose or damage the o-ring that seals the bowl to the body of the filter. Next, unscrew the filter support by turning it clockwise until it comes off. Slide the filter element off of the support and replace it with a new filter. Reassemble the air filter assembly in the reverse order.

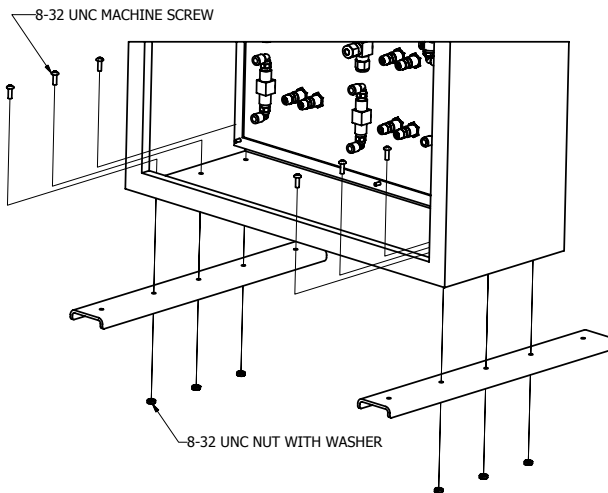

Figure 1: Mounting Feet Assembly

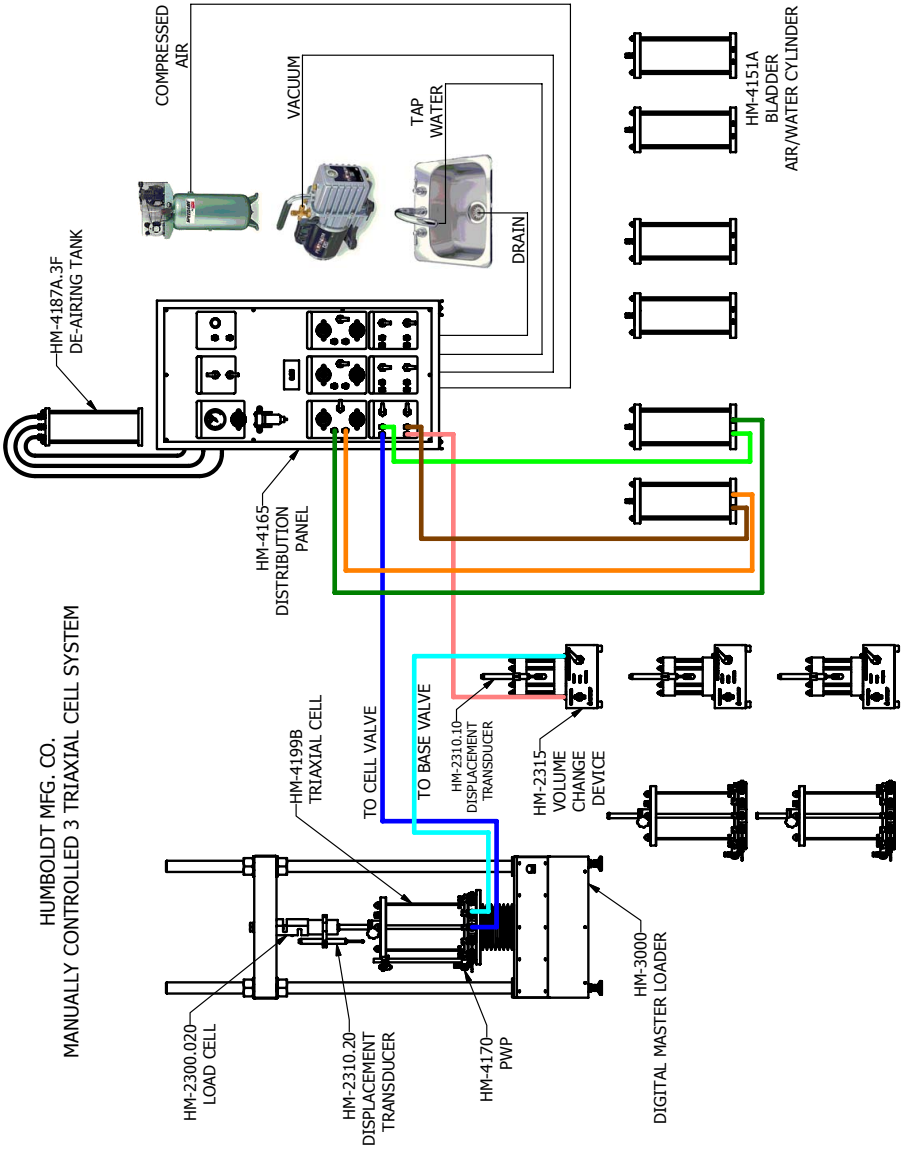

Figure 2

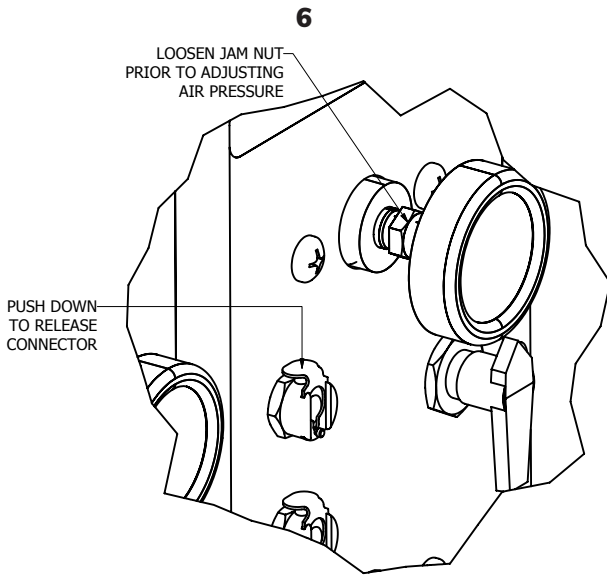

Figure 3

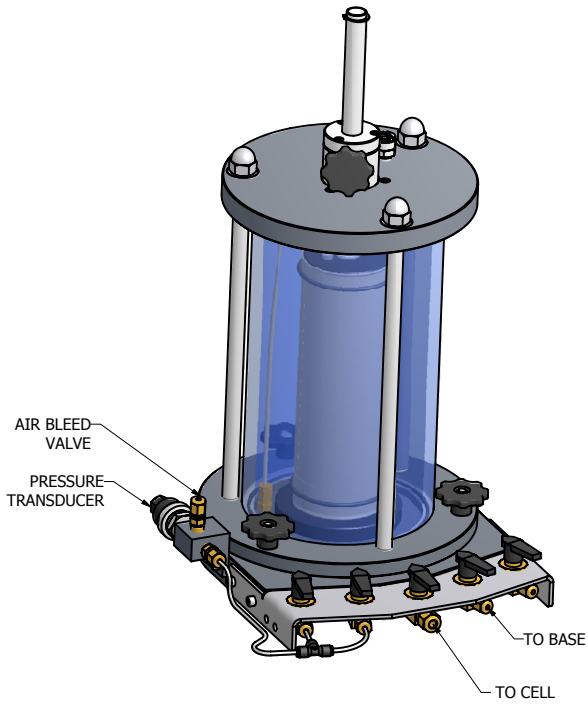

Figure 4 Triaxial Cell

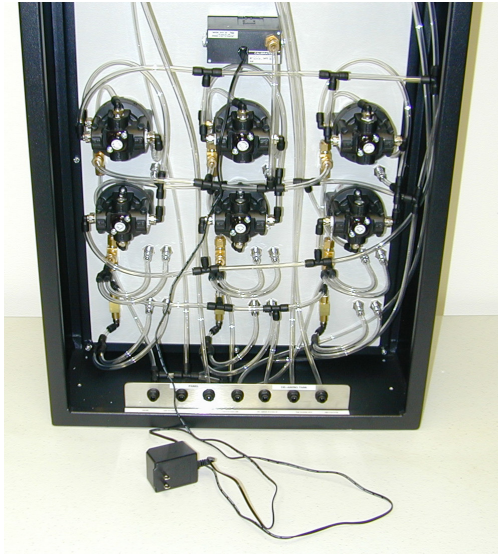

Figure 5

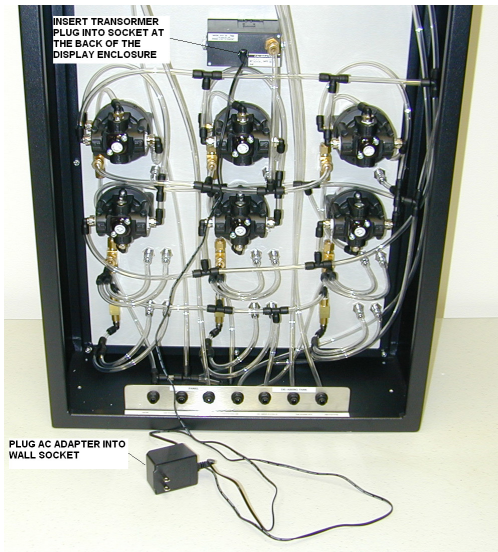

Figure 5B

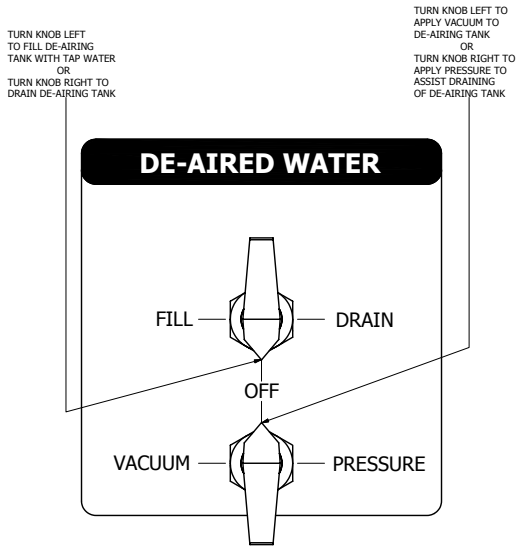

FIGURE 6
DE-AIRING TANK CONTROL VALVES

Figure 6

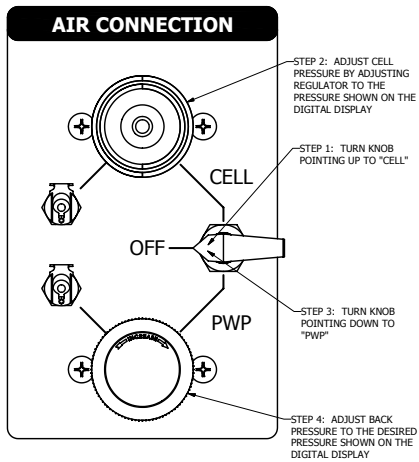

FIGURE 7
CELL AND BACK PRESSURE CONTROLS

Figure 7

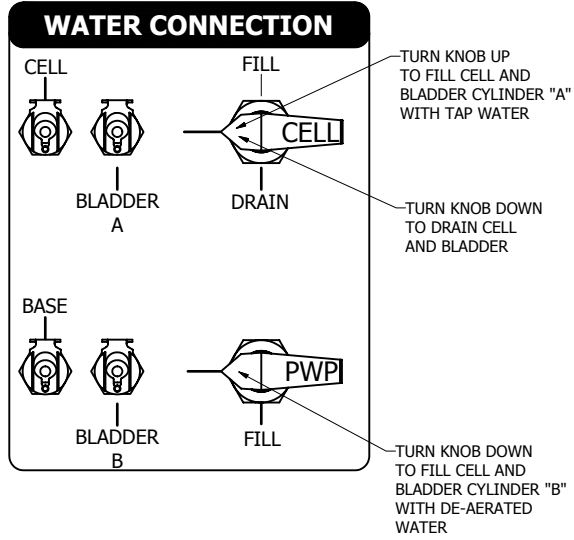

FIGURE 8
CELL AND SAMPLE BASE WATER CONTROLS

Figure 8

Wilkerson Lubricators and Filters

Pneumatic Division
 Richland, Michigan 49083
 269-629-5000

Installation & Service Instructions:
1M103G

**Miniature Series
 Micro-Mist Lubricators &
 Particulate Filters**

ISSUED: November, 2003
Supersedes: September, 2000
 Doc.# 1M103, ECN# 030539, Rev. 8

⚠ WARNING

To avoid unpredictable system behavior that can cause personal injury and property damage:

- Disconnect electrical supply (when necessary) before installation, servicing, or conversion.
- Disconnect air supply and depressurize all air lines connected to this product before installation, servicing, or conversion.
- Operate within the manufacturer's specified pressure, temperature, and other conditions listed in these instructions.
- Medium must be moisture-free if ambient temperature is below freezing.
- Service according to procedures listed in these instructions.
- Installation, service, and conversion of these products must be performed by knowledgeable personnel who understand how pneumatic products are to be applied.
- After installation, servicing, or conversion, air and electrical supplies (when necessary) should be connected and the product tested for proper function and leakage. If audible leakage is present, or the product does not operate properly, do not put into use.
- Warnings and specifications on the product should not be covered by paint, etc. If masking is not possible, contact your local representative for replacement labels.

Introduction

Follow these instructions when installing, operating, or servicing the product.

Application Limits

These products are intended for use in general purpose compressed air systems only.

Operating Inlet Pressure:

	kPa	PSIG	bar
with Polycarbonate Bowl	1000	150	10.3
with Metal Bowl	1700	250	17.0

NOTE: The maximum recommended pressure drop for a particulate filter is 70 kPa (10 psig, 0.7 bar)

Ambient Temperature Range:

with Polycarbonate Bowl	0°C to 52°C (32°F to 125°F)
with Metal Bowl	0°C to 80°C (32°F to 175°F)

ANSI Symbols



Micro-Mist Lubricators (Figure 1)

Description

These micro-mist lubricators are designed to deliver an atomized oil mist to air operated tools, motors, and other pneumatic equipment. Units are equipped with full-view sight glass for visual indication of oil drop rate, needle valve feed adjustment to regulate oil drop rate, and a venturi bypass disc to compensate for changes in air flow demands.

Installation of Lubricator

1. Lubricator should be installed with reasonable accessibility for service whenever possible - repair service kits are available. Keep pipe and tubing lengths to a minimum with inside clean and free of dirt and chips. Pipe joint compounds should be used sparingly and applied only to the male pipe - never into the female port. Do not use PTFE tape to seal pipe joints - pieces have a tendency to break off and lodge inside the unit, possibly causing malfunction.
2. Install lubricator so that air flow is in the direction of arrow on body.
3. Installation should be upstream from, and as close as possible, to the device it is to lubricate (valve, cylinder, tool, etc.). Whenever possible, avoid locations that require air-borne oil to move in an upward direction to reach the device to be lubricated.
4. The installation of an individual lubricator for each air consuming device provides best assurances of proper lubrication.

5. In new installations, it is good practice to "wet down" the inside diameter of piping and those with oil before making final connections. Although your lubricator delivers oil to the line, pre-coating the inside diameter with oil helps insure that proper amounts of oil are delivered to the point of application.

Operation & Service of Lubricator

⚠ Warning: Before filling, inlet pressure must be eliminated and then de-pressurize system pressure.

1. **FILLING** - After de-pressurizing system, remove fill plug or bowl to refill lubricator. Fill bowl to fill line indicated on the bowl with oil of 150 to 200 SSU at 100°F viscosity - same as SAE No. 10 (petroleum based hydraulic oils or spindle oils are good examples). DO NOT USE OILS WITH TACKY ADDITIVES, COMPOUND OILS CONTAINING SOLVENTS, GRAPHITE, SOAPS OR DETERGENTS. (Automotive oils generally contain detergents and are not recommended).
2. Replace the fill plug or bowl and seal firmly. Excessive torque is not necessary. The lubricator is now ready for setting.
3. **OIL DELIVERY ADJUSTMENT** - To adjust oil delivery, turn the adjusting needle on top of the lubricator.

Leaner - Clockwise Richer - Counterclockwise

By counting the number of drops per minute in the sight dome, you can adjust lubricator to your required setting. Approximately 3% of the droplets visible in the sight dome go downstream; adjust drip rate accordingly. Consult oil delivery conversion chart (see below).

Generally, one drop per minute downstream for every 10-15 SCFM flow is satisfactory, 25 drops per minute equals one ounce per hour - volume of oil passing through the sight dome.

NOTE: This is a constant density type lubricator which delivers a constant ratio of oil to air flow. Therefore, if air flow increases or decreases, oil delivery will be effected proportionately. ONLY IF DIFFERENT RATIO IS DESIRED NEED YOUR NEEDLE VALVE SETTING BE CHANGED AFTER YOUR INITIAL SETTING.

Oil Delivery Conversion

3% of Drip Rate to Downstream

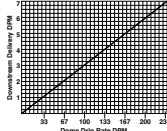

⚠ WARNING

FAILURE OR IMPROPER SELECTION OR IMPROPER USE OF THE PRODUCTS AND/OR SYSTEMS DESCRIBED HEREIN OR RELATED ITEMS CAN CAUSE DEATH, PERSONAL INJURY AND PROPERTY DAMAGE.

This document and other information from The Company, its subsidiaries and authorized distributors provide product and/or system options for further investigation by users having technical expertise. It is important that you analyze all aspects of your application, including consequences of any failure and review the information concerning the product or systems in the current product catalog. Due to the variety of operating conditions and applications for these products or systems, the user, through its own analysis and testing, is solely responsible for making the final selection of the products and systems and assuring that all performance, safety and warning requirements of the application are met.

The products described herein, including without limitation, product features, specifications, designs, availability and pricing, are subject to change by The Company and its subsidiaries at any time without notice.

EXTRA COPIES OF THESE INSTRUCTIONS ARE AVAILABLE FOR INCLUSION IN EQUIPMENT / MAINTENANCE MANUALS THAT UTILIZE THESE PRODUCTS. CONTACT YOUR LOCAL REPRESENTATIVE.

Warranty

Humboldt Mfg. Co. warrants its products to be free from defects in material or workmanship. The exclusive remedy for this warranty is Humboldt Mfg. Co., factory replacement of any part or parts of such product, for the warranty of this product please refer to Humboldt Mfg. Co. catalog on Terms and Conditions of Sale. The purchaser is responsible for the transportation charges. Humboldt Mfg. Co. shall not be responsible under this warranty if the goods have been improperly maintained, installed, operated or the goods have been altered or modified so as to adversely affect the operation, use performance or durability or so as to change their intended use. The Humboldt Mfg. Co. liability under the warranty contained in this clause is limited to the repair or replacement of defective goods and making good, defective workmanship.

Humboldt Mfg. Co.
875 Tollgate Road
Elgin, Illinois 60123 U.S.A.

U.S.A. Toll Free: 1.800.544.7220
Voice: 1.708.468.6300
Fax: 1.708.456.0137
E-mail: hmc@humboldtmfg.com

