

09.24

HM-5480.3F

Conmatic IMC Soil Consolidation System

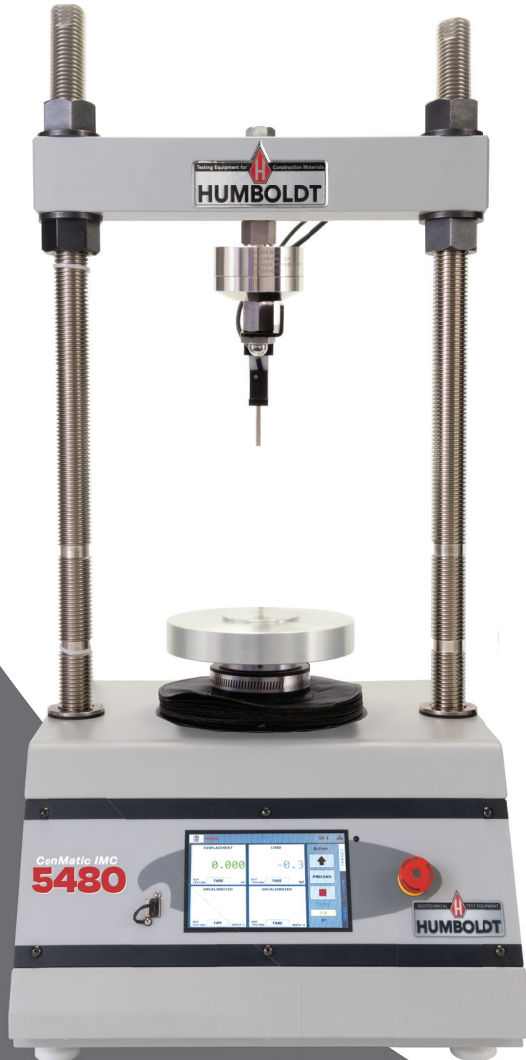

CONTENTS

Quick Start Guide	4	Initial Set Up — Contact	18
Unpacking	4	Contact Information	18
Installation and Equipment Setup	4	Initial Set Up — Update	19
Electrical Connections	4	Update from USB	20
Power Switch	4		
Instrumentation Connections and Setup	5	Equipment Setup	22
Network	5	Installation and Equipment Setup	23
USB Power	5	Electrical Connections	23
Instrument Inputs	5	Power Switch	23
Initial Machine Set-up	6	Instrumentation Connections and Setup	24
Initial Set-up — Calibration	8	Rear Instrumentation Panel	24
Calibration Input Screen	8	Network	24
Units	9	USB Power	24
Value	9	Instrument Inputs	24
Export Calibration via USB	10	Test Deck Setup	25
Import Calibration via USB	10	Screen Feature Descriptions	26
Delete Calibrations	10	Consolidation Cells	28
Restore Factory Calibrations	10	Consolidation Cell Components - Inches	30
		Consolidation Cell Components - Metric	31
Initial Set Up — Date/Time	11	Calibration of Instrumentation	32
Initial Set-up — Preferences	12	How to Perform a Calibration	32
Preferences – General Tab	12	Export Calibration via USB	32
Logger ID	12		
Sound	13	Test Setup	39
Preferences – System Units Tab	13	Consolidation Test Setup	40
Ambient Temperature	13	Test Setup Wizard – Select Test Type	40
Stress Control Unit	13	Test Setup Wizard – Sensor Input Selection	41
Preferences – Specimen Parameters Tab	13	Test Setup Wizard – Select Logging Values	43
Specimen Height	14	Test Setup Wizard – Select Stop Parameters	44
Specimen Diameter	14	CRS Test Setup	51
Preferences – Storage Tab	14	Test Setup Wizard – Select Test Type	51
Test Storage Limit	14	Test Setup Wizard – Sensor Input Selection	52
Recycled Tests	14	Test Setup Wizard – Select Logging Values	52
Test Templates	14	Test Setup Wizard – Seating Configuration	53
Save to USB Check Box	14	Test Setup Wizard – Consolidation Config.	54
		Test Setup Wizard – Select Start Parameters	55
Initial Set Up — Network	15	Swell Test Setup	56
Network Settings Screen	16	Test Setup Wizard – Select Test Type	56
DHCP	16	Test Setup Wizard – Sensor Input Selection	57
IP Information	16	Test Setup Wizard – Select Logging Values	57
Local Status	16	Test Setup Wizard – Select Stop Parameters	59
Internet Status	16	Test Setup Wizard – Select Start Parameters	59
Initial Set Up — Information	16		
System Information	17	HM-547-3F Specifications	60
Firmware Version	17	General Warnings	62
IP Information	17		
Local Status	17		
Internet Status	18		
Memory	18		
Factory Screen	18		
Export Log File	18		

Unpacking

Initial inspection should include checking for physical damage during shipping and obvious external damage to the product.

Package contents are defined by your packing list. Each Loader is configured according to customer specifications. In your inspection, make certain that the contents of your shipment match the documentation provided by your packing list.

Place unit on a flat, smooth surface and use leveling feet (supplied) and use a bubble level to ensure that the unit is level side-to-side and back-to-front.

Installation and Equipment Setup

Electrical Connections

The HM-5480 is equipped with an internal digital switching power supply, which allows it to be used with most power configurations throughout the world. The unit is supplied with an IEC electrical cord with a standard 110V plug.

The HM-5480 arrives ready for operation. Attach the supplied IEC electrical cord to the machine and plug into a standard wall receptacle for use in the United States. For locations other than the U.S., replace the supplied electrical cord with an IEC cord that has the correct plug for your application. The supplied cord can also be used by cutting the standard plug from the cord and attaching the correct plug.

Power Switch

The Power Switch is located on the upper right hand corner of the back of the machine, above the electrical cord inlet. The Fuse Compartment is located between the electrical cord inlet and the Power Switch. The HM-5480 uses a 10 amp fuse. To begin operation, attach the supplied electrical cord, plug it in and press the Power Switch.



Fuse Compartment

Fig. 1 Power Switch

Instrumentation Connections and Setup

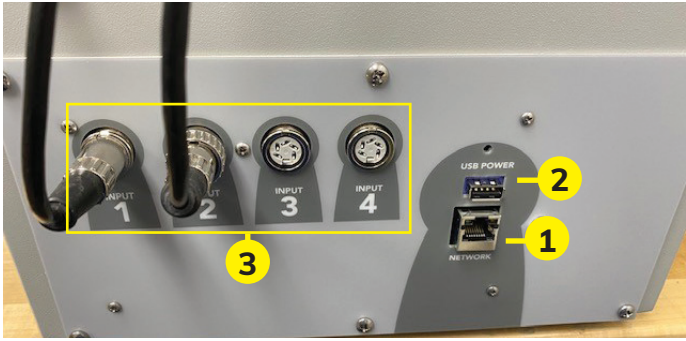

Network (1)

Ethernet input for connecting the machine to a local area network (LAN) and/or the internet.

USB Power (2)

The USB Power port is used for powering a wireless access appliance for those who want to use a wireless LAN setup.

Instrument Inputs (3)

The panel features four (4) inputs for connecting instrumentation to the machine. Each input represents a separate channel and has been assigned and calibrated to a specific instrument for use with your HM-5480 depending on the test type to be performed.

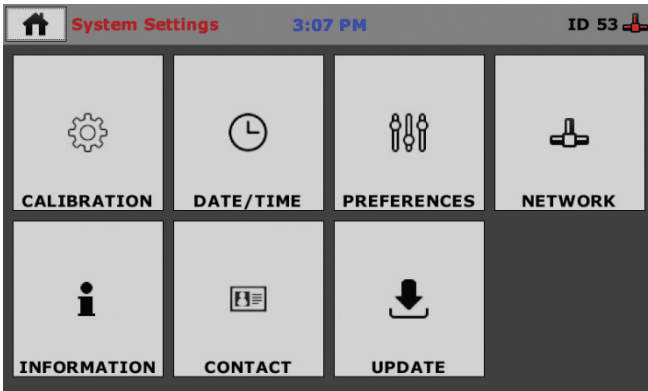

Below are photos of an instrumentation input and its associated plug. Install the plugs into the inputs by lining up the guide at the bottom of the plug with the slot at the bottom of the input.



Instrumentation Input

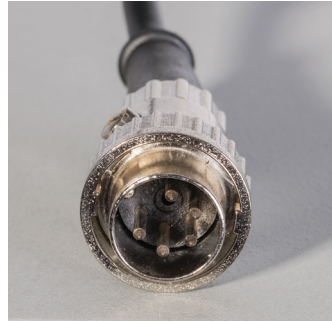

Instrumentation Plug

Once you have installed the instrumentation into the correct inputs, your rear panel should look like this:



Initial Machine Set Up

Remember, your HM-5480 ConMatic IPC, Automated Consolidation Machine includes all the necessary instrumentation, which is already calibrated and assigned to an Input and will not need calibration; however, you should confirm that the instrumentation has been set up and calibrated, that you have plugged them into the correct channel, and that you check with your QC/QA program to set up a frequency of calibration schedule.

DO NOT RECALIBRATE!

When your HM-5480 is first turned on, the screen below will appear.

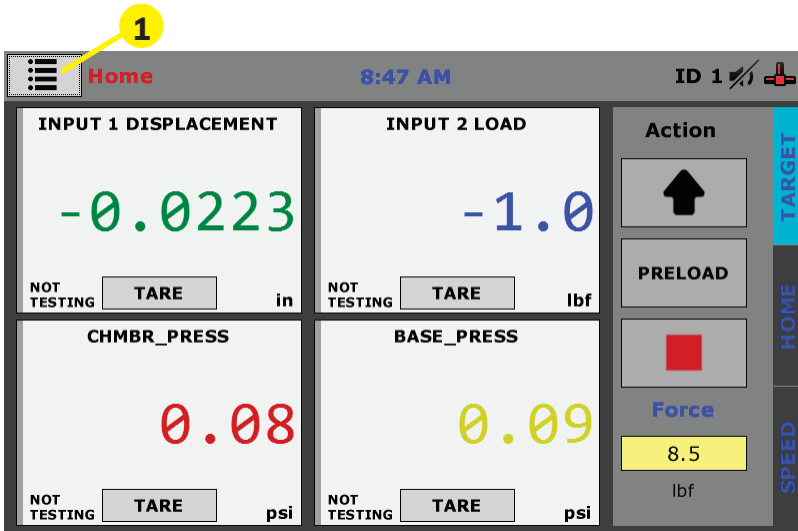

QUICK START GUIDE

From this screen, to confirm your machine instrumentation has been calibrated, navigate to the Calibration section by clicking the Menu icon in the top left corner of the screen (1).

When you click on this button, you will see a drop-down menu appear, see below.

Navigate to the bottom of this drop-down menu and click on System Settings (2). You will see the following screen.

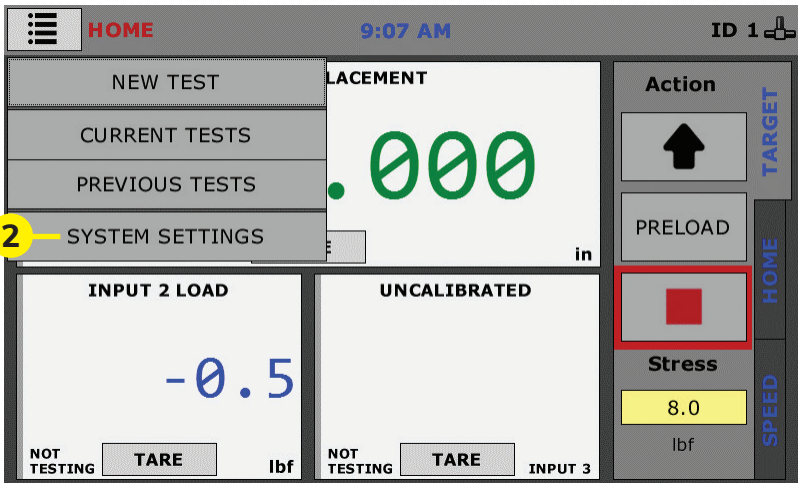

Initial Set Up — Calibration

Click on the Calibration tab in the top left corner **(2)**. You will see the following screen.

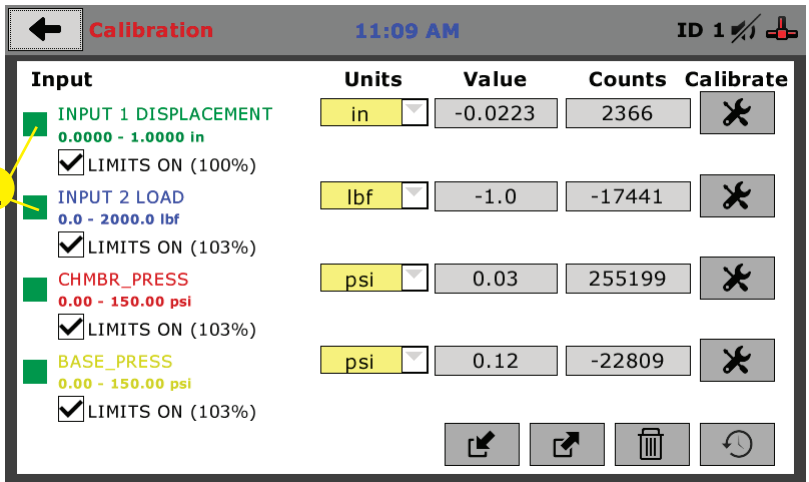
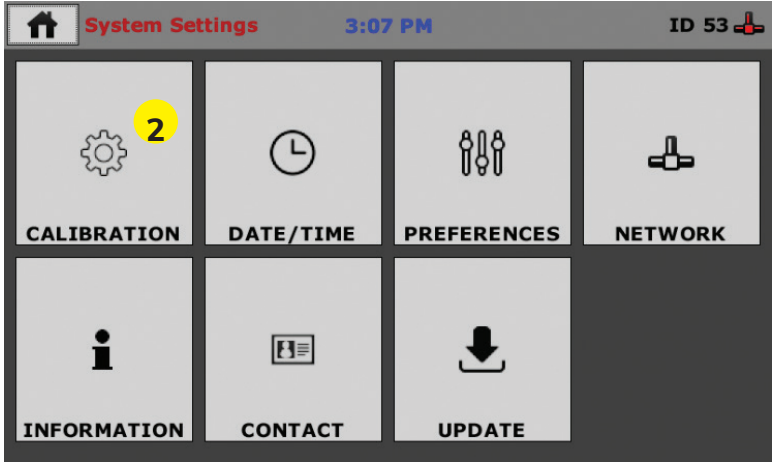

Calibration Input Screen

The Calibration Input Screen (above) is used to monitor and calibrate instrumentation and assign them to specific channels of the HM-5480. The Calibration Input Screen provides a summary of the calibration status of each channel. Please verify that the sensor range and unit of measure are correct.

A green box at the left of a channel indicates that the channel has instrumentation assigned to it and that it is calibrated and ready for use **(1)**.

Calibration Input Screen, cont.

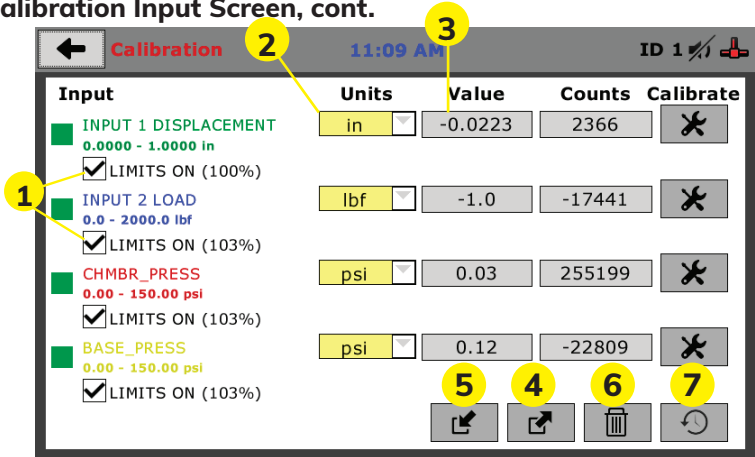

Each channel has a “Limits On” check box (1). It is recommended that this remains checked to ensure the machine cannot exceed the design limits of the instrumentation and damage them. By selecting this option, before the test can exceed the limits of the sensors, all tests will stop running and the motor will stop to avoid damaging connected instrumentation.

Note: An input cannot be calibrated during testing.

Units (2)

In this field, a calibrated instrument will display the units that were chosen for use at the time of calibration. This field can also be used to toggle between English and SI units if the need arises.

Value (3)

This field displays the current calibration value. This value should already be set with 4 decimal point accuracy (1) below. If the instrument is not calibrated, the unit will read “N/A.”

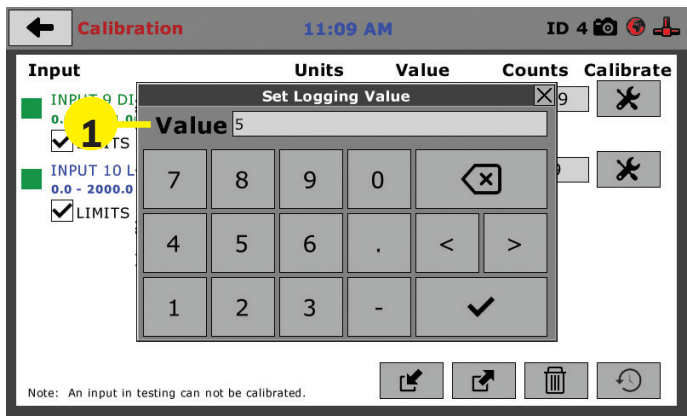

For the HM-5480, Vertical load = 10,000 lbf and vertical displacement = 1.000")

Export Calibration via USB (4)

Press this button to select calibrations to export via USB. It is a good practice to export all your calibrations to a thumb drive. In case of a problem this practice allows you to recover your calibration data quickly.

Import Calibration via USB (5)

Press this button to import calibrations from a USB drive into the HM-5480.

Delete Calibrations (6)

Selecting this button will allow the user to delete any of the desired calibrations from the 5480 memory.

Restore Factory Calibrations (7)

Selecting this button will allow the user to restore the calibrations stored in the permanent memory. This is typically the calibrations set at the factory during final assembly.

Initial Set Up — Date and Time

To set up Date and Time settings, return to the System Settings screen and click on the Date/Time Icon. **(1)**

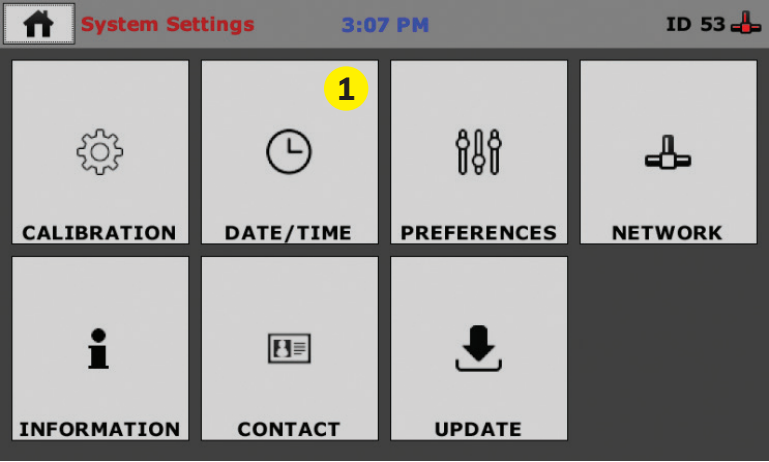

Once the Date/Time icon has been selected the screen shown below will appear.

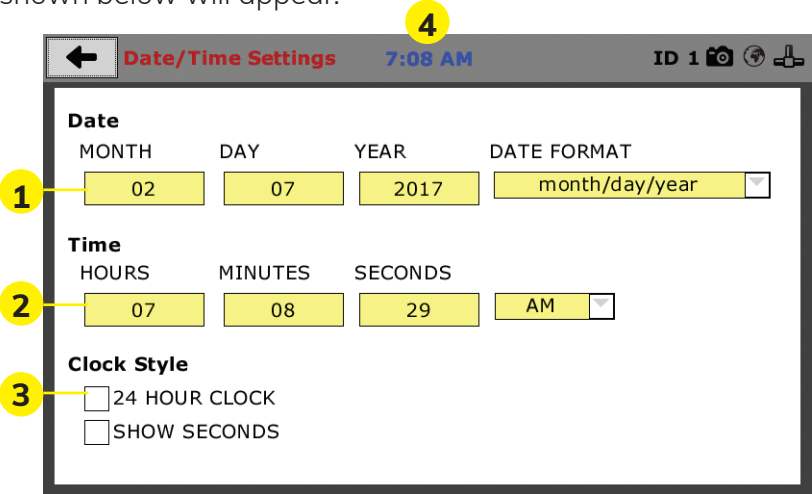

Select any of the yellow boxes in the Date row **(1)** to adjust the date settings.

Select any of the yellow boxes in the Time row **(2)** to adjust the time settings

Select the Clock Style **(3)** to select either a 24 hour or 12 hour time to show on the top of the touch screen.

Initial Set Up — Preferences

This screen is accessed by clicking on the “Preferences” button. **(1)**

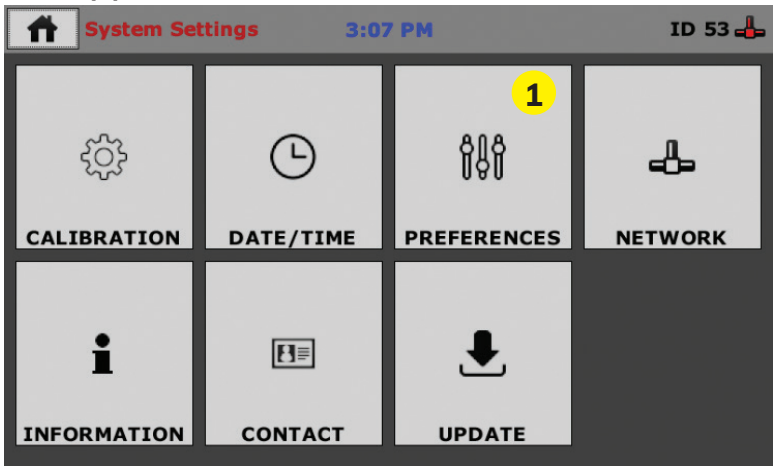

Click on the Preferences tab **(1)**. You will see the following screen.

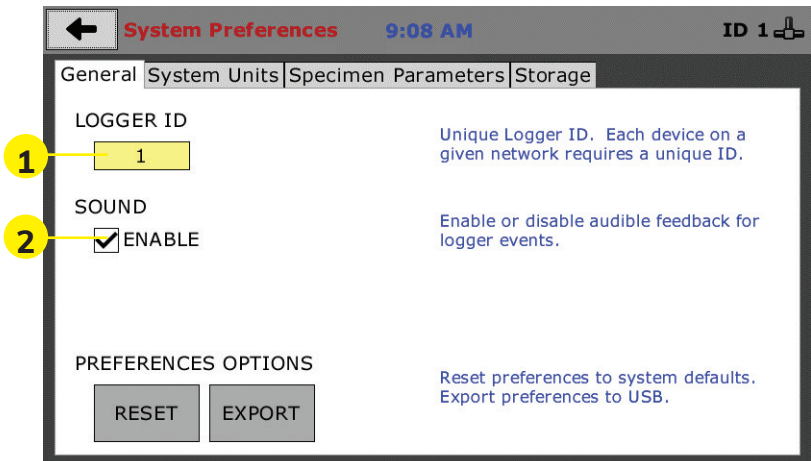

Preferences – General Tab

The Preferences panel is comprised of four (4) tabs and defaults to the General tab, see above.

Logger ID **(1)**

Each machine that is connected to your network requires a unique Logger ID. These numbers can be assigned any number between 1-245. In most cases, if you are setting up a new machine it has been given the Logger ID 1. This would show in the Logger ID field. **(1)**. If this number conflicts with another machine’s Logger ID, one of the machines will have to be changed to another Logger ID.

Sound (2)

Checking this box enables or disables audio feedback for logger events.

Preferences – System Units Tab

This screen is accessed by clicking on the “System Units” Tab under System Preferences.

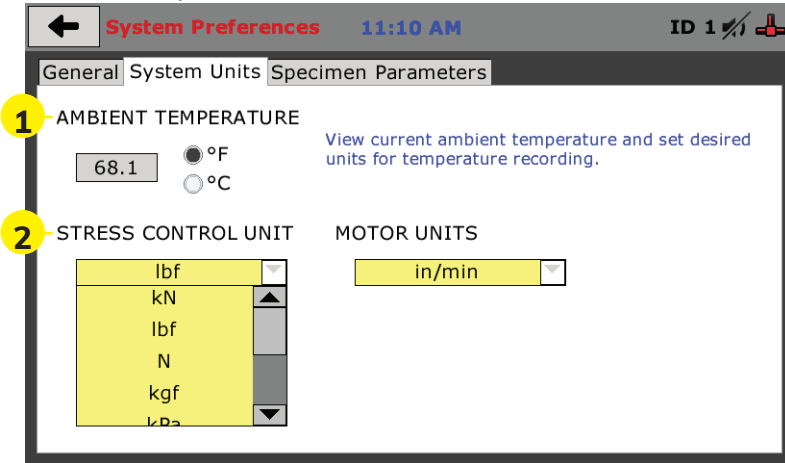

Ambient Temperature (1)

This field displays the current ambient temperature and allows you to select desired units (Fahrenheit or Celsius) for temperature recording.

Stress Control Unit (2)

Click on the desired units you want to use for motor control.

Preferences – Specimen Parameters Tab

This screen is accessed by clicking on the Specimen Parameters Tab under System Preferences.

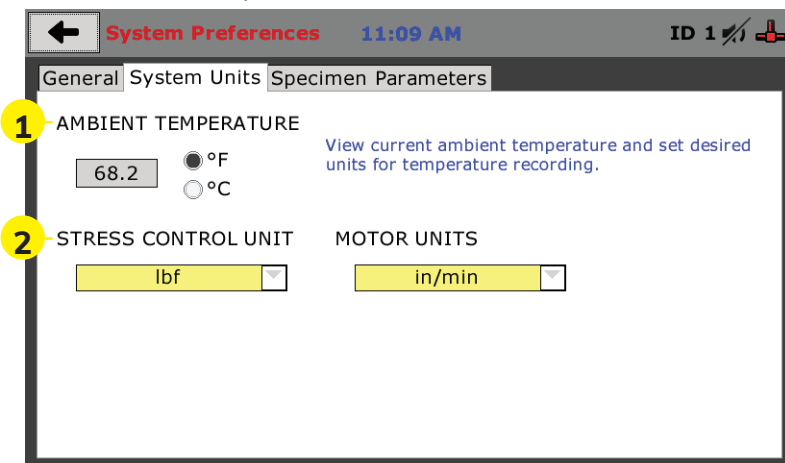

Specimen Height (1)

This field allows you to set the specimen height that will be used for all testing calculations.

Specimen Diameter (2)

This field allows you to set the specimen diameter that will be used for all testing calculations.

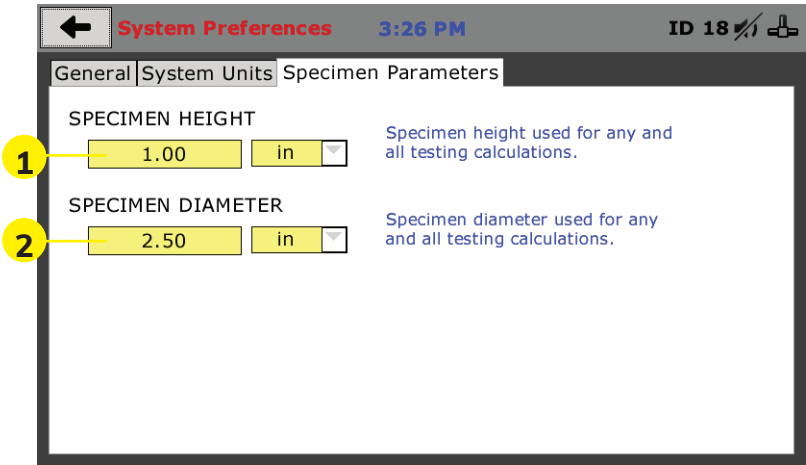

Initial Set Up — Network

To set up Network settings, return to the System Settings screen and click on the Network panel. **(1)**

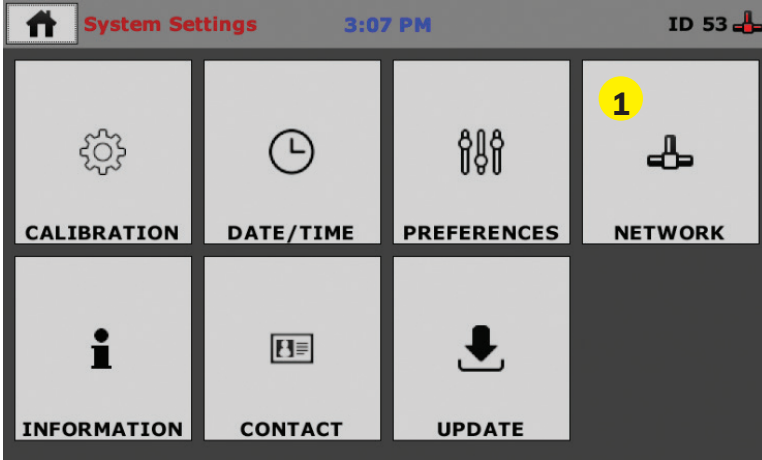

A password is required to access the Network Settings. That password is: **27604**.

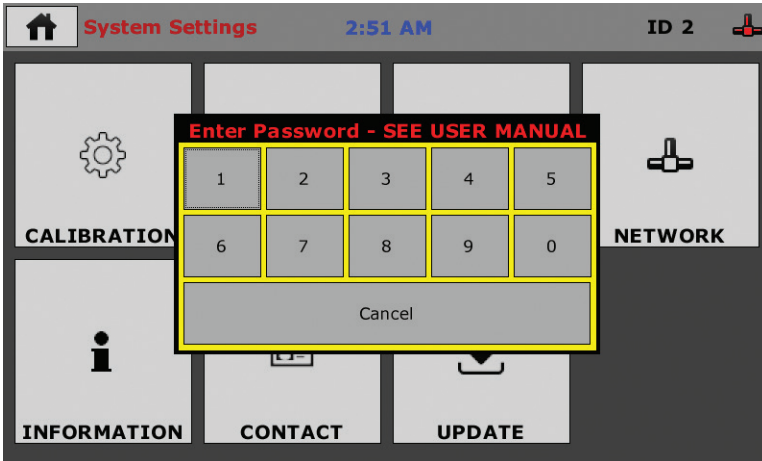

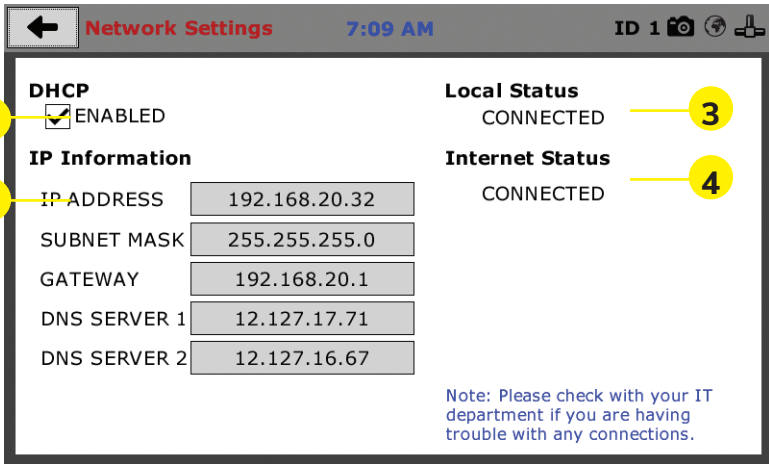

Network Settings Screen

The screen above is the Network Settings screen, it provides information on your IP information and network status.

DHCP (1)

Check this box to enable/disable the Dynamic Host Configuration Protocol (DHCP). If enabled, your machine will pick up IP information from your router. If disabled, you will need to manually enter the network information for a static IP, please consult your network administrator for this.

IP Information (2)

This information will be filled in automatically if the DHCP is checked, otherwise you will have to manually supply this information. The IP address must be unique for each machine.

Local Status (3)

This indicates the status of the local network connection, Connected or Disconnected.

Internet Status (4)

This indicates the status of your Internet connection, Connected or Disconnected.

Note: If you are experiencing issues with any connections, please contact your IT department for assistance.

Initial Set Up — Information

Clicking on this panel provides a view of the current status of the machine. (1)

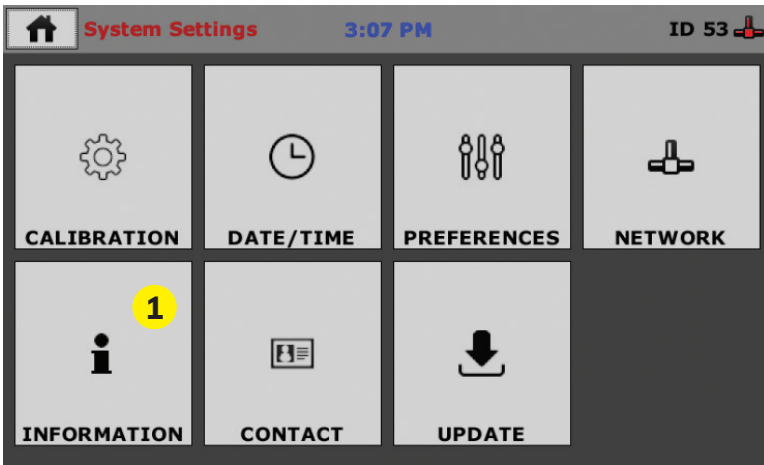

System Information

Below is a view of the System Information screen. It provides a current status of the machine.

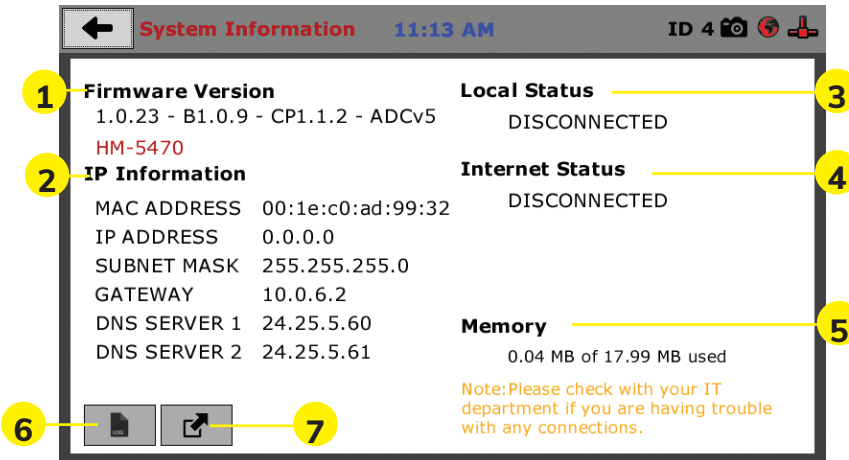

Firmware Version (1)

The current version of the machine firmware is shown here. If you contact product support, you will need to supply this information.

IP Information (2)

This information will be filled in automatically if DHCP is checked, otherwise you will have to manually supply this information. The IP address must be unique for each machine.

Local Status (3)

This indicates the status of the local network connection, Connected or Disconnected.

Internet Status (4)

This indicates the status of your Internet connection, Connected or Disconnected.

Memory (5)

This indicates the current status of how much available memory is being used by the machine

Factory Screen (6)

This is for Humboldt use only.

Export Log File (7)

This button exports a log file from the machine to a USB thumb drive. Be sure to insert a thumb drive before exporting the file or you will receive an error message. This file can be helpful in trouble shooting by Humboldt Support.

Initial Set Up —Contact

Clicking on this panel provides contact information for Humboldt Support and Service(1)

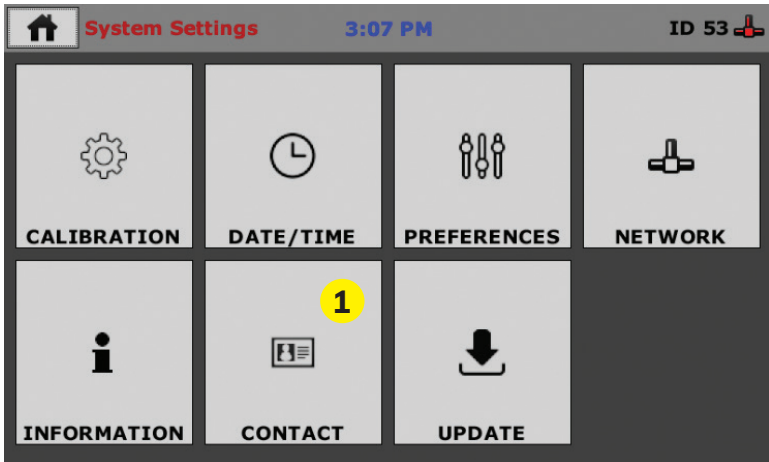

Contact Information

Below is a view of the Contact Information screen showing contact information for Humboldt Support and Service.

For quickest response go to this link on our website:

<https://www.humboldtmfg.com/support> and fill in the support form. This will provide us with the necessary information to assist you and you will be added to the next position in the support cue.

You can also email Humboldt Support at support@humboldtmfg.com or Humboldt Service at service@humboldtmfg.com. Please include contact information and a detailed description of your reason for contact.

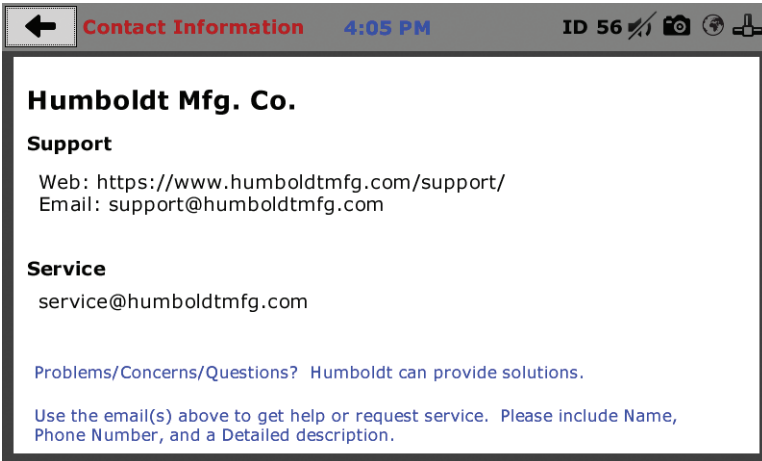

Initial Set Up — Update

Clicking on this panel provides information on checking for Updates, performing updates and an update history for the machine. **(1)**

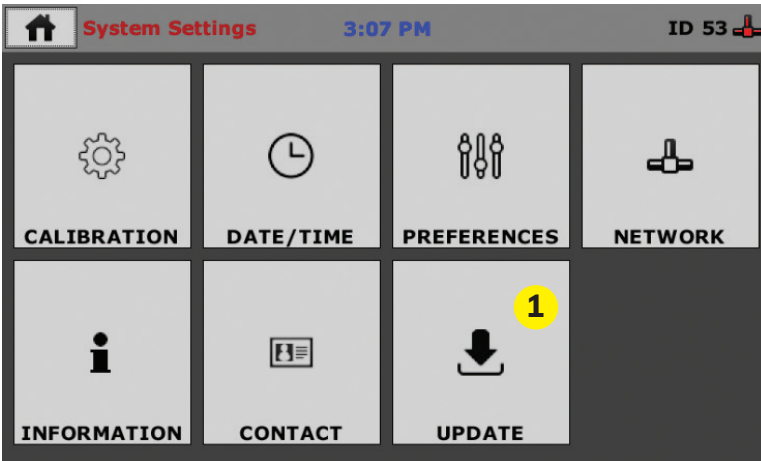

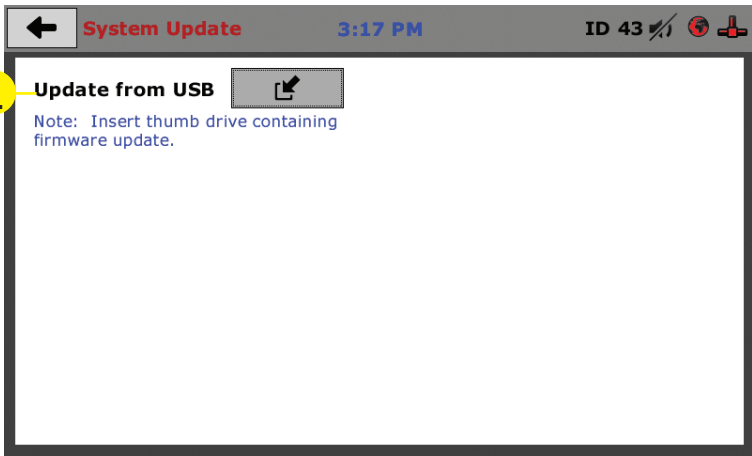

Update from USB (1)

Software updates for your machine can be downloaded from the Humboldt website Support Area using a computer. To access the Software Update area, go to: <https://www.humboldtmfg.com/support/software.php>.

Once on this page, click on the Elite Series Firmware tab. You will see a list of Humboldt Elite Series machines. Click on the HM-5480 Current Version link and the firmware update will begin to download to your computer. Once the download is complete. Load the file onto a USB thumb drive and insert the thumb drive into the USB port on the front of the HM-5480. With the USB thumb drive inserted into the USB port, click on Update from USB **(1)**.

A window will open and you will see a list of Updates. Select a file to use for your update and click the Select button.

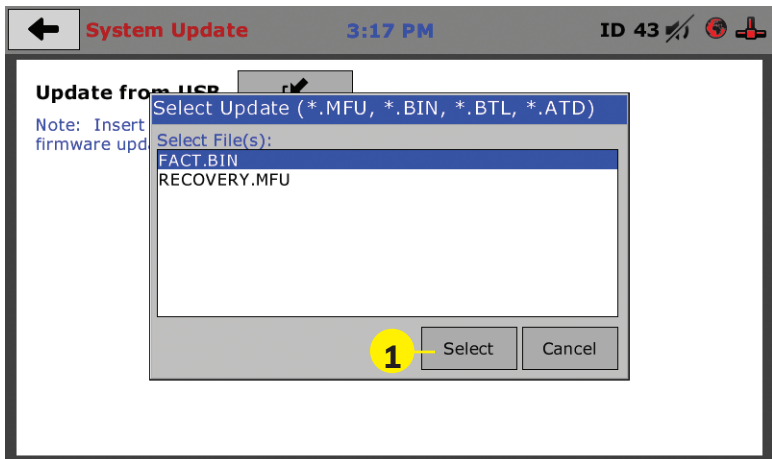

The update process will begin. This may take several minutes. Your HM-5480 may reboot several times during the update, do not turn off or reset machine during this process.

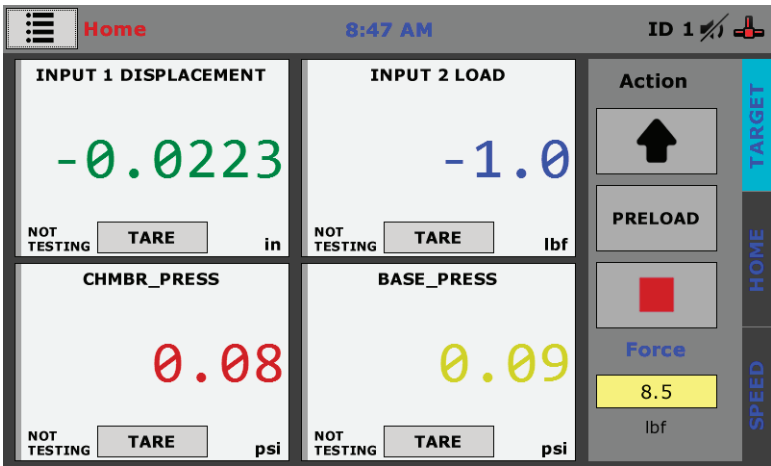

Operation from a Computer and NEXT Software

This manual covers the setup and operation of the HM-5480 ConMatic IMC, Automated Consolidation Machine in Stand-alone Mode only. The HM-5480 is designed to operate independent of NEXT testing software. However, CSV and HTD file formats can be exported from the HM-5480 for use in NEXT or other testing reporting formats.

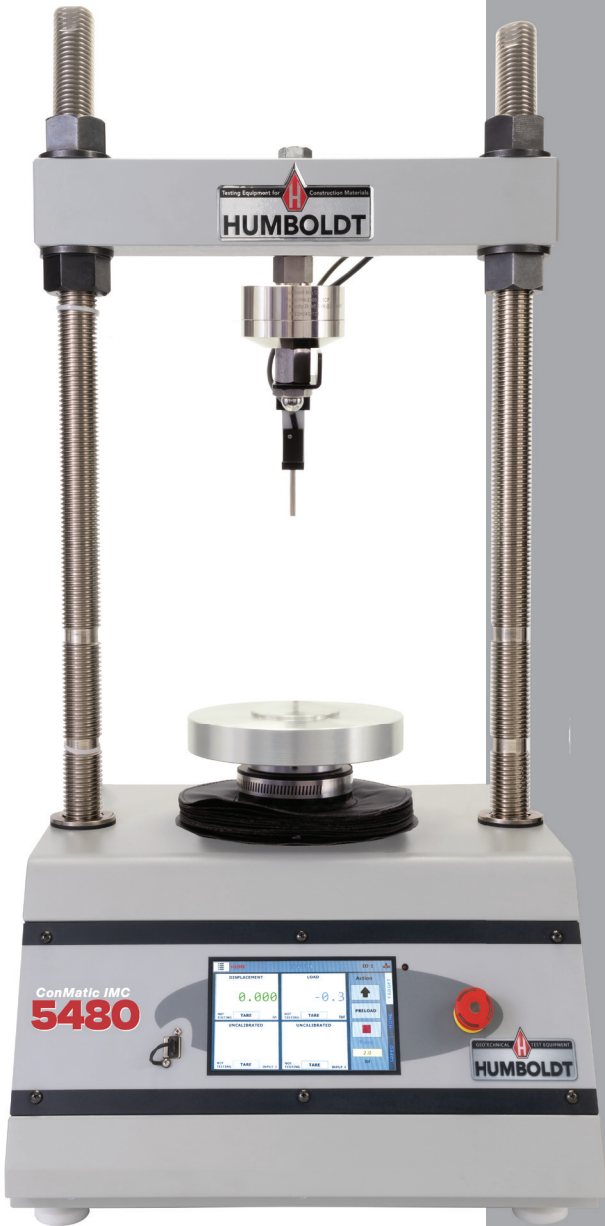

Equipment Setup

Installation and Equipment Setup

Electrical Connections

The HM-5480 is equipped with an internal digital switching power supply, which allows it to be used with most power configurations throughout the world. The unit is supplied with an IEC electrical cord with a standard 110V plug.

The HM-5480 arrives ready for operation. Attach the supplied IEC electrical cord to the machine and plug into a standard wall receptacle for use in the United States. For locations other than the U.S., replace the supplied electrical cord with an IEC cord that has the correct plug for your application. The supplied cord can also be used by cutting the standard plug from the cord and attaching the correct plug.

Power Switch

The Power Switch is located on the upper right-hand corner of the back of the machine, above the electrical cord inlet. The Fuse Compartment is located between the electrical cord inlet and the Power Switch. The HM-5480 uses a 10-amp fuse. To begin operation, attach the supplied electrical cord, plug it in and press the Power Switch.



Fuse Compartment

Power Switch

Instrumentation Connections and Setup

HM-5480 Rear Instrumentation Panel

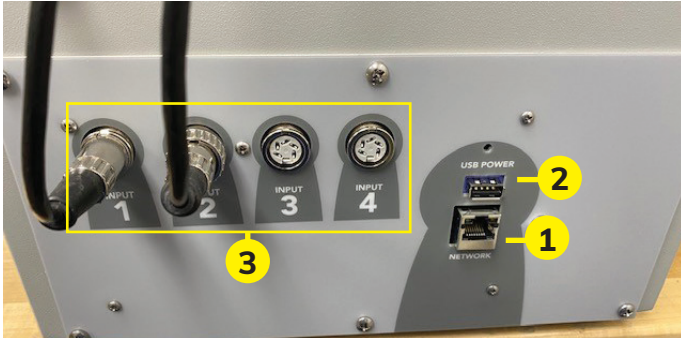

Above is a photo of the rear instrumentation panel of the HM-5480.

Network (1)

Ethernet input for connecting machine to a local area network and/or the internet.

USB Power (2)

The USB Power port is used for powering a wireless receiver/transmitter for those who want to use a wireless LAN setup.

Instrument Inputs (3)

The panel features four (4) input channels for connecting instrumentation to the machine. Each input represents a separate channel and has been assigned and calibrated to a specific instrument for use with your HM-5480.

Below are photos of an instrumentation input and the instrumentation plug. The instrumentation plugs are numbered and should be installed in the corresponding numbered input. Install the plugs into the inputs by lining up the guide at the bottom of the plug with the slot at the bottom of the input channel. Disregard the locking collar on the plugs as they are not required for this device.



Once you have installed the instrumentation into the correct inputs, your rear panel should look like this:



Test Deck Setup

Below is how your HM-5480 should be set up for operation. When you receive your unit, your instrumentation should already be mounted in place. It has been tied down with plastic ties for shipping so you should remove these ties before operation. You may have to make small position adjustments to the instrumentation for optimal operation.

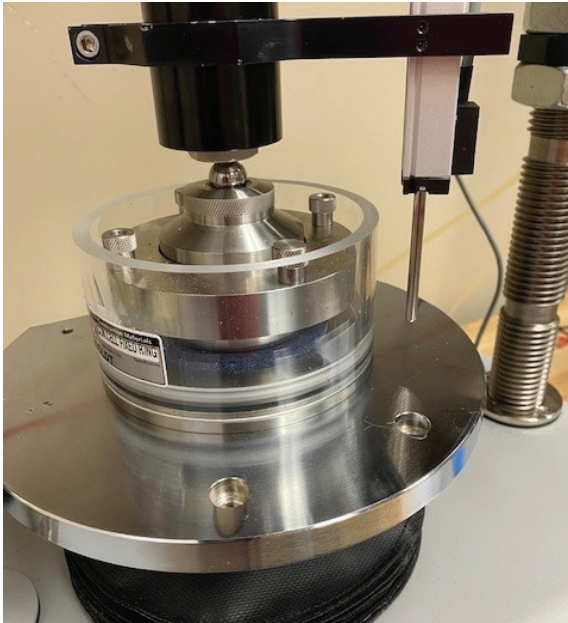

Screen Feature Descriptions

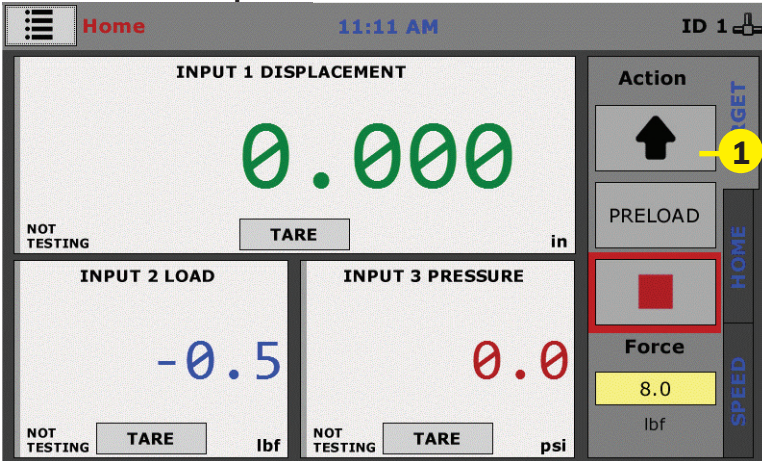

Target Tab

1. Up: Will cause the platen to move up. Will retreat motor to full lower travel.

Preload: Selecting this button will move the platen to the designated preload that has been determined in the Test Setup window.

Stop: Will release all load on the sample, and retract to the lowest position of platen.

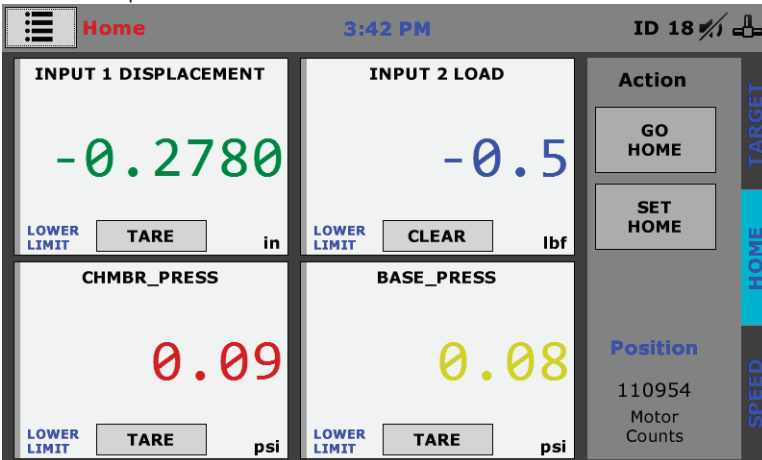

Go Home: Selecting this button will move the platen back to the user defined origin. (This is noted when the position is zero motor)

Set Home: This sets the origin (home position) for the motor. Commonly this will be set to allow the consolidation cell to be loaded or unloaded from the platen between tests. When at home position the motor counts will be zero.

Find Home: Will locate user defined home position.

Position: Indicates the motor position. Home is always indicated as

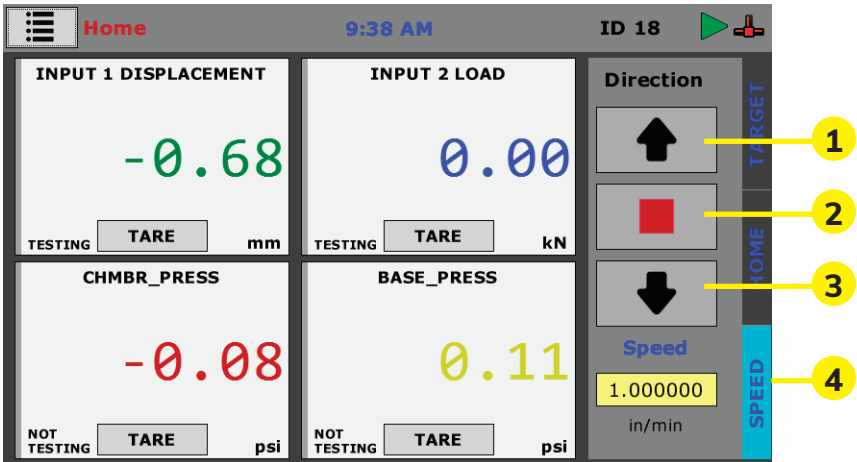

(1) Up: Will move the platen up at the rate indicated in the speed box.

NOTE: Pressing and holding either the up or down arrow button will cause the platen to move in high-speed mode (2.000"/minute).

(2) Stop: Will stop all platen movement

(3) Down: Will move the platen down at the rate indicated in the speed box.

(4) Speed: By selecting this window the user can define the rate of travel for the platen when the up or down buttons are pushed. Note: this application does not apply to when a test is running.

Consolidation Cells

Fixed Ring Consolidation Cell

ASTM: D2435, D4546, AASHTO: T216,
BS:1377:5

Complete cell assembly features stainless steel construction and self-trimming cutter ring. Cutter ring rests inside clamping ring on lower porous stone, which is larger than the sample. The top porous stone and loading pad rest on the sample. The assembly is fixed on the cell base and enclosed within an acrylic cylinder open to the atmosphere, which permits saturation of the sample. The cell comes complete with all the parts illustrated in the drawing below.



Floating Ring Consolidation Cell

ASTM: D2435, D4546, AASHTO: T216,
BS:1377:5

Complete cell assembly features stainless steel construction with self-trimming cutter ring. Similar in construction to a fixed ring cell with the exception that the lower porous stone fits inside the cutter ring and can move vertically within it. The sample ring is also free to move vertically. The cell comes complete with all the parts illustrated in the drawing below.



Fixed Ring Consolidation Cell			
2.0"	HM-1220.20	50mm	HM-1220.50
2.42"	HM-1220.242	70mm	HM-1220.70
2.5"	HM-1220.25	75mm	HM-1220.75
3.0"	HM-1220.30	100mm	HM-1220.100
4.0"	HM-1220.40		

Floating Ring Consolidation Cell			
2.0"	HM-1210.20	50mm	HM-1210.50
2.42"	HM-1210.242	70mm	HM-1210.70
2.5"	HM-1210.25	75mm	HM-1210.75
3.0"	HM-1210.30	100mm	HM-1210.100
4.0"	HM-1210.40		

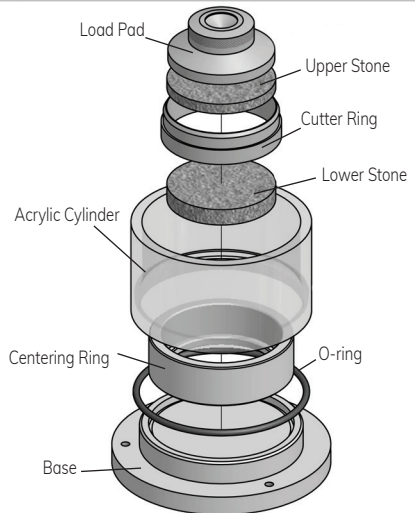
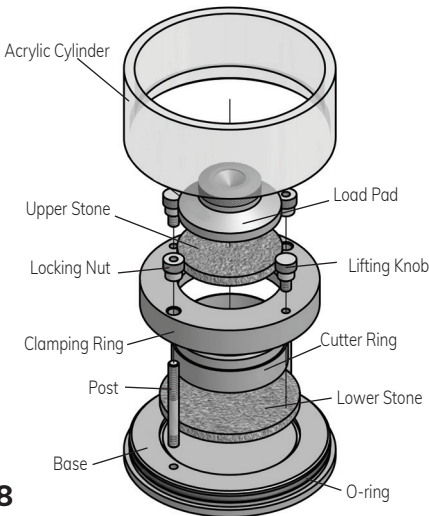

Fixed Ring Permeability Cell

ASTM: D2435, D4546, AASHTO: T216,
BS:1377:5

Similar in construction to a fixed ring cell with the exception that the saturated sample and water are sealed from the atmosphere. Complete cell assembly features stainless steel construction and self-trimming cutter ring. Base features outlet port and 10cc pipette for monitoring water level. The cell comes complete with all the parts illustrated in the drawing below, as well as a pipette.

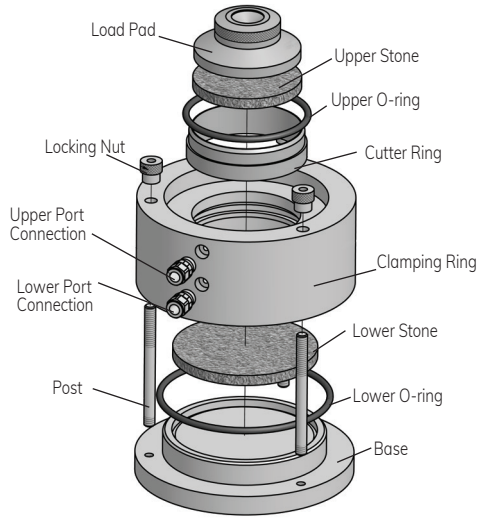

Fixed Ring Permeability Cell			
2.0"	HM-1230.20	50mm	HM-1230.50
2.42"	HM-1230.242	70mm	HM-1230.70
2.5"	HM-1230.25	75mm	HM-1230.75
3.0"	HM-1230.30	100mm	HM-1230.100
4.0"	HM-1230.40		

Consolidation Cell Components – inches

Consolidation Cell Components					
	20"	242"	25"	30"	40"
Load pad	HM-1220.20.10	HM-1220.24.10	HM-1220.25.10	HM-1220.30.10	HM-1220.40.10
Upper stone	HM-4184.1985	HM-4184.240	HM-1220.25.11* HM-4184.2485	HM-4184.2985	HM-4184.3985
Lower stone (floating)	HM-4184.1985	HM-4184.240	HM-4184.2485	HM-4184.2985	HM-4184.3985
Lower stone (fixed & permeability)	HM-4184.331	HM-4184.331	HM-4184.331	HM-4184.331	HM-4184.4375T
Acrylic cylinder (fixed)	HM-1220.25.2	HM-1220.25.2	HM-1220.25.2	HM-1220.25.2	HM-1220.40.2
Acrylic cylinder (floating)	HM-1210.25.2	HM-1210.25.2	HM-1210.25.2	HM-1210.25.2	HM-1210.40.2
Centering ring (floating)	HM-1210.20.12	HM-1210.24.12	HM-1210.25.12	HM-1210.30.12	HM-1210.40.12
Clamping ring (permeability)	HM-1230.20.9	HM-1230.24.9	HM-1230.25.9	HM-1230.30.9	HM-1230.40.9
Clamping ring (fixed)	HM-1220.20.9	HM-1220.24.9	HM-1220.25.9	HM-1220.30.9	HM-1220.40.9
Base (floating & permeability)	HM-1230.25.1	HM-1230.25.1	HM-1230.25.1	HM-1230.25.1	HM-1230.40.1
Base (fixed)	HM-1220.25.1	HM-1220.25.1	HM-1220.25.1	HM-1220.25.1	HM-1220.40.1
Cutter ring (all)	HM-1220.20.8	HM-1220.24.8	HM-1220.25.8	HM-1220.30.8	HM-1220.40.8
Lower o-ring (floating & permeability)	HM-003053	HM-003053	HM-003053	HM-003053	HM-003056
Lower o-ring (fixed)	HM-003052	HM-003052	HM-003052	HM-003052	HM-003024
Upper o-ring (permeability)	HM-003057	HM-003058	HM-003054	HM-003059	HM-003060
Post (all)	HM-1220.25.3	HM-1220.25.3	HM-1220.25.3	HM-1220.25.3	HM-1220.25.3
Locking nut (all)	HM-1220.25.5	HM-1220.25.5	HM-1220.25.5	HM-1220.25.5	HM-1220.25.5
Lifting knob (all)	HM-1220.25.6	HM-1220.25.6	HM-1220.25.6	HM-1220.25.6	HM-1220.25.6
Port connection upper (permeability)	HM-003027	HM-003027	HM-003027	HM-003027	HM-003027
Port connection lower (permeability)	HM-003055	HM-003055	HM-003055	HM-003055	HM-003055
Filter paper	HM-4189.20	HM-4189.25	HM-4189.25	HM-4189.30	HM-4189.40
Calibration disk (used for consolidation or round shear box.)	HM-1220.20.4	HM-1220.24.4	HM-1220.25.4	HM-1220.30.4	HM-1220.40.4

Consolidation Cell Components – metric

Consolidation Cell Components				
	50mm	70mm	75mm	100mm
Load pad	HM-1220.50.10	HM-1220.70.10	HM-1220.75.10	HM-1220.100.10
Upper stone	HM-4184.1955	HM-4184.274	HM-4184.2940	HM-4184.3925
Lower stone (floating)	HM-4184.1955	HM-4184.274	HM-4184.2940	HM-4184.3925
Lower stone (fixed & permeability)	HM-4184.331	HM-4184.331	HM-4184.331	HM-4184.4375T
Acrylic cylinder (fixed)	HM-1220.25.2	HM-1220.25.2	HM-1220.25.2	HM-1220.40.2
Acrylic cylinder (floating)	HM-1210.25.2	HM-1210.25.2	HM-1210.25.2	HM-1210.40.2
Centering ring (floating)	HM-1210.50.12	HM-1210.70.12	HM-1210.75.12	HM-1210.100.12
Clamping ring (permeability)	HM-1230.50.9	HM-1230.70.9	HM-1230.75.9	HM-1230.100.9
Clamping ring (fixed)	HM-1220.50.9	HM-1220.70.9	HM-1220.75.9	HM-1220.100.9
Base (floating & permeability)	HM-1230.25.1	HM-1230.25.1	HM-1230.25.1	HM-1230.40.1
Base (fixed)	HM-1220.25.1	HM-1220.25.1	HM-1220.25.1	HM-1220.40.1
Cutter ring (all)	HM-1220.50.8	HM-1220.70.8	HM-1220.75.8	HM-1220.100.8
Lower o-ring (floating & permeability)	HM-003053	HM-003053	HM-003053	HM-003056
Lower o-ring (fixed)	HM-003052	HM-003052	HM-003052	HM-003024
Upper o-ring (permeability)	HM-003057	HM-003061	HM-003062	HM-003063
Post (all)	HM-1220.25.3	HM-1220.25.3	HM-1220.25.3	HM-1220.25.3
Locking nut (all)	HM-1220.25.5	HM-1220.25.5	HM-1220.25.5	HM-1220.25.5
Lifting knob (all)	HM-1220.25.6	HM-1220.25.6	HM-1220.25.6	HM-1220.25.6
Port connection upper (permeability)	HM-003027	HM-003027	HM-003027	HM-003027
Port connection lower (permeability)	HM-003055	HM-003055	HM-003055	HM-003055
Filter paper	HM-4189.20	HM-4189.28	HM-4189.30	HM-4189.40
Calibration disk (used for consolidation or round shear box.)	HM-1220.50.4	HM-1220.70.4	HM-1220.75.4	HM-1220.100.4

Calibration of Instrumentation

The HM-5480.3F ConMatic IMC Automated Consolidation Machine includes all necessary instrumentation. All instrumentation included with this unit has been calibrated and assigned to specific channels for use. These channels are marked on the corresponding instrumentation and the correct calibration information will appear in the channel calibration parameters, once you have installed the instrumentation to the correct inputs.

DO NOT RECALIBRATE!

How to Perform a Calibration

All instrumentation included with this unit has been calibrated and assigned to specific channels for use. Humboldt recommends (and standard lab practice dictates) that your HM-5480 should be calibrated periodically. For most, recalibration is conducted annually, though other rules may apply to the frequency of calibration.

To perform a calibration, it will be necessary to either hire a calibration service to come in and calibrate your machine, or have the necessary calibration equipment to perform this service.

To begin a calibration, it is always a good idea to save the current calibration settings. If you have already saved these settings to a USB thumb drive or your computer, this step can be skipped

Export Calibration via USB (4)

Press this button to select calibrations to export via USB. It is a good practice to export all your calibrations to a thumb drive. In case of a problem this practice allows you to recover your calibration data quickly (See pages 9-10 in Quick Start).

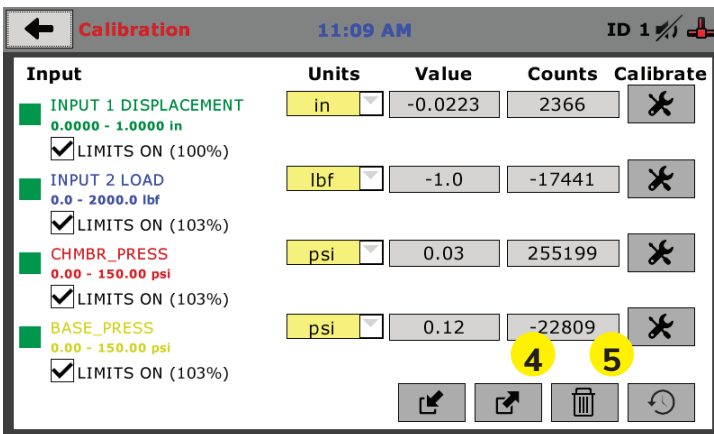

Once your calibrations have been saved, click on the trash can icon (5) to begin to erase both (2) Input calibrations. When you press the trash can icon, this screen will appear.

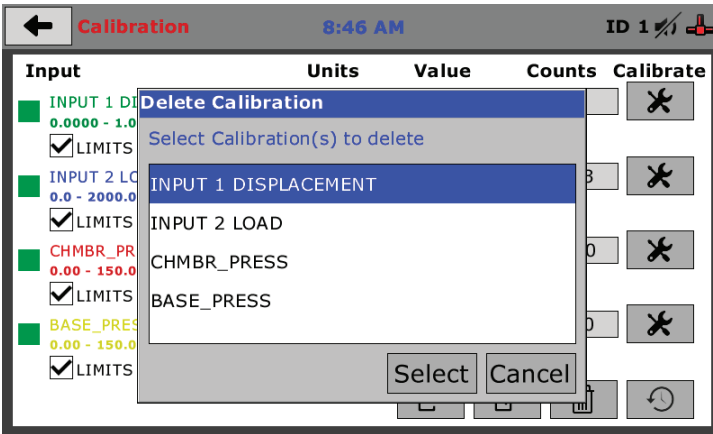

On this screen select an Input calibration to delete, one at a time, and then press the Select button. The channel will be deleted. This is typical for any channel to be deleted.

Once all Input calibrations have been cleared, your Calibration window should look like the one below with no Inputs calibrated.

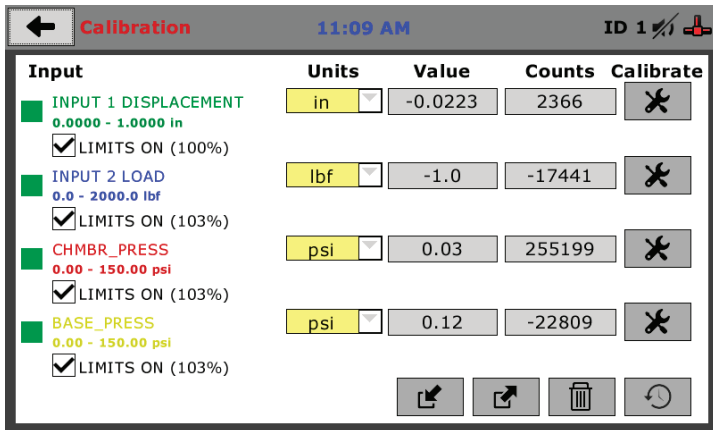

By default the system will determine which channel is load or displacement based on the calibrations loaded into the system. It will typically default to Channel 1 being displacement and Channel 2 being load. It is recommended that these settings be maintained if the test data is to be exported to NEXT or Data Download for reporting purposes.

Calibrating your instrumentation to the appropriate Input requires a separate device, which can provide precise and specific loads or displacement, and, which has been certified to be accurate. The calibration process involves plugging the instrumentation into the HM-5480 while placing the instrumentation into the certified calibration device, which provides a specific set load or displacement.

Once this has been done, click the Calibrate button next to the appropriate Input **(1)**.

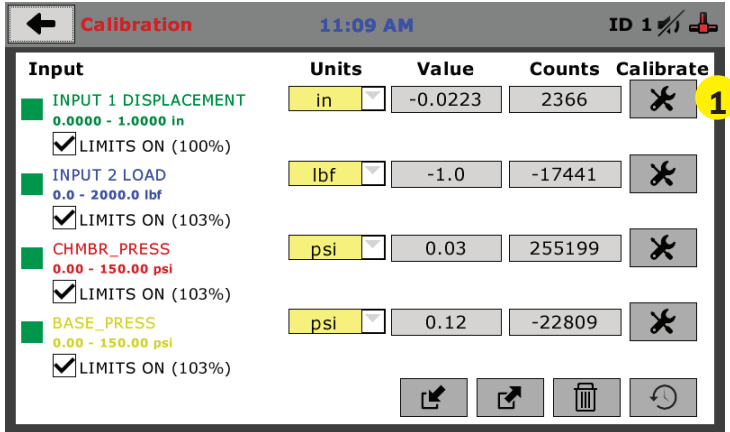

A pop-up window will appear requiring you to enter the password, which is **22234**.

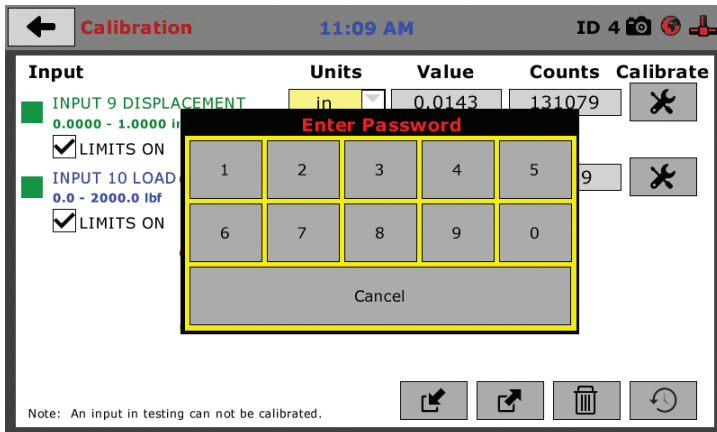

Upon filling in the password, you will see this screen, Tab 1 Sensor Details of the Calibration settings.

On Tab 1, the Sensor Type **(1)** will default to Displacement Load. For Capacity **(2)**, fill in the maximum capacity of the sensor and choose either lbf or kN. For FS output **(3)**, refer to the calibration sheet, which came with the instrument your are using and enter it here and then choose mV/V. Below are typical calibration sheets with the FS Output information highlighted in orange.



Humboldt Calibration Certificate

Model	HM-2300.020
Full scale Output	3,000.0mV/V
NTEP#	06-080
Serial#	216907
Capacity	2,000 lb
Date	01/20/2017

Zero Balance	1.00% FS
Rated Excitation	10 Vdc
Compensated Temp. Range	14 to 104 °F (-10°C to 40°C)
Insulation Res.	>1,000 Megohms at 50V DC
Barometric Effect	Nil
Input Resistance	385± 15Ω
Output Resistance	350± 3Ω
Minimum Dead Load	40LB
Vmm	0.060LB
Safe overload (150%)	150% of capacity
Ultimate Overload (300%)	150% of capacity

Wiring Code			
Red	+ Excitation	Black	- Excitation
Green	+ Output	White	- Output

Caution: Cutting cable will affect the Full Scale Output calibration and Voids warranty!

Data obtained utilizing standards traceable to the National Institute of Standards & Technology.

Humboldt Mfg. Co.

Test Report & Data

Linear Displacement Sensor 3500 Full Bridge balance output

Model **HM-2310.10** Serial No **15869**

Test Results			
Test Volts	5.00	Volts Sensitivity @ 25mm	6.880 mV/V
Displacement	25.69 mm	Non Linearity	0.04% Full Scale
Test data is based on best fit line (worst case for error)			
Input volts		2-10 AC or DC	
Wiring Connections			
Excitation +	Red	1	Signal + Green
Excitation -	Blue	2	Signal - Yellow
Pin No. - Only when factory fitted with DIN plug			
Operational Notes			
1 The outer case must not be distorted when clamping the sensor, a full diameter clamp is strongly recommended.			
2 The sensor is not recommended for use in hostile or extreme environments without protection.			
3 Special tools are required to remove the plunger tip (anvil). This Anvil forms the mechanical stop for the extent of the plunger travel and must only be removed under controlled conditions that prevent the spindle being depressed into the body of the sensor.			
Notes			
<p>Humboldt Mfg. Co</p> <p>875 Tollgate Road, Elgin, IL 60123, USA</p> <p>Fax: +1708-456-0137, Email: hmc@humboldtmgf.com Web: www.humboldtmgf.com</p>			

C:\Users\hmc\Desktop\Senior Test\Report\Products\2017\15869.05-1

Once this is complete, click on the Right Arrow in the bottom right-hand corner of the screen to save these settings. You will be taken to Tab 2, Limits.

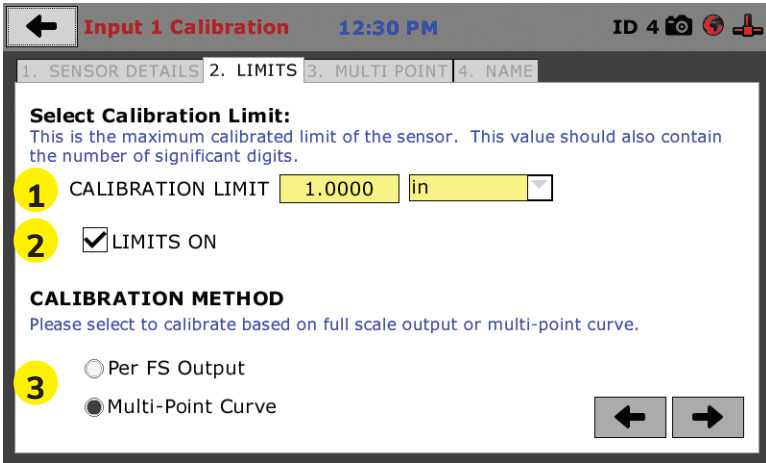

On Tab 2, in the Calibration Limit field **(1)**, enter the maximum calibrated limit of the sensor. This value should contain the number of decimal points required for accuracy as per ASTM standards up to a maximum of 5 points. Limits On **(2)**, should be checked if you don't want the machine to apply a load greater than the Calibration Limit **(1)**. Calibration Method **(3)** determines whether this calibration will be based only on the maximum load capacity of the sensor or upon a multi-point curve of up to a maximum of 10 points.

If you choose Per FS Output (not a recommended calibration method) it will base your calibration on the maximum load capacity of the sensor vs. zero load capacity of the sensor. If you choose this method and click on the Right Arrow in the bottom right-hand corner of the screen. You will be prompted to remove any load on the sensor and click on Done **(4)** when you have done so.

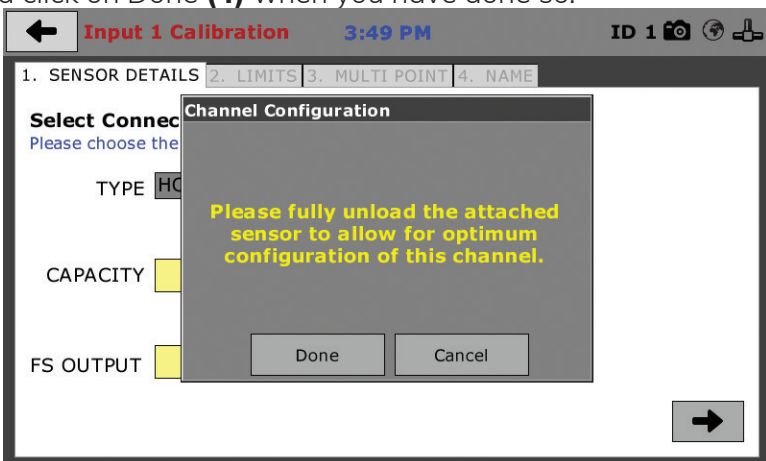

If you choose Multi-Point (Recommended calibration method) Curve and click on the Right Arrow in the bottom right-hand corner of the screen, you will be taken to Tab 3.

Input 1 Calibration 12:31 PM ID 4

1. SENSOR DETAILS 2. LIMITS 3. MULTI POINT 4. NAME

Create Multi-Point Calibration:
Please note a minimum of 2 points are required for a successful calibration.

POINT	APPLIED	A/D COUNTS
0	0.0000	-38184
1	0.2000	2322196
2	0.4000	4686872
3	0.6000	7050367
4	0.8000	9413383
5	1.0000	11768198
6		
7		
8		
9		
10		

Entry Method
 QUICK CLICK
 MANUAL ENTRY

Calibration
 5 Point

Clear All Points

← →

On Tab 3 you will be able to set the number of points you want to use for your calibration. You can choose 1-point, 5-point, 10-point or Custom, which allows you to use any number of points up to a total of 10. In the example on the previous screen shot above, a 5-point calibration has been chosen.

With your instrumentation sensor placed in a calibration frame and the sensor plugged into the Input on the HM-5480. You will set the “0” point at 0 with no load applied to the sensor. The “5” point will be set with the maximum load capacity of the sensor applied. Points “1” through “4” are usually determined by spacing them out evenly between the no load reading and the maximum load reading. As an example, if you have a sensor with a 1,000 lb maximum force capability, you would set the “0” point at “0” and the “5” point at 1,000. Points “1” through “4” would typically be set at: “1” 200; “2” 400; “3” 600; “4” 800 and “5” 1000. Or, divide the maximum load number by the number of points, in this case 5, which works out to 200 point increments between points. See below.

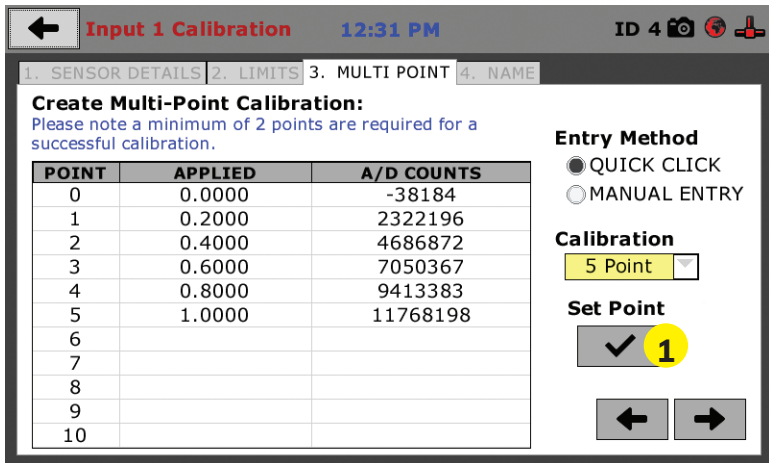

Each point would be chosen by clicking on the corresponding point row above. The load would be applied to the sensor and an A/D Counts reading would appear. To set the point, click on the Set Point button **(1)**. This would be repeated until all points have been set. In the example above, Point 3 is being calibrated and is ready to have the Set Point button **(1)** clicked. Point 4 still needs to be calibrated.

Once all Points have been calibrated, click on the Right Arrow in the bottom right-hand corner of the screen. You will be taken to Tab 4.

On Tab 4, you will be asked to name the calibrated Input.

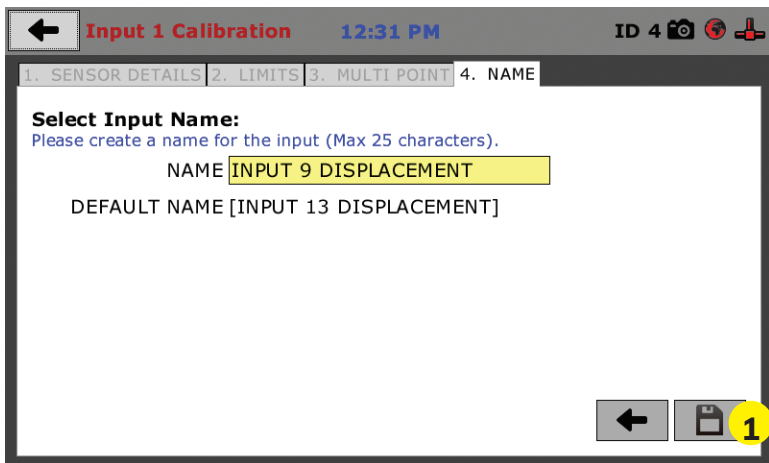

The screen will provide a default name, but you can name the Input anything you'd like. Once you've named the Input, click on the disk icon in the lower, right-hand corner **(1)**. This will save it. Use this method for calibrating any additional Inputs necessary.

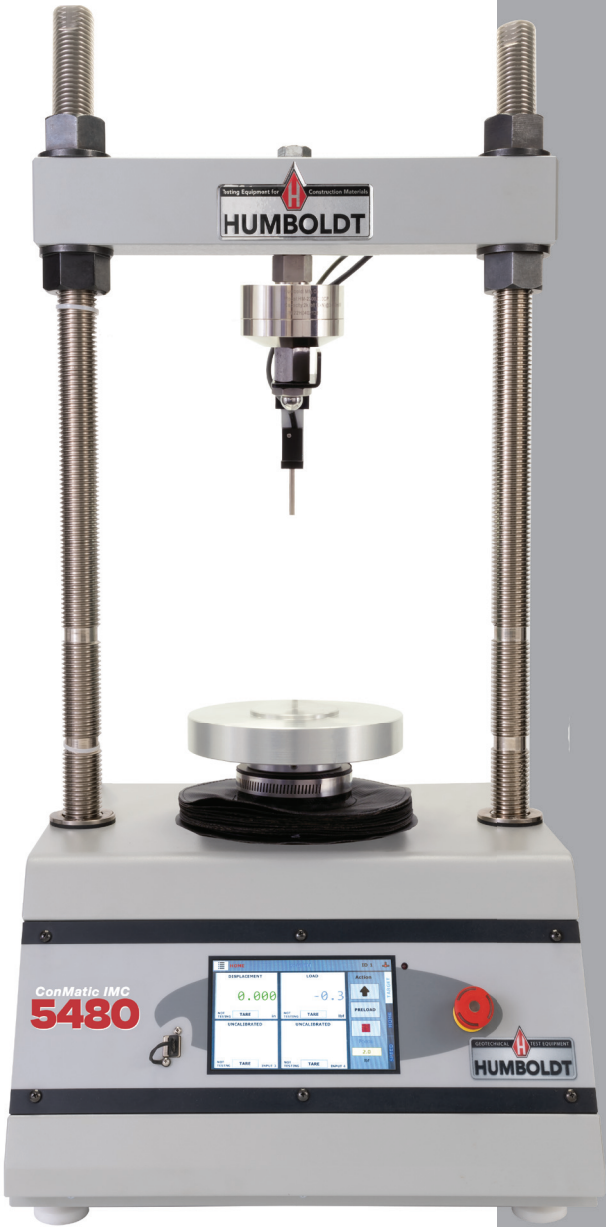

Test Setup

Test Setup

To begin a new test, Click on the Menu icon in the top left corner of the screen (1). When you click on this button, you will see a drop-down menu appear, see below. Click on NEW TEST (1).

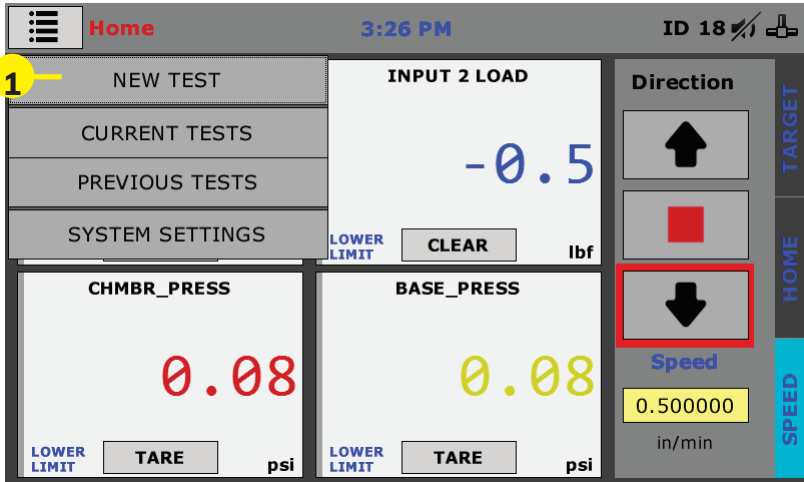

Consolidation

Test Setup Wizard – Select Test Type

Clicking on NEW TEST (1) above brings up the Test Setup Wizard. On the first screen of the Wizard, you can select the type of test you want to perform — click on Consolidation and then click on the arrow button in the bottom right-hand corner (3) to continue.



Test Setup Wizard – Sensor Input Selection

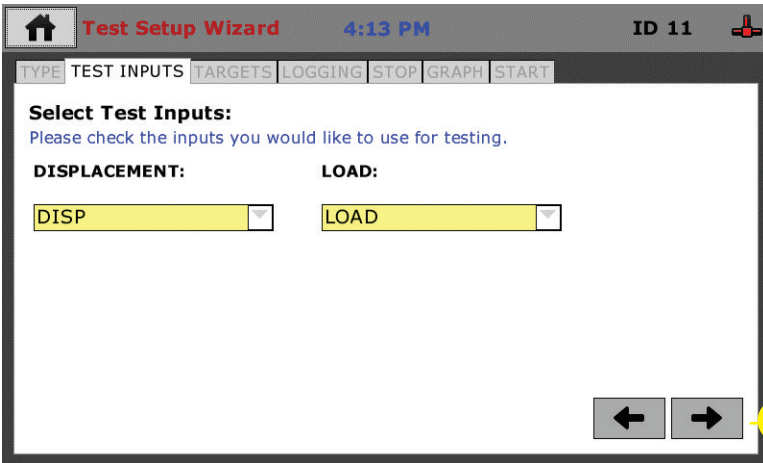

Verify that the channel inputs match the connected sensors.

When you click on the Right Arrow in the lower, right-hand corner of the screen (3) Load window will appear. Verify that the desired load sequence is displayed in the tabulation window. If it needs to be modified there are several options (shown below) that allow you to modify or completely change the loading sequence.

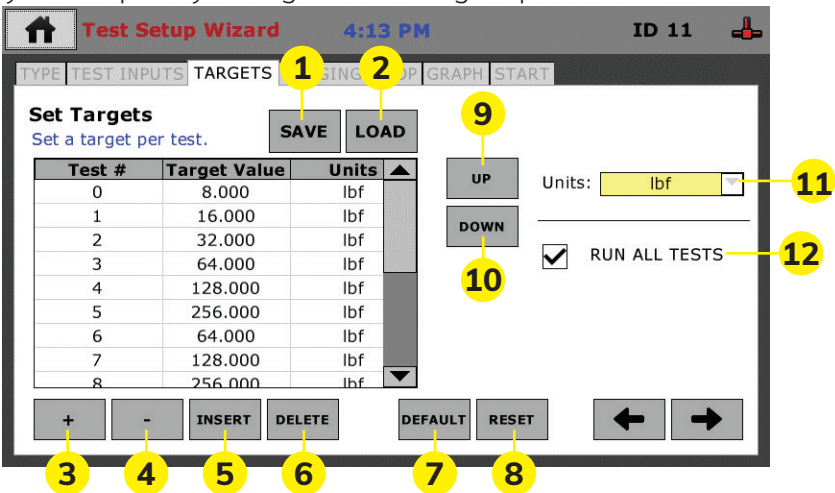

(1)SAVE: This will save the current load sequence to memory for future recall. This is useful if multiple tests are using the same load sequence.

(2)LOAD: This will bring up a menu showing all the previously saved load sequences. From here you can select the desired load sequence for the test.

(3)+: Selecting this button will add a new load immediately following the currently selected sequence. The user can click on the blank Target Value box to enter the desired load value for that specific load.

(4)-: Selecting this box will remove the highlighted load shown in the tabulation window. To highlight a specific load, select the desired load in the load sequence window. Once selected, it will be highlighted in blue.

(5)Insert: Selecting this button will insert a new load into the load sequence. To use this feature correctly the user must select the load immediately preceding where the new load is to be inserted on the tabulation table.

(6)Delete: This will remove the selected load from the sequence. To use this feature. Select the desired load to be removed from the sequence. When the selected box is highlighted in a blue background press the Delete button to remove that specific load from the sequence.

(7)Default: Selecting this will load the default load sequence found in ASTM D2435.

(8)Reset: Selecting this button will reset the load sequence to the previously saved sequence from the last test.

(9)Up: Pressing this button will move the active sequence box up. Once at the desired load, it can be modified or removed as needed.

(10)Down: Pressing this button will move the active sequence box down.

(11)Units: Choose the desired units for the load to be applied during the test.

(12)Run all Tests: Checking this box will cause the test to run all loads within the sequence regardless of any previous loads having been run previously during the test.

Test Setup Wizard – Select Logging Values

From here select the desired logging intervals for your test. The test will default to the ASTM D2435 standard. If the displayed values in the logging table match the desired logging interval press the right arrow in the lower right corner to advance to the stop conditions. If you wish to change the logging interval press the Logging Values button.

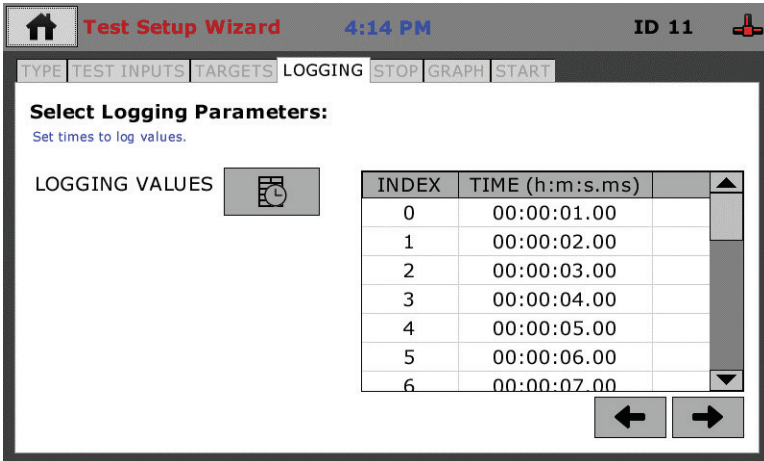

For those who want to use different parameters, you can either click on Use Default **(1)** and change the values to suit your application, or, click on Clear Table **(2)** and fill in the blank table with your values. Once you are satisfied with the completed table, click on the Select button **(3)** to use the Table. Once Select or Cancel are pressed, the window will automatically close.

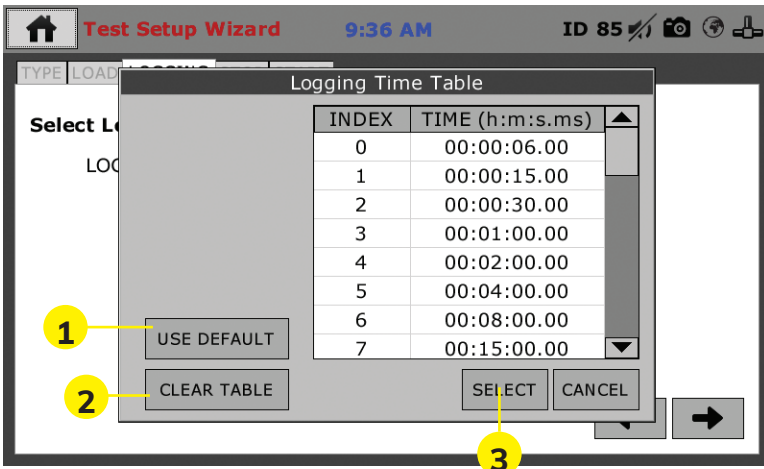

Use Default (1): This will automatically load the ASTM standard logging interval for a consolidation test.

Clear Table (2): This will remove all the time intervals currently loaded for the test. It will be necessary to manually enter the desired values for each time interval by selecting the desired box in the Time column and entering the desired time.

Select (3): This will load the displayed timetable into the test.

Cancel (4): This will close the Logging Timetable window and revert to the original values shown in the previous window.

Test Setup Wizard – Select Stop Parameters

Next you need to select the Stop Parameters for the test. To choose the Stop Value Parameter, Click on the yellow field **(1)** and select a time period from the pop up window that appears.

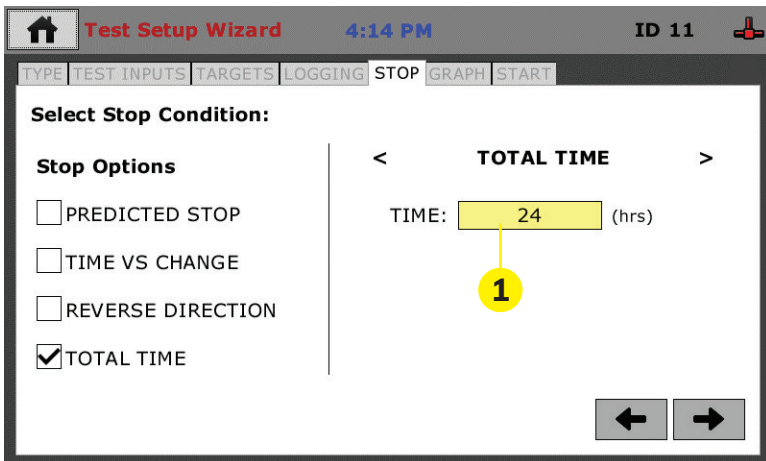

Total Time: Checking this box will allow the user to apply a specific amount of time for the test duration. By pressing the yellow box under Total Time the test duration (in hours) can be selected.

Selecting the right or left arrow will allow the user to cycle through all the stop conditions to review what the setting parameters were set to during previous tests. If the appropriate box is checked for that parameter under Stop Options, then that stop condition will be applied to the test.

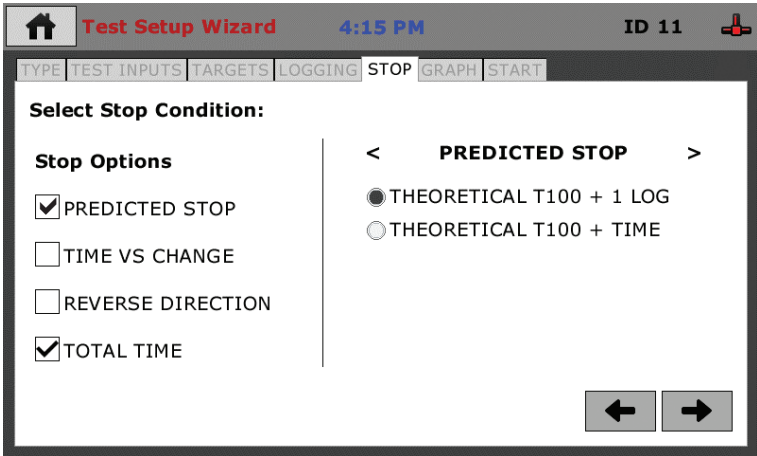

Selecting the Predicted Stop box will allow the user to set either T100+ 1 Log, or T100+Time as a stop condition for each load sequence.

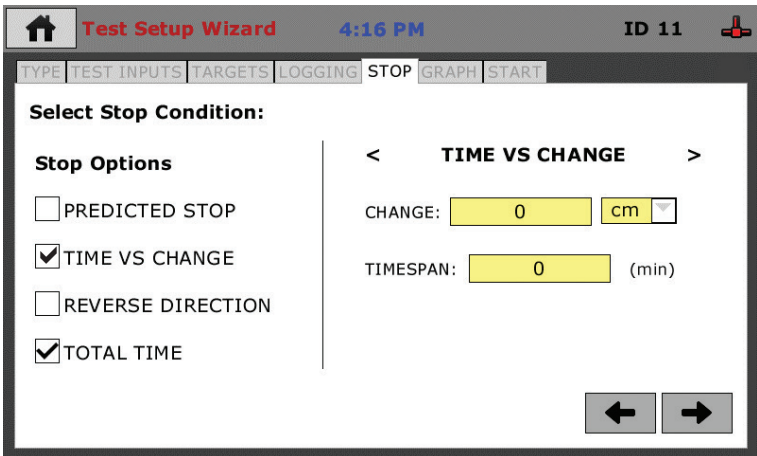

Selecting the Time vs. Change box will cause the test to advance to the next load sequence if the HM-5480 does not detect at least the amount of movement in the sample over a specified amount of time. Both the amount of movement and the timespan are defined by the user. These values can be modified by selecting each of the three yellow boxes to define the user's desired values.

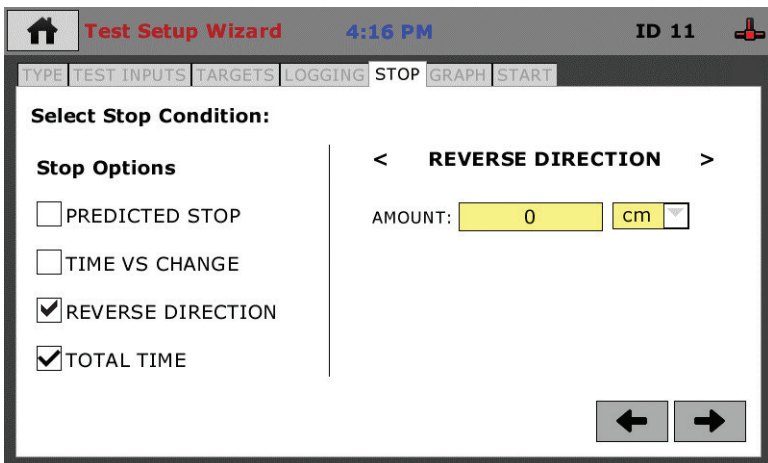

Checking the Reverse Direction box will allow the test to advance to the next load sequence if the sample starts to swell. The amount of swell required for the test to advance is determined by the user by entering the desired values in the yellow boxes.

Graph Tab

Select the desired graphing options for the test.

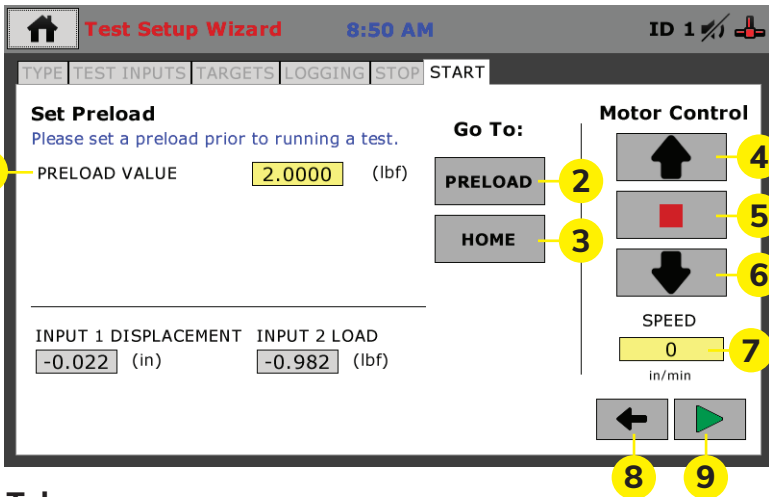

Start Tab

(1)Preload Value: Allows user to select the preload value for the test.

Note: this value is also applied to the Main Screen under the Target tab (page 30). If preload is selected on the Main Screen, it will apply a preload that has been selected from this window.

(2)Preload Button: Selecting this button will cause the HM-5480 to move to the selected preload value.

(3)Home Button: Selecting this button will cause the platen to move to the home position.

(4)Up: Will cause the platen to move up.

(5)Stop: Will stop all movement of the platen.

(6)Down: Will cause the platen to move down.

(7)Speed: Determines the rate of platen movement (either up or down) if the up or down buttons are pressed.

(8)Go Back (Left arrow key): Will revert to the previous test setup window.

(9)Start: Will open a pop-up window for naming the test.

Once the preload has been selected and applied, press the Green Arrow at the bottom right-hand corner of the screen (9). You will then see the screen below.



In the Value Field, create a name for your test (1). Press the check mark button (2) to save your test name. Once the test has been named and the check mark button has been pressed the test will initiate.

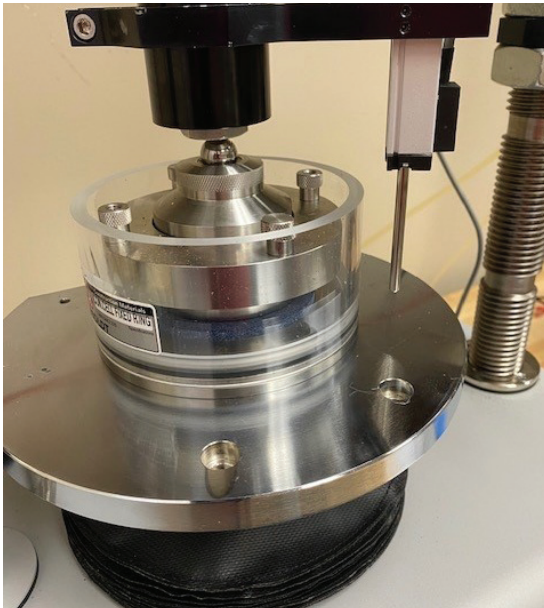

Once completed, press the Green Arrow at the bottom right-hand corner of the screen (4) and you will be taken to the following screen and your test will begin.

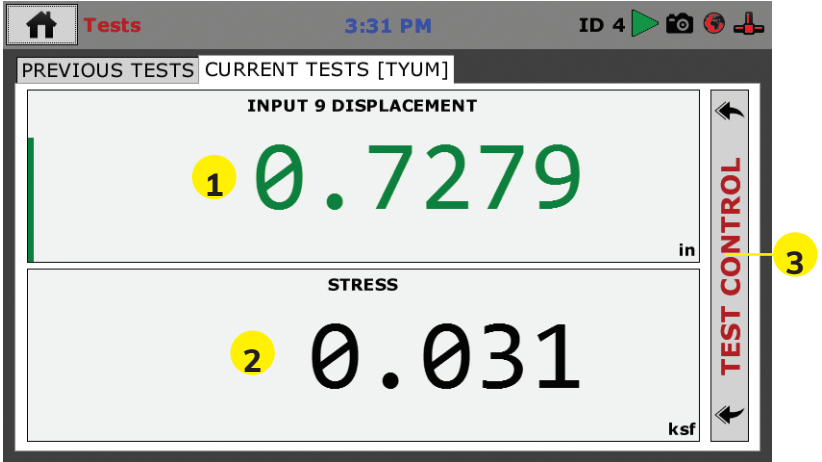

You can monitor your test from this window, which allows you to view the Displacement (1) and the Stress (2), or for additional information, click on the Test Control bar on the right of the window (3), which will reveal the additional panel shown below.

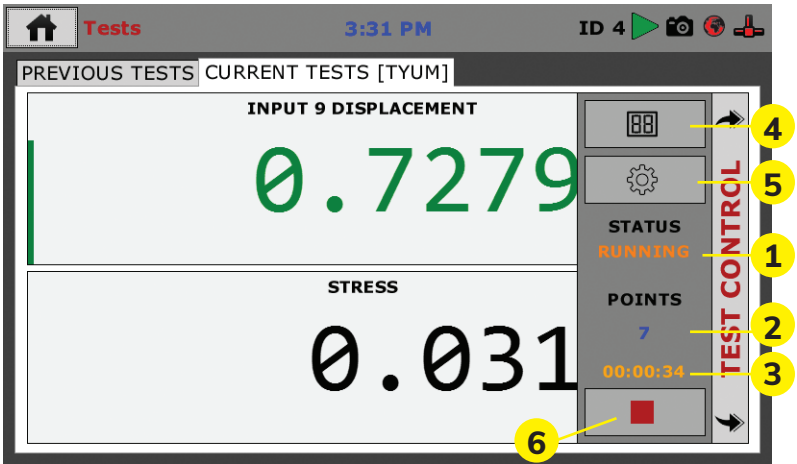

From this new panel you are given the Current Status of your test, in this case, Running (1). You can also see the number of points currently read (2) and the current duration of the test (3).

In addition, by clicking on the Test View button (4) you can toggle through three different views of the current test. These views are:

Selection View

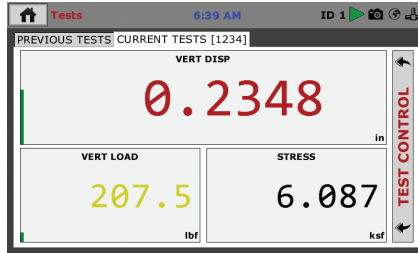

Graph View

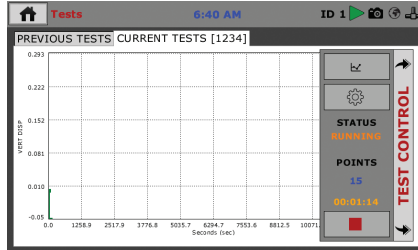

Tabulation View

Tabulation View displays a table of test data. The table has columns for TIME, INPUT 1, INPUT 2, INPUT 3, and INPUT 4. The data points are as follows:

TIME	INPUT 1	INPUT 2	INPUT 3	INPUT 4
0	00:00:00	-	-	0.0000 0.0
1	00:00:05	-	-	-0.0629 205.0
2	00:00:10	-	-	-0.0629 202.4
3	00:00:15	-	-	-0.0629 202.3
6	00:00:30	-	-	-0.0630 206.6
10	00:00:50	-	-	-0.0630 204.3

The interface includes a 'TEST CONTROL' sidebar on the right with buttons for STATUS, POINTS, and a red stop button.

By clicking on the Test selection button (5) brings up the screen below. Here you can toggle between the Previous Tests tab (1), which shows previous test data and the Current Tests tab (2).

The Test selection dialog box is shown. It has two tabs: 'PREVIOUS TESTS' (1) and 'CURRENT TESTS [1234]' (2). The 'CURRENT TESTS' tab is active, showing a list of available tests with '1234' selected. Below the list are 'Select' and 'Cancel' buttons. The dialog is overlaid on the main test interface, which shows 'INPUT' and 'TEST CONTROL' elements.

By clicking on the button with the red box (6) stops the current test.

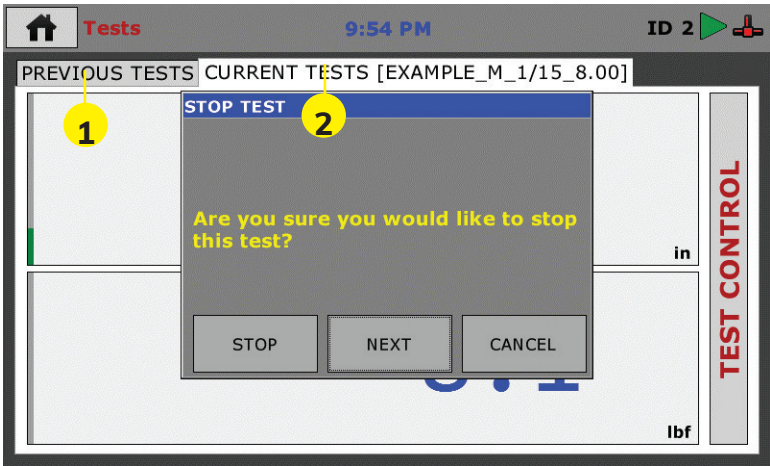

Selecting STOP will terminate the test.

Selecting NEXT will advance the test to the next load sequence.

Selecting CANCEL will close the window and continue the test at the current load sequence.

CRS (Constant Rate of Strain) Test Setup Wizard

1. Select CRS Test button
2. Select the NEXT button on the lower right corner of the touch screen (arrow pointing right).

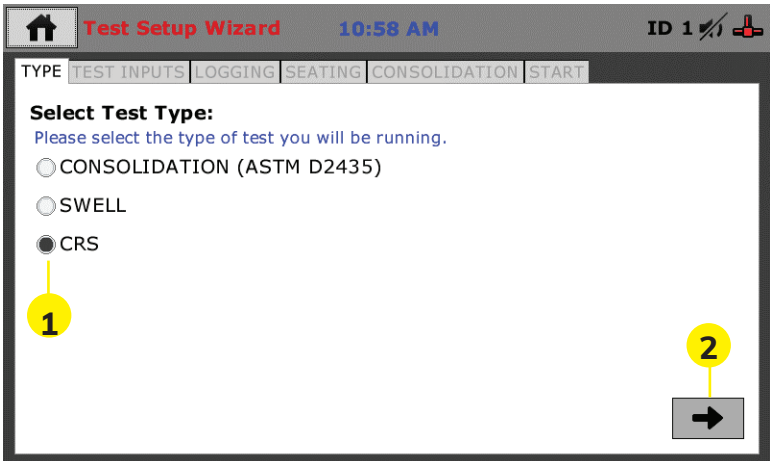

Test Input Tab

Test Setup Wizard 11:00 AM ID 1

TYPE TEST INPUTS LOGGING SEATING CONSOLIDATION START

Select Test Inputs:
Please check the inputs you would like to use for testing.

DISPLACEMENT: INPUT 1 DISPLACEMENT

LOAD: INPUT 2 LOAD

CHAMBER PRESSURE: INPUT 3 PRESSURE

BASE PRESSURE: INPUT 4 PRESSURE

← →

1. Verify that the sensor inputs are correct for each of the channels. For a CRS test, all four sensor inputs are required. The Typical breakdown of the sensors is as follows:
 - a. Channel 1 – Displacement
 - b. Channel 2 – Load
 - c. Channel 3 – Chamber Pressure
 - d. Channel 4 – Base Pressure

The sensor types should match the label for each as listed above each yellow box.

2. Select the NEXT button on the lower right corner of the touch screen (arrow pointing right).

Logging Tab

Test Setup Wizard 11:04 AM ID 1

TYPE TEST INPUTS LOGGING SEATING CONSOLIDATION START

Select Logging Parameters:
Set times to log values.

LOGGING VALUES

INDEX	TIME (h:m:s)
0	00:00:06
1	00:00:15
2	00:00:30
3	00:01:00
4	00:02:00
5	00:04:00
6	00:08:00

← →

1. Ensure that the logging intervals are correct.
 - a. Note: the previous chapter shows how you can modify the logging values by selecting the LOGGING VALUES button.
2. Once the logging values are as desired, press the NEXT (right hand arrow) button.

Seating Tab

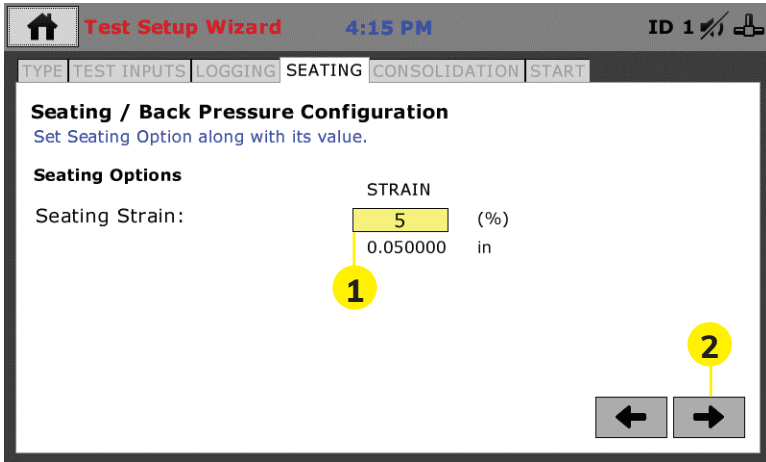

This system is designed to run the seating strain only. The option for setting a seating load has not been incorporated into the test setup yet.

1. Select the desired strain percentage value for setting the seating load. Please note the actual strain that will be applied to the sample. This value is based upon what dimensions are entered for the sample.
2. Select the NEXT button on the lower right corner of the touch screen (arrow pointing right).

NOTE: The strain value will be maintained throughout the saturation phase of the test.

Consolidation Tab

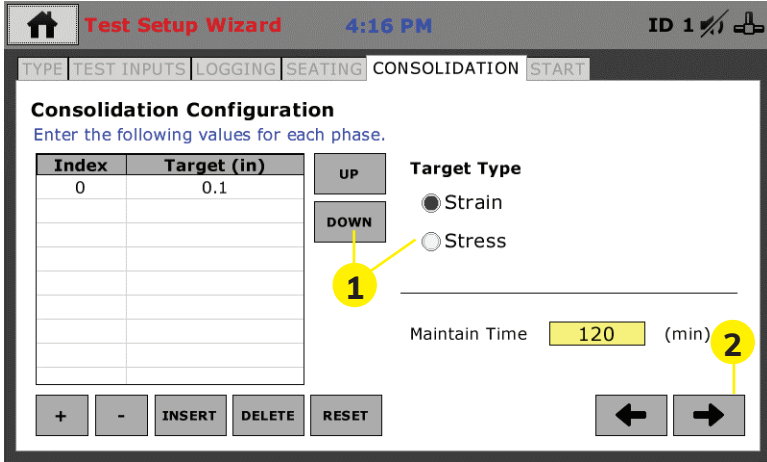

1. The HM-5480 allows for the input of multiple strain or stress values. This is similar to the standard one-dimensional consolidation test allowing for follow-on loads that are lower than the initial target load to measure rebound.
 - a. UP/DOWN Buttons: This will move the selection point to the desired index line. This is used when a target value needs to be modified.
 - b. Target Type: Stress/Strain: Used for determining which consolidation control method is to be used.
2. Select the NEXT button on the lower right corner of the touch screen (arrow pointing right).

Start Tab

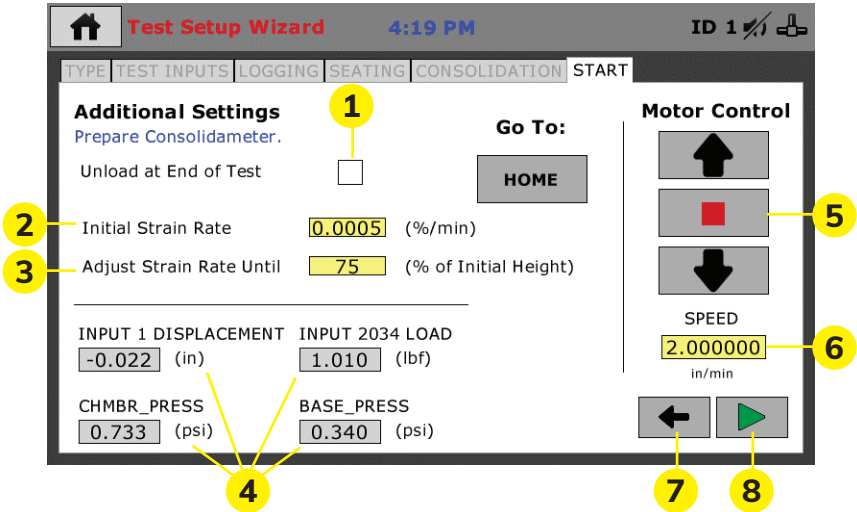

Additional Settings:

1. Unload at End of Test: When this box is selected the platen will retract to its lowest position at the completion of the test automatically.
2. Initial Strain Rate: This will be the value entered by the operator for the strain rate as a percent per minute. This percentage is based on the initial thickness of the sample prior to starting consolidation.
3. Adjust Strain Rate Until: This selection allows the user to determine when the strain rate during consolidation is no longer managed by the pore pressure to chamber pressure ratio.
5. Motor Control: The three buttons allow for the raising, lowering, or stopping the gap between the sample piston assembly and the load cell.
6. Speed: The speed can be manually determined by selecting the Speed Box and entering the speed of the platen. NOTE: during a test this speed will automatically be calculated.
7. Previous Screen: Selecting this button will return the user to the Consolidation configuration tab.
8. Start Test: The button showing the green triangle is the start test button. Selecting this will open a pop-up window for starting the test.

Start:

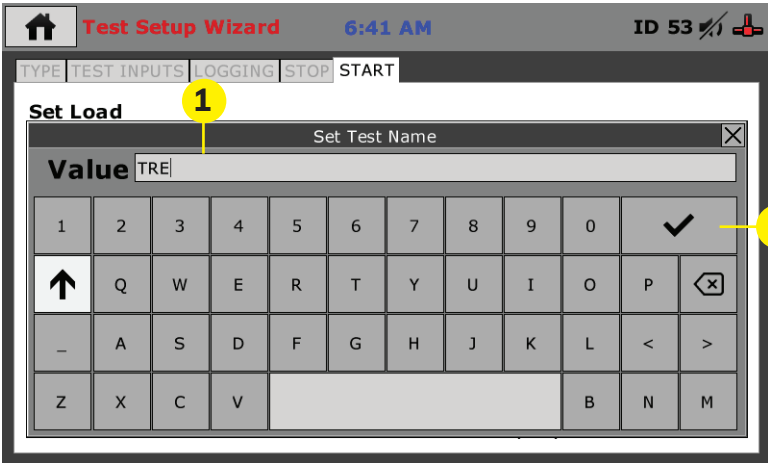

1. Enter the name of the test
2. Select the check mark button to start the test.
2. At this point you will need to manually increase the pore and cell pressure until saturation has been verified as per ASTM D4186.
3. Once saturation has occurred select the Test Control button and press the Next icon button.

Swell Test Test Setup Wizard

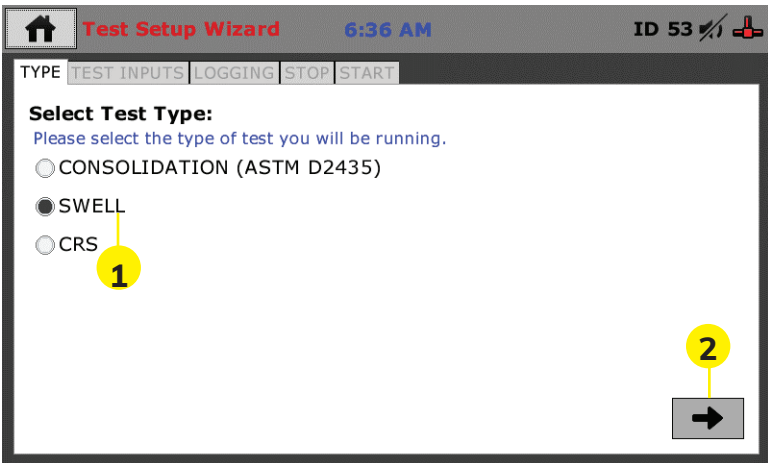

1. Select Swell Test button
2. Select the NEXT button on the lower right corner of the touch screen (arrow pointing right).

Test

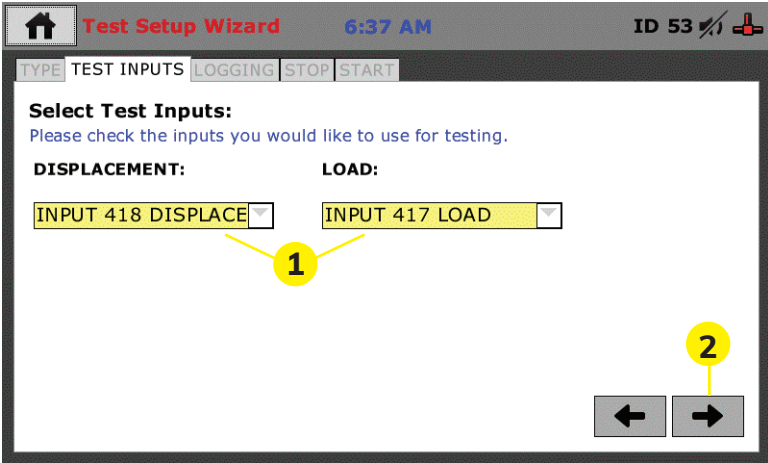

1. Verify the sensor inputs are correct for Displacement and Load.
2. Select the NEXT button on the lower right corner of the touch screen (arrow pointing right).

Logging Tab

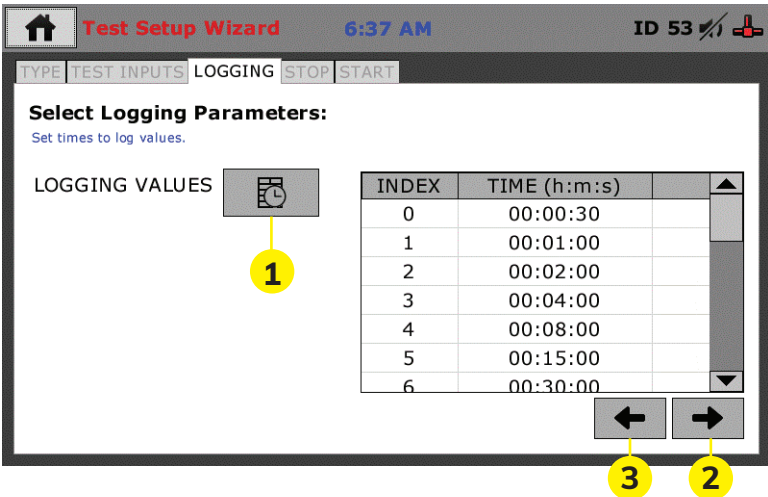

1. Logging Values Button: Provides different logging value options for recording data points during test. Please refer to next illustration for details.
2. Advance to Next button (right arrow key): Moves to the Stop Conditions tab
3. Go back button: (left arrow key): return to the Test Inputs tab.

Logging Value Pop-Up Window

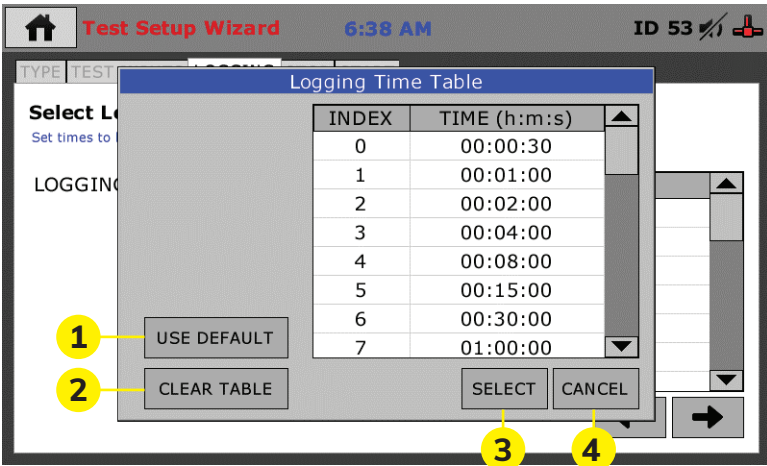

Logging Values Button: Provides different logging value options for recording data points during test.

1. Use Default: This will automatically load in a preset table loaded in the machine's memory.
2. Clear table: This will delete the default logging table to allow a user defined logging interval. Doing this allows the user to define the time intervals for logging the data points. To do this, select the time value to edit. It will highlight the selected cell in blue and allow the user to enter the desired time value.
3. Select: When selected, this button accepts the entered logging intervals (either user defined or default)
4. Cancel: Will close the logging time interval table without saving any inputs made by the user.

Stop Tab

Test Setup Wizard 6:39 AM ID 53

TYPE TEST INPUTS LOGGING STOP START

Select Stop Condition:
Please choose how you would like the test to stop.

Stop Options

TOTAL TIME TIME: 24 (hrs)

TOTAL TIME:

← →

1. Total Time: Enter the total test time desired. NOTE: The time will begin when the test is ready to start the inundated swell portion of the test.
2. Select the NEXT button on the lower right corner of the touch screen (arrow pointing right).

Start Tab

Test Setup Wizard 6:41 AM ID 53

TYPE TEST INPUTS LOGGING STOP START

Set Load Set Test Name

Value TRE

1	2	3	4	5	6	7	8	9	0	✓	
↑	Q	W	E	R	T	Y	U	I	O	P	✕
_	A	S	D	F	G	H	J	K	L	<	>
Z	X	C	V						B	N	M

Set Load:

1. Choose a name for the test
2. Then select the check box.

From here the test will automatically begin applying the starting load

HM-5480.3F Specifications

The HM-5480.3F ConMatic IMC is a fully automated, incremental motor controlled consolidation machine that performs incremental consolidation and one-dimensional swell tests. The ConMatic IMC allows consolidation, Constant Rate of Strain, and Volume Swell tests to be run automatically, freeing up technicians for other tasks effectively saving time and manpower while increasing lab profitability. One ConMatic automated system can replace the production of several manual machines—running incremental consolidation tests according to ASTM D2435 Method B, where successive load increments are applied after 100% primary consolidation.

Once a sample has been placed onto the test platform and the test conditions set, the ConMatic IMC performs all consolidation tests, including moving to the next stress level, without operator assistance. The system automatically moves through the different test parameters specified by the user with incremental consolidation tests that are typically completed within 24 to 48 hours. The HM-5480 can be used in conjunction with the Humboldt NEXT software where test data can be exported from the HM-5480 into the NEXT Consolidation module for more comprehensive test analysis and the production of detailed test reports for the customer. The Humboldt NEXT software provides the following:

- Live tests and live graphing capabilities (real-time)
- Complete test reporting including all calculations and graphs required for testing
- Review and exporting of tests using Microsoft Excel
- Smart Test Function: automatically picks up where it left off if the test was not finished due to unexpected events within your computer

The unique design of the ConMatic IMC system enables the user to connect multiple Conmatic IMC units to a single computer to facilitate downloading and processing test data from multiple machines simultaneously.

Specifications:	
Sample size	up to 4" (100mm)
Maximum load	2200lbf (10kN)
Clearance, vertical	8.25" (210mm)
Clearance, horizontal	7.75" (197mm)
Maximum piston travel	0.5" (12.7mm)
Dimensions (L x W x H)	12" x 12" x 30" (305 x 305 x 762mm)

ConMatic IPC includes:	
(1) S-type load cell 2,000 lbs (10kN) with 0.75" adapter	HM-2300.20
(1) Linear strain transducer, 1.0" (25mm)	HM-2310.10
(1) Linear strain transducer Bracket	M-2310BR
(1) NEXT consolidation software module	HM-5100SW
(1) Ball 0.625" 440 stainless steel	HM-001076

Controller Specifications:	
Display (Resistive Touch)	7" (178mm) VGA (480 x 800)
Real-time test data	Graphic and tabulation
Processor	Dual 32-bit ARM
RAM	64MB
Memory, non-volatile	4GB
Analog to digital converter	24 bit
Data acquisition	4 Channels
Logging speed	up to 50 readings per second
Multi-test storage	1000
Points per test	3000
USB port (front)	export data, import/export calibration data, WiFi
USB port (back)	provides external power for wireless access point
Ethernet connection	for network connectivity
Emergency stop	Large button
24-bit differential analog to digital converter	4
Ambient temperature sensor	1
Limit switches	2
Firmware Update	Ethernet or flash drive

Additional Items needed for setup:

Consolidation Installation and Spare Parts Kit

Installation and spare parts kit provides tubing, fasteners and tools to complete an installation of pneumatic consolidation equipment.

Consolidation Installation and Spare Parts Kit HM-4168

ConMatic IPC System Requirements:

AC Supply: 110/220 VAC 50/60 Hz 5 Amp

Air Supply: Clean and dry
(air filter, water trap),
minimum: 100 psi (700kpa)
continuous air supply,
10CFM (0.3 m³/min)

General Warnings

Safety Warnings

Operators should take care to operate this machine under maximum load restrictions. The machine is programmed at the factory to provide safety shutdown if the upper or lower maximum travel is exceeded, as well as if the upper instrument calibration is exceeded.

Electrical Warnings

Typically, there is no reason for the operator to open the machine. However, if the customer's engineers attempt to change settings to the circuit board connected to the back panel, the machine must first be unplugged. Unplugging the internal connection to the back panel circuit board while the machine is under power will result in permanent damage to the circuit board.

Important Notice

The information contained herein is supplied without representation or warranty of any kind. Humboldt Mfg. Co. therefore assumes no responsibility and shall have no liability, consequential or otherwise, of any kind arising from the use of the described equipment contained in this manual.

Updated Products

The manufacturer reserves the right to change or modify product design or construction without prior notice and without incurring any obligation to make such changes and modifications on products previously or subsequently sold.

Fitness for Application

The manufacturer makes no recommendations or claims regarding fitness for applications other than the specific tests as defined in this User Guide.

Unpacking

Initial inspection should include checking for physical damage during shipping and obvious external damage to the product. Package contents are defined by your packing list. Each Loader is configured according to customer specifications. In your inspection, make certain that the contents of your shipment match the documentation provided by your packing list.

Place unit on a flat, smooth surface and use leveling feet (supplied) and a bubble level to ensure that the unit is level side-to-side and back-to-front.

Warranty

Humboldt Mfg. Co. warrants its products to be free from defects in material or workmanship. The exclusive remedy for this warranty is Humboldt Mfg. Co., factory replacement of any part or parts of such product, for the warranty of this product please refer to Humboldt Mfg. Co. catalog on Terms and Conditions of Sale. The purchaser is responsible for the transportation charges. Humboldt Mfg. Co. shall not be responsible under this warranty if the goods have been improperly maintained, installed, operated or the goods have been altered or modified so as to adversely affect the operation, use performance or durability or so as to change their intended use. The Humboldt Mfg. Co. liability under the warranty contained in this clause is limited to the repair or replacement of defective goods and making good, defective workmanship.

Manufacturer's Rights and Responsibilities Software Copyright

COPYRIGHT NOTICE

©2016 HUMBOLDT Mfg. Co. All Rights Reserved. This manual or parts thereof may not be reproduced in any form without the expressed written permission of HUMBOLDT Mfg. Co.
UNPUBLISHED LICENSED PROPRIETARY WORK
©2016 HUMBOLDT Mfg. Co.

The programmable, read-only memory, integrated circuit package contained in this equipment and covered with a copyright notice label contains proprietary and confidential software, which is the sole property of HUMBOLDT MFG. CO. It is licensed for use by the original purchaser of this equipment for a period of 99 years. Transfer of the license can be obtained by a request, in writing, from HUMBOLDT MFG. CO.

With the exception of HUMBOLDT Authorized Service Facilities, you may not copy, alter, de-compile, or reverse assemble the software in any fashion except as instructed in this manual. US copyright laws, trademark laws, and trade secrets protect the materials. Any person(s) and /or organizations that attempt or accomplish the above violation or knowingly aid or abet the violation by supplying equipment or technology will be subject to civil damages and criminal prosecution. With the exception of HUMBOLDT Authorized Service Facilities, you may not copy, alter, de-compile, or reverse assemble the software in any fashion except as instructed in this manual. U.S. copyright laws, trademark laws, and trade secrets protect the materials.

Any person(s) and /or organizations that attempt or accomplish the above violation or knowingly aid or abet the violation by supplying equipment or technology will be subject to civil damages and criminal prosecution.

Humboldt Mfg. Co.
875 Tollgate Road
Elgin, Illinois 60123 U.S.A.

U.S.A. Toll Free: 1.800.544.7220
Voice: 1.708.468.6300
Fax: 1.708.456.0137
Email: hmc@humboldtmfg.com

