

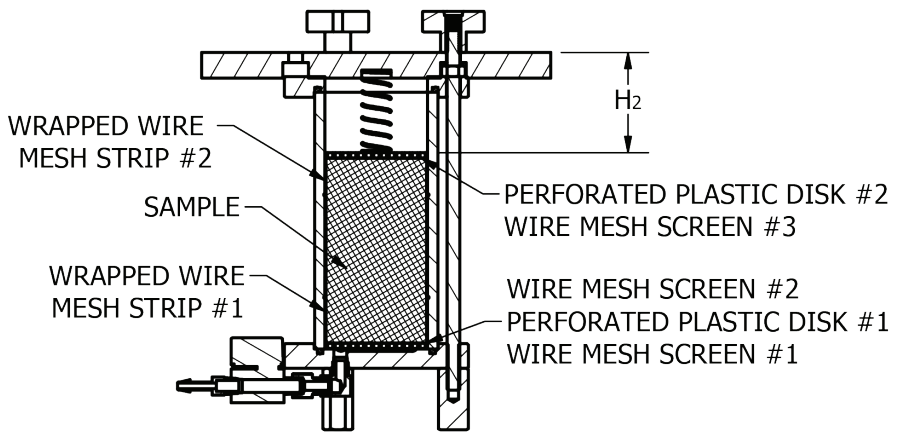

Universal Top Plate  
with Measuring Slots

## Directions for use:

1. Remove the top plate from the permeameter assembly.
2. Insert a circular wire mesh screen on the bottom of the cylinder followed by a perforated plastic disk, and then a second wire mesh screen.
3. Place the wire mesh screen and perforated plastic disk to be used for the top of the sample on top of the other screens and perforated plastic disk. There should now be a total of three circular wire mesh screens and two perforated disks stacked together.
4. Place the slotted universal top plate onto the assembly and fasten it using the three knobs.
5. Measure H1 from the top of the slotted top plate, through the slots, to the top of the screens and perforated disks.
6. Remove the slotted universal top plate, wire mesh screen, and perforated disk for the top of the sample.
7. Prepare the sample per ASTM D2434 with the wire mesh strips wrapped inside the cylinder to cover the ports for the manometers.
8. Place the circular wire mesh screen on top of the sample followed by the perforated disk that was removed in step 6.
9. Remove the spring from the top plate used for the test and install it in the slotted top plate.
10. Place the slotted universal top plate on the assembly and fasten it using the three knobs.
11. Measure H2 from the top of the slotted top plate, through the slots, to the top of the perforated plastic disk.
12. Before starting the test, remove the slotted top plate and spring and place the top plate for the test with the spring on the assembly.

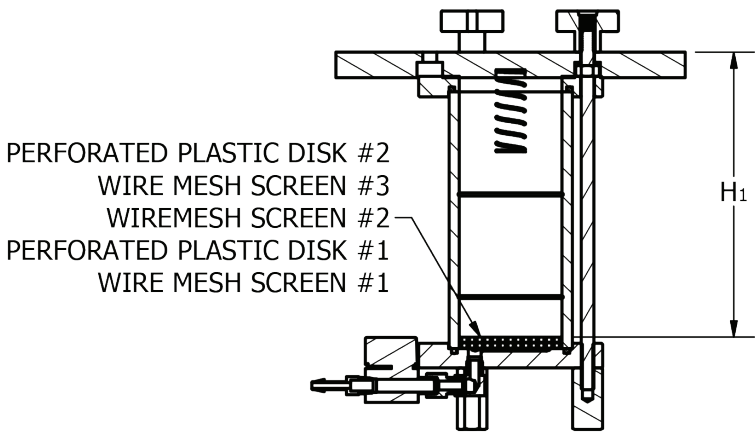
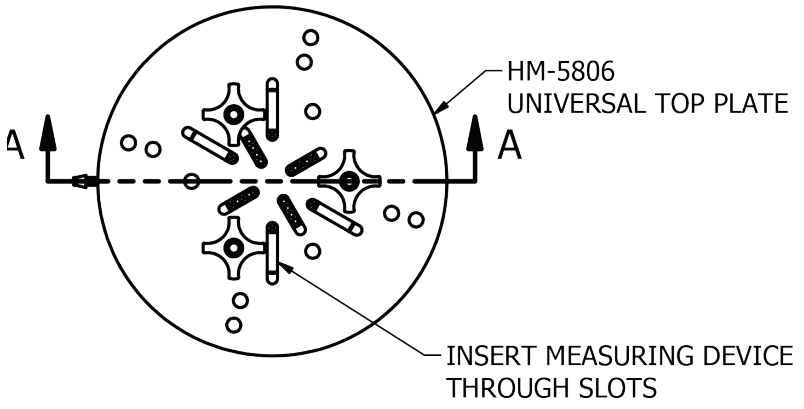

## Warranty

Humboldt Mfg. Co. warrants its products to be free from defects in material or workmanship. The exclusive remedy for this warranty is Humboldt Mfg. Co., factory replacement of any part or parts of such product, for the warranty of this product please refer to Humboldt Mfg. Co. catalog on Terms and Conditions of Sale. The purchaser is responsible for the transportation charges. Humboldt Mfg. Co. shall not be responsible under this warranty if the goods have been improperly maintained, installed, operated or the goods have been altered or modified so as to adversely affect the operation, use performance or durability or so as to change their intended use. The Humboldt Mfg. Co. liability under the warranty contained in this clause is limited to the repair or replacement of defective goods and making good, defective workmanship.

### **Humboldt Mfg. Co.**

875 Tollgate Road  
Elgin, Illinois 60123 U.S.A.

U.S.A. Toll Free: 1.800.544.7220

Voice: 1.708.456.6300

Fax: 1.708.456.0137

Email: [hmc@humboldtmfg.com](mailto:hmc@humboldtmfg.com)

Testing Equipment for



Construction Materials

# HUMBOLDT

[www.humboldtmfg.com](http://www.humboldtmfg.com)